



**SECTION-I**  
**SHORT NOTICE INVITING E-TENDER**  
**(DOMESTIC COMPETITIVE BIDDING)**  
**(SINGLE STAGE TWO ENVELOPE BIDDING)**

DNIT No: **DGM/KMP/24-25/02** dated: **12.06.2024**

NIT No : **DGM/KMP/24-25/02** dated: **12.06.2024**

FUNDING: PWD (DWS), TRIPURA

- 1.0 Deputy General Manager, Electrical Division, Kamalpur, TSECL, Kamalpur invites the tender on behalf of TSECL for the work of “**Extension of HT/LT line & installation of 1X5X25 KVA Transformers for improvement of Voltage at different SBDTW schemes ( 1. Srirampur VC near house of Chandra Singh Debbarma, 2. Mayachari GP near house of Shibananada Parshi , 3. Debichara G.P near house of Krishnakanta Sinhga 4. Chulubari G.P 4. Near house of Aunturam Gour 5. Near house of Jagannath Gour Chulubari G.P, 6. Mahabir Tea garden no -2 AWC, 7. Ramjatan Koli Mahabir G.P, 8. Debichara G.P near House Birendra Malakar 9. Near house of Ranjit Roy Debichara G.P, 10. Malirai Para at Ashupurna Roaja Para) under ED Kamalpur of TSECL under Dhalai District of Tripura**” through **electronic tendering (e-tendering)** from eligible and resourceful contractors/firms having sufficient credential and financial capability for execution of works of similar nature on **Partial Turn-key basis**.

**Estimated Cost: Rs.16, 81,887.00**

**Earnest Money: Rs 33,638.00**

**Tender Fee: Rs. 1,000.00**

- 2.0 This NIT for the above work shall be appeared in local Newspapers, this shall also be available on Tripura State Electricity Corporation Limited website at <http://www.tsecl.in> from 13.06.2024 **The complete Bidding Documents including tender drawings and technical specifications shall be available at Government e-procurement portal <http://tripuratenders.gov.in> from 13.06.2024.** Interested bidders can download the Bidding Documents and commence preparation of bids to gain time.
- 3.0 Eligible bidders shall participate in tender online through the government e-procurement portal at <http://tripuratenders.gov.in>. Tender shall be uploaded/submitted in a two-bid system:
- (a) Bid Envelop-I (Technical bid)
  - (b) Bid Envelop-II (Financial bid)
- 4.0 Bidders willing to take part in the process of e-tendering are required to obtain a valid Class 2/Class 3 **Digital Signature certificate (DSC)**, from any of the of the certifying authorities, enlisted by Controller of Certifying Authorities (CCA) at <http://cca.gov.in>. After obtaining the Class 2/3 Digital Signature Certificate (DSC) from the approved CA, Bidders shall Enroll themselves in the Tripura Government e-procurement web site at '<http://tripuratenders.gov.in>' and obtain User ID and Password for the purpose of bidding.

- 5.0 **Critical Dates:**



1.	Completion period for the work:	1(one) Months.
2.	Period of downloading of Bidding Documents at tripuratenders.gov.in:	From: 14.06.2024 To: 21.06.2024
3.	Period of Seeking clarification:	From: 14.06.2024 To: 15.06.2024
4.	Time and date of Pre-Bid Meeting:	15.06.2024
5.	Place of Pre-Bid Meeting:	Deputy General Manager, Electrical Division Kamalpur, TSECL , Dhalai Tripura Pin: 799285. Mobile : 6033131862.
6.	<b>Deadline for online Bidding:</b>	<b>21.06.2024</b>
7.	Time and Date of Opening Technical Bid/Bids:	<b>22.06.2024</b>
8.	Time and Date of Opening Price/Financial Bid/Bids :	To be notified after Technical Evaluation
9.	Place of Opening Bids:	Deputy General Manager, Electrical Division Kamalpur, TSECL , Dhalai Tripura Pin: 799285. Mobile : 6033131862.
10.	Bid Validity:	6 (six) Months from the date of Opening of Technical Bid.
11.	Officer inviting Bids (Employer):	Deputy General Manager, Electrical Division Kamalpur, TSECL , Dhalai Tripura Pin: 799285. Mobile : 6033131862.

## 6.0 Scope of Work:

The scope of work under the subject package includes site survey, planning, design, engineering, assembly manufacturing, testing, supply, loading, transportation, unloading, insurance, delivery at site, handling, storage, installation, testing, commissioning and documentation of all items/material required to complete "**Extension of HT/LT line & installation of 1X5X25 KVA Transformers for improvement of Voltage at different SBDTW schemes ( 1. Srirampur VC near house of Chandra Singh Debbarma, 2. Mayachari GP near house of Shibananada Parshi , 3. Debichara G.P near house of Krishnakanta Sinhga 4. Chulubari G.P 4. Near house of Aunturam Gour 5. Near house of Jagannath Gour Chulubari G.P, 6. Mahabir Tea garden no -2 AWC, 7. Ramjatan Koli Mahabir G.P, 8. Debichara G.P near House Birendra Malakar 9. Near house of Ranjit Roy Debichara G.P, 10. Malirai Para at Ashupurna Roaja Para) under ED Kamalpur**" on Partial Turn-Key basis.

The above Scope of work is only indicative. The detailed scope has been described in the SBD and as per schedule of item(s)/BoQ.

**Name of Consignee: - DGM,ED-Kamalpur**

## 7.0 QUALIFYING REQUIREMENTS FOR BIDDERS:

*To be qualified to bid for the package, the bidder shall have to meet the following minimum criteria:*

- 7.1 The bidder must have done construction and commissioning work of 11KV line or above voltage class including Distribution Transformers of minimum 30% quantity of 11 KV line and Distribution Transformers



given in this tender in a single award on turnkey/partial turnkey basis during last 7(seven) years which must be in satisfactory operation for at least 1 (one) year from last date of submission of present bid as per NIT. Performance certificate from reputed Indian Power Utility not below the rank of Executive Engineer / Deputy General Manager / Divisional Engineer or equivalent to be submitted along with technical bid. Experience as Sub contractor will not be considered in this case.

- 7.2 The minimum average annual turnover of the bidder for the last three years shall be not less than 30% of the estimated cost put to tender.
- 7.3 Bids may be submitted by an individual firm (proprietorship entity) with relevant experience or registered partnership firm or companies registered under companies act or joint ventures of registered firms/companies/ proprietorship entity with two constituents only as one of the following.
  - 7.3.1 A single firm of proprietorship entity or registered partnership firms or companies registered under Companies Act, which meets anyone or both the requirements, indicated in para 7.1 above and 7.2(Mandatory).
  - 7.3.2 A joint venture/consortium of two registered firms/companies/ proprietorship entity, wherein each registered firm/company/ proprietorship entity shall meet any one or both the requirements of para 7.1, 7.2. Out of two bidders one bidder must fulfill the requirement of Para 7.1
  - 7.3.3 The figures of average annual turnovers for each registered firm/company/ proprietorship entity shall be added together to determine the bidder's compliance with the minimum average annual turnover requirement for the package as given at para 7.2 above.
- 7.4 In case of joint ventures /consortium, any of the registered firms/companies/ proprietorship entities shall be authorized to incur liabilities and receive instructions for and on behalf of any and all partners of the joint venture/consortium and the entire execution of the contract including receipt of payment shall be done exclusively through him. This authorization shall be evidenced by submitting a registered power of attorney signed by legally authorized signatories of all the partners.
- 7.5 All partners of Joint Venture/consortium shall be liable jointly and individually / severally for the execution of the contract in accordance with the contract terms. A copy of the agreement of joint venture/consortium partners having such provision shall be submitted with the bid.
- 7.6 Notwithstanding anything contained herein above, TSECL reserves the right to assess the "capacity and capability" of the bidder to execute the work.
- 7.7 In addition to qualifying requirement mentioned above, the bidder's offer must include the following documents which to be submitted with technical bid
  - i. Copy of PAN Card and Photo Copy of Goods & Service Tax (GST) registration certificate.
  - ii. Copy of EPF registration certificate & labor license certificate is to be submitted as per rule.
  - iii. Copy Electrical Contractor license and supervisory certificate of competency for requisite parts.
  - iv. Copy of balance sheet of the bidder (audited by Chartered Accountant) with auditor's certificate in support of annual turnover i/c IT Return Certificate for the last 3 (three) years of session 2020-21, 2021-22, & 2022-23
  - v. **Any bidder who has been debarred /black listed by any Central (GOI)/State Govt owned Power Utility, for works of similar type during last 3 years for whatever reasons and thereby shall stand**



**disqualified automatically at the very pre-qualification stage. Therefore, the bidder submitting the tender documents is liable to enclose a “Declaration” to this effect with due certification by “NOTARY” depicting full name & designation. (As per Format, annexed in Bid document).**

- vi. Notwithstanding anything stated above, TSECL reserves the right to assess the Bidder’s capability and capacity to perform the contract satisfactorily, should the circumstances warrant such assessment in the overall interest of TSECL.
- vii. The above stated requirements are minimum and the TSECL reserves the right to request for any additional information and also reserves the right to reject the proposal of any bidder, if in the opinion of the owner, the qualification data is incomplete or the bidder if found not qualified to satisfactorily perform the works.
- viii. Price bid of only those bidders shall be opened who qualify based on the specified qualifying requirements after Scrutiny of details / documents furnished by them and found to be techno- commercial responsive.

The bidder shall furnish documentary evidence in support of the qualifying requirements stipulated above along with their bid. Bid received without such documents shall be summarily rejected.

#### **8.0 Earnest Money Deposit amounting to 2% (Two Percent) of the estimated cost put to tender.**

Tender Fee and EMD are to be paid electronically using the Online Payment Facility provided in the Portal. For online payment of Tender Fee and EMD, please follow the following process-

- After initiating the Bid Submission Process from "My Tender" option, an "Online Payment" page will appear which will display the total Tender Fee & EMD amount.
- On submission of TF & EMD payment option, System will redirect to the SBI Bank MOPS window.
- SBI MOPS will have two options for Net Banking- "SBI"&"Other Banks". Bidder can choose any of the options as desired and can complete the Online Payment process.

The EMD amount shall be refunded to all the bidders including L1 (Selected) bidder in their respective Bank Account, after the Award of Contract (AoC) event is completed in the Tripura e-Procurement Portal, on receipt of Performance Bank Guarantee from the selected bidder.

EMD of the bidder may be forfeited if in any case found to have made in false Declaration or Claims.

#### **9.0 Power of Attorney, if given to authorized signatory for signing the Contract Agreement, shall be made in an INDIA NON-JUDICIAL STAMP OF Rs.100.00 (Rupees one hundred) only.**

- 10.0 On award of work the successful bidder shall have to deposit a **Contract Performance Guarantee (CPG)** equivalent to 10% of the LOA value / Supply order value in the shape of Demand Draft in favour of **“Tripura State Electricity Corporation Limited”** from any schedule Bank guaranteed by Reserve Bank of India, payable at Kamalpur or in the shape of Bank Guarantee from a Public sector / scheduled Indian Bank guaranteed by Reserve Bank of India. The **CPG** within the definition of **clause 36.0 of section –II** of the bid document shall remain valid for actual completion period plus guarantee period against the item as per provision of **clause 14.0 of section-III** of the bid document. Extension of bank guarantee for performance of the contract shall be extended as & when asked by the Engineer in charge to keep the currency of the contract alive. In the event of failure on the part of agency to extend the bank guarantee before expiry of the bank guarantee submitted, the same shall be uncashed without showing the reason thereof.



- 11.0 The acceptance of Price bid (Financial bid) shall be subjected to acceptance of Tender fee.
- 12.0 The Bidding Documents are meant for the exclusive purpose of bidding against this specification and shall not be transferred to any other party or reproduced or used otherwise for any purpose other than for which they are specifically issued.
- 13.0 Downloaded NIT, Bid Document are to be uploaded back and digitally signed as a part of technical bid, and as a proof of acceptance of all terms and conditions in NIT and Bid Document.
- 14.0 **Submission of Bids:**

Bids are to be submitted online through the website, and as, stated in Clause 1.0 and 2.0 and 3.0. All the Bidding documents (SBD, Scan copy of tender fee) uploaded by the TSECL form an integral part of the contract. Bidders are required to upload these bidding documents as asked for in the Bid, through the above website and within the stipulated date and time mentioned in the Tender.

Tenders are to be submitted in two folders at a time for each work, one for Technical Proposal and the other for Financial Proposal. The Bidder shall carefully go through the requirements and prepare the required documents to be uploaded.

In Technical Bid, Bidder shall have to submit the entire requisite document as specified in the SBD (SBD, details payment of tender fee and EMD, all forms/Amendments/Formats/Annexure with supporting documents/certificates, Technical Data Sheet/GTPs and drawings, Test Reports, Financial, Tax related document, machinery & manpower details specified in the Bid Document etc.

In, Financial Bid Bidder shall upload BOQ in the financial Bid.

The bidder shall scan all the documents before uploading and all scanned documents shall be of 100 dpi resolution in Portable Document Format (PDF). The scanned documents shall be uploaded in the designated locations of Technical Bid and Financial Bid, as prompted by the e-Procurement website.

The Bidder needs to fill up their name and rates for all the items and in the designated Cells of the downloaded BOQ for the related work, and upload the same in the designated location of Financial Bid. The documents uploaded are virus scanned and digitally signed using the Digital Signature Certificate (DSC). Bidders shall specially take note of all the addendum/corrigendum related to the tender and upload the latest documents as part of the tender.

#### **Bid Envelop-I (Technical Bid):**

The Technical Bid/Bid Envelop-I should contain scanned copies and/or declarations in the following standardized formats.

#### **A. My Document (Non-Statutory):**

All the below-mentioned documents/certificates are to be uploaded with digital signature in the 'My Document' folder option available after login in the e-procurement portal <http://tripuratenders.gov.in>. Bidders are requested to scan the necessary documents in 100 dpi resolution into PDF. 'My Document' shall be populated prior to real time bidding and during real time bidding, uploaded documents/certificates in the 'My Document' are to be appropriately included (Checked) for incorporation in the Bid.



An indicative organization of 'My Document' folder and the related documents are indicated here under.

Sl.	Folder Name	Documents to be uploaded
1.	Mfg.Lic.	<b>Company Details:</b> I. <b>Registration of the firm/Partnership deed/ Articles of Association joint venture/Consortium.</b>
2.	DNIT Documents	I. Corrigendum, if published
3.	Machinery Details	Machinery & Manpower in possession of the firm:
4.	Tax related document	I. GST Registration certificate II. IT PAN
5.	Financial details	I. Audited Balance Sheets of last five financial years with auditor's certificate regarding annual turnover i/c IT Return Certificate from contracting business in each year.
6.	Misc. document	I. Electrical Contractor License & supervisory certificate II. Valid Labour License III. EPF Registration Certificate IV. Any other important document.

#### **B. Statutory Documents:**

After uploading the above mentioned non-statutory documents/certificates, Bidders shall submit the following, during real time bidding

1. NIT.
2. Bid Document.
3. All annexure/ formats/certificates i/c supporting documents/certificates in support of qualifying requirement other than mentioned in My Document specified in the Bid Document in single PDF.
4. Technical Data Sheet/GTPs, Guarantee/Test report etc. offered by the original manufacturer and drawings specified in the Bid Document

**Note-1:** Failure of submission of any one of the above-mentioned documents shall render the tender to summarily rejection.

**Note-2:** If the company was set up less than three years ago, audited balance sheet for the no of years since inception is to be submitted.

**Note-3:** Bidders are requested to scan the necessary documents/certificates in **100 dpi** resolution into PDF.

#### **Bid Envelop-II (Financial Bid):**

Documents to be submitted in the Financial Bid are:

1. BOQ (Bill of quantity/Price schedule).

**Note:** Bill of Quantity (BOQ) i.e., Price schedule, which is the Rate quoting sheet in MS-excel shall be downloaded, filled up properly and uploaded in the financial bid after digital signing. The Bidder shall always





open the BOQ sheet with Macros Enabled. The Bidder shall quote rates in figures only, for all items in the Bill of Quantity (BOQ).

**15.0 BOQ (Price Schedule) TAMPERING:** The provided BOQ (Price schedule) in the Tender is meant for downloading in the Bidders client machine, for entering the relevant fields meant for rates & bidder's particulars and finally uploading in the Financial Bid. The BOQ Excel Sheet is Macro enabled and working with the Sheet requires the Macro to be allowed/ enabled to run.

Bidders are hereby warned not to tamper the Excel Sheet, make copies and work in a copied Sheet or break through the default Work-Sheet Security. Such BOQs with stated violations will be treated as Tampered BOQs and Bids uploaded with Tampered BOQs will be summarily rejected.

**16.0** Bidders are allowed to bid 24x7 till the time of Bid closing, with option for Re-Submission, wherein only their latest submitted Bid will be considered for evaluation. The e-Procurement website will not allow any Bidder to attempt bidding, after the scheduled date and time.

**17.0** For any clarification related to NIT/Bid Document/e-procurement, bidder(s) are requested to contact:

Deputy General Manager  
Electrical Division Kamalpur  
Tripura State Electricity Corporation Limited

**18.0 Addendum/amendments/corrigendum:**

Before the last date for submission of Tenders, the Employer may modify any of the Contents of the Tender Notice, Tender documents by issuing amendment / Addendum/corrigendum.

Any addendum/amendments/corrigendum issued by the Employer shall be part of the tender Document and it shall be published in the e-procurement portal at <http://www.tripuratenders.gov.in>. Registered Bidders shall be notified of the related Corrigendum(s) by e-mail. However, TSECL shall bear no responsibility or liability arising out of non-receipt of the same in time or otherwise. Bidders are requested to visit the site frequently to check whether there is any related Corrigendum(s) or not.

**19.0 EMPLOYER reserves the right to cancel/withdraw this invitation for bids without assigning any reason and shall bear no liability whatsoever consequent upon such a decision.**

**20.0** The bidder shall bear all **cost and expenses** associated with purchase and submission of its bid document and **TSECL** will not be responsible or liable in any case for those cost, regardless of the conduct or outcome of the bidding process.

Deputy General Manager  
Electrical Division Kamalpur  
Tripura State Electricity Corporation Limited  
Dhalai Tripura



## SECTION-II INSTRUCTION TO BIDDERS

### 1. GENERAL INSTRUCTIONS

The bidders are to satisfy themselves by actual site visit to the site of work as regards the prevailing condition of approaches, transportation facilities, availability of labours and availability of materials etc. before submission of bid. No claim or excuse on this account will be entertained at any stage later on.

The location of the work is under the jurisdiction of Electrical Division-Kamalpur

### 2. COST OF BIDDING

The Bidder shall bear all the costs and expenses associated with preparation and submission of its Bid including post-bid discussions, technical and other presentation etc. and the TSECL shall in no case be responsible or liable for those costs, regardless of the conduct or outcome of the bidding process.

### 3. THE BIDDING DOCUMENT

#### 3.1 CONTENTS OF BIDDING DOCUMENTS

The goods and services required, bidding procedures and contract terms are as prescribed in the Bidding Documents.

In addition to the Invitation for Bids, the Bidding Documents is a compilation of the following sections:

- Section-I Notice Inviting E-Tender**
- Section-II Instructions to Bidders**
- Section-III General Conditions of Contract**
- Section-IV Erection Conditions of Contract**
- Section-V Standard Technical Specification & Guaranteed Technical Particulars**
- Section-VI Special instructions to bidder(s)**
- Section-VII Price Schedule/BoQ**

#### 3.2 UNDERSTANDING OF BIDDING DOCUMENTS

A prospective Bidder is expected to examine all instructions, forms, terms and specifications in the Bidding Documents and fully inform himself as to all the conditions and matters which may in any way affect the scope of work or the cost thereof. Failure to furnish all information required by the Bidding Documents or submission of a Bid not substantially responsive to the Bidding Documents in every respect shall be at the Bidder's risk and may result in the rejection of its Bid.

### 4. CLARIFICATIONS ON BIDDING DOCUMENTS

- 4.1 If prospective Bidder finds discrepancies or omissions in the specifications and documents or is in doubt as to the true meaning of any part or requires any clarification on Bidding Documents should make the request / notify the **Tender inviting Authority** of TSECL in writing. The concerned authority of TSECL shall respond in writing to any request for such clarification of the Bidding Documents, which it receives not later than fifteen (15) days prior to the deadline for submission of bids stipulated in tender notice. Written copies of the response (including an explanation of the query but without identifying its source) shall be sent to all prospective bidders who purchased the tender document.





- 4.2 Verbal clarification and information given from any offices of TSECL or its employee(s) or representative (s) shall not in any way be binding on TSECL.

## 5. CORRIGENDUM /AMENDMENT TO BIDDING DOCUMENTS

- 5.1 At any time prior to the deadline for submission of bids, TSECL may, for any reason, whether at its own initiative or in response to a clarification requested by a prospective Bidder, modify the Bidding Documents by amendment (s).
- 5.2 The amendment(s) will be published in the e-Tender portal at <http://www.tripuratenders.gov.in>. Registered Bidders shall be notified of the related Corrigendum(s) by e-mail. However, TSECL shall bear no responsibility or liability arising out of non-receipt of the same in time or otherwise. Bidders are requested to visit the site frequently to check whether there is any related Corrigendum or not.
- 5.3 In order to afford prospective bidders reasonable time to take the corrigendum/amendment into account in preparing their bids, TSECL may, at its discretion, extend the deadline for submission of bids.
- 5.4 Such corrigendum/amendment, clarifications, etc shall be binding on the bidders and shall be given due consideration by the bidders while they submit their bids and invariably enclose such documents as a part of the Bid.

## 6. PREPARATION OF BIDS

### 6.1. LANGUAGE OF BID

The Bid prepared by the Bidders and all correspondence and documents relating thereto, exchanged by the Bidder and TSECL, shall be written in English language, provided that any printed literature furnished by the bidder may be written in another language so long as accompanied by an English translation of its pertinent passages. Failure to comply with this may disqualify a bid. For purposes of interpretation of the bid, the English translation shall govern.

## 7. LOCAL CONDITIONS

- 7.1. It shall be imperative on each bidder to fully inform him of all local conditions and factors, which may have any effects on the execution of the contract covered under these documents and specifications. The Owner (TSECL) shall not entertain any request for clarification from bidders, regarding such local conditions.
- 7.2. It must be **understood and agreed that such factors as above have properly been investigated and considered while submitting the proposals**. No claim for financial adjustment to the Contract awarded under these specifications and documents shall be entertained by TSECL. Neither any change in the time schedule of the Contract nor any financial adjustments arising thereof shall be permitted by TSECL.

## 8. DOCUMENTS COMPRISING THE BID

The Bid shall be submitted in 2(two) parts, post registration in the <http://www.tripuratenders.gov.in>, as under:

### **Part-I: Envelop-I (Technical Bid):**

1. Containing Tender Fee & Earnest Money as per the stipulations described under the title "Notice Inviting E-Tender" of Section 1 in this Bid Document. No financial aspect will be entertained in technical bid
2. Containing Documentary Evidence of the Bidder fulfilling the Qualifying Requirements stipulated in the NIT / Bid Document along with other necessary documents. The document to be submitted shall include copies of the relevant work order / purchase order / Award letters / Agreements etc. and corresponding completion and performance certificates issued by the concerned clients.



3. Containing Bidders Technical Proposal, GTPs, drawings, etc. along with his Commercial Terms, Payment Terms in conformity with the Bid Documents.

**Bid Envelop-II (Price Bid):**

Only the successfully qualified technical bidders shall be considered for opening of Price bid.

The Price Bid shall be consisting of the following documents:

**Bill of Quantity (BOQ)** i.e. the Price Bidding Schedule - to be downloaded.

Regarding **Bill of Quantity** mentioned as above (BOQ), the Bidder shall download the BOQ file in XLS format from the Tender document. All cells of the XLS document will be protected except the field (Bidder's Name and Rates only in figures), the Bidder is expected to fill in. The BOQ XLS document shall contain bundled Macros which shall have to be enabled for automatic calculations and "figure to word conversions".

**9. SCOPE OF THE PROPOSAL**

- 9.1. The scope of the proposal shall cover site survey, supply, erection, testing and commissioning of "Extension of HT/LT line & installation of 1X5X25 KVA Transformers for improvement of Voltage at different SBDTW schemes ( 1. Srirampur VC near house of Chandra Singh Debbarma, 2. Mayachari GP near house of Shibananada Parshi , 3. Debichara G.P near house of Krishnakanta Sinha 4. Chulubari G.P 4. Near house of Aunturam Gour 5. Near house of Jagannath Gour Chulubari G.P, 6. Mahabir Tea garden no -2 AWC, 7. Ramjatan Koli Mahabir G.P, 8. Debichara G.P near House Birendra Malakar 9. Near house of Ranjit Roy Debichara G.P, 10. Malirai Para at Ashupurna Roaja Para) under ED Kamalpur specified under the accompanying Technical Specification and requirement as per A, &E component.

Sl.No.	Description of Item	QTY	Unit
A	<b>Supply of the Following</b>		
1	9 mtr long PCC Pole	18	No
2	8 Mtr. Long PCC Pole	23	No
3	Stay set complete	25	Set
4	Stay wire, 7/2.50mm( stranded)	0.125	MT
5	Stay insulator(11KV)	10	No
6	11KV, Pin insulator	60	No.
7	11 KV Disc Insulator	60	No.
8	11 KV Disc fittings	60	set
9	MS Channel (100*50*50*6)	0.570	MT
10	MS Channel (75*40*40*6)	0.730	MT
11	MS Angle (65*65*6)	0.160	MT
12	MS Angle (50*50*6)	0.450	MT
13	ACSR Weasel(6/1/2.59 mm)( for 11 Kv Line)	11.6	Km
14	G.I Wire 8 SWG(ISS:280/1978)	0.066	MT
15	LT Shackle insulator (3X3 1/2)"	420	No.
16	LT Straps and bolts	420	Set
17	11Kv G.O Switch ( 3 Phase ), 200 Amp Porcelain type	9	Set
18	11Kv D.O Switch ( 3 Phase)Porcelain type	9	Set



19	LA (11 KV)	15	Nos.
20	Danger Plate	9	No.
21	Wooden Plank made with Segun/Karai tree with all accessories for fittings	5	No.
22	Pipe earthing with all accessories	15	No.
23	PVC cable 70 mm <sup>2</sup> .	0.20	Km
24	Cut-out 100 Amps	15	Nos.
25	Alluminium 120 sq. mm size Thimble	80	No.
26	Stay insulator(LT)	16	No
<b>B.</b>	<b><i>Dismantling of the following :-</i></b>		
1	09 Mt. long PCC Pole	4	Nos
2	08 Mt. long PCC Pole	10	Nos
3	Stay Set Complete	8	Sets
4	0.3 mt 75x40x40x6 mm SP Top Bkt	10	Nos
5	1.2 mt.75x40x40x6 mm SP Bottom Bkt	10	Nos
6	1.5 mt.65X65X6 mm SP Guard Bkt.	8	Nos
7	11 KV bracket(1.7 mtr long DP TOP Bracket ch.75)	1	Nos
8	11kv bracket(2.5 mtr long DP Guard Bracket ang. 65)	1	Nos
9	MS angle X-arm bracket of 4 wire 1.1 mtr. Long	10	Nos
10	MS angle X-arm bracket of 2 wire 0.6 mtr. Long	10	Nos
11	Shakle insulator with Nuts & Bolts	60	Nos
12	11 KV polymer pin insulator.	33	Nos
13	11 KV single Disc polymer insulator set with fittings	33	Nos
14	ACSR 6/1/2.59 mm weasel (for 11 kv & LT line)	5.00	km
15	8 SWG GI wire	1.10	km
16	1-phase Service connection	25	Nos
17	3-phase Service connection	5	Nos
<b>C.</b>	<b><i>Re-erection of the Dismantling items</i></b>		
1	09 Mt. long PCC Pole	4	Nos
2	08 Mt. long PCC Pole	10	Nos
3	Stay Set Complete	8	Sets
4	0.3 mt 75x40x40x6 mm SP Top Bkt	10	Nos
5	1.2 mt.75x40x40x6 mm SP Bottom Bkt	10	Nos
6	1.5 mt.65X65X6 mm SP Guard Bkt.	8	Nos
7	11 Kv bracket(1.7 mtr long DP TOP Bracket ch.75)	1	Nos
8	11kv bracket(2.5 mtr long DP Guard Bracket ang. 65)	1	Nos
9	MS angle X-arm bracket of 4 wire 1.1 mtr. Long	10	Nos
10	MS angle X-arm bracket of 2 wire 0.55 mtr. Long	10	Nos
11	Shakle insulator with Nuts & Bolts	60	Nos
12	11 KV polymer pin insulator.	33	Nos
13	11 KV single Disc polymer insulator set with fittings	33	Nos
14	ACSR 6/1/2.59 mm weasel (for 11 kv & LT line)	5.00	km
15	8 SWG GI wire	1.10	km
16	1-phase Service connection	25	Nos



17	3-phase Service connection	5	Nos
<b>D</b>	<b>Erection of the New Supply Materials</b>		
1	09 Mt. long PCC Pole	18	Nos
2	08 Mt. long PCC Pole	23	Nos
3	Stay Set Complete	25	Sets
4	Erection of Wooden Plank made with Segun/Karai tree with all accessories for fittings	5	Nos
5	2.8 mt.long 100X40X40X6 mm ms channel Sub-Station Top bracket (line channel)	9	Nos
6	2.8 mt.long 75X40X40X6 mm ms channel for line Gang & Sub-Station (for GOS base & DOF unit base)	36	Nos
7	2.8 mt.long 100X50X50X6 mm ms channel Sub-Station bracket (for Txr base)	10	Nos
8	0.8 mt.long 100X50X50X6 mm ms channel Sub-Station bracket (for Txr cross bracket)	10	Nos
9	2.8 mt.long 65X65X6 mm ms angle for GOS Handle bracket	9	Nos
10	MS angle X-arm bracket of 4 wire 1.1 mtr. Long	40	Nos
11	MS angle X-arm bracket of 2 wire 0.55 mtr. Long	90	Nos
12	Shakle insulator with Nuts & Bolts	420	Nos
13	11 KV polymer pin insulator.	60	Nos
14	11 KV single Disc polymer insulator set with fittings	60	Nos
15	ACSR 6/1/2.59 mm weasel (for 11 kv & LT line)	11.60	km
16	8 SWG GI wire	0.70	km
17	11 KV GOS Set of 3 (three) phase	9	set
18	11 KV DOF unit set of 3 (three) phase.	9	set
19	Erection & commissioning of 11/0.430 KV,25 KVA three phase distribution transformer including all accessories	5	Nos
20	Sub-station Earthing by GI pipe 2.5 mtr. Long 40 mm dia i/c earth excavation and refilling with alternate layer of salt and charcoal, GI pipe,clamps, nuts & bolts.	15	Nos
21	Supply of 2.5 mtr long 40mm dia GI PIPE	15	NOS
22	Supply of 60kg Salt & 55 kg charcoal( For each pit)	15	pit
<b>E</b>	<b>Supply/Providing of the following materials :-</b>		
1	MS clamp made by 50X6 mm MS flate for bracket i/c 16X75 mm Nuts & bolt.	265	Nos.
2	MS clamp made by 50X6 mm MS flate for stay set & strain screw i/c 16X75 mm Nuts & bolt.	25	pair
3	Supply and erection of sub-station fencing with erection of 10 nos. 2.5 mt long (65X65X6 mm) MS Angle post with grouting of Vol 0.045 cum at the ratio of 1:2:4 (1 cement: 2 river sand: 4 jhama bri ck aggregate) per post.The fencing should be made 9(nine) horizontal of barbed wire and one gate with shutter (2X1.7)m i/c locking arrangement etc.complete as per direction of the Engineer-in-charge.	5	job
4	Supply of 4 sq.mm. PVC wire for service connection	0.50	km
5	Supply of 10 sq.mm. PVC wire for service connection	0.1	km
<b>F</b>	Carriage of DTR from MMD Division Agartala to to Work Site	2	trip
<b>G</b>	Carriage of 9 mtr length of P.C.C poles by Machnical Transport Beyond 25 KM upto the lead of 50 KM	5	trip



<b>H</b>	Carriage of 8 mtr length of P.C.C poles by Machnical Transport Beyond 25 KM upto the lead of 50 KM	5	<i>trip</i>
<b>I</b>	Maintaining adequate clearance from overhead live conductors by trimming of tree branches for way leaves	12	<i>km</i>
<b>J</b>	<b>Stratenining/ stringing of the following:-</b>		
<b>1</b>	9mtr Steel pole	10	Nos
<b>2</b>	9mtr PCC Pole	25	Nos
<b>3</b>	8 mtr. PCC pole	25	Nos
<b>4</b>	8 mtr. Steel pole	10	Nos
<b>5</b>	A.C.S.R.6/1/2.59 mm	12	km

The Bidder should strictly adhere to the quantity of materials as specified in A, and E component for construction of HT/LT lines, Sub-Stations and providing Service connection to DWS schemes and SBDTW. Maximum + 10% variation of the above-mentioned materials (A, E) for per kilometre shall be allowed subject to site condition and with the prior approval of Engineer-in-charge of the work and for these any additional cost i/c materials shall be borne by the successful bidder.

All materials supplied by the successful Bidder shall mandatorily have the words "TSECL-DWS/2024-25" embossed/engraved on them. Materials supplied by the bidder without engraving "TSECL-DWS/2024-25" shall not be accepted by bidder.

- 9.2. Bids containing deviations from provisions relating to the following clauses shall be considered as 'non-responsive':
- Price Basis and Payments & Price Adjustment:  
Clause 12.0 (Section-II,) 32.0& 33.0 (Section-III,)
  - Bid Guarantee:  
Clause 8.0, Section-I
  - Contract Performance Guarantee:  
Clause 11.0, Section-I
  - Liquidated Damages:  
Clause 13.0, General Condition of Contract (Section-III)
  - Guarantee:  
Clause 14.0, Section-III
  - Payment:  
Clause 33.0, Section-III.

The determination of a Bid's responsiveness will be based on the contents of the Bid itself without recourse to extrinsic evidence.

- 9.3. Bids not **covering the above entire Scope of Work** shall be treated as incomplete and hence rejected.

## 10. BID PRICE

10.1 The Bidder shall quote unit rates as per the downloaded **BOQ XLS** file and upload the same in Financial Part of the Tender.

## 11. ALTERNATE PROPOSALS

11.1. Bidder shall submit offers that comply with the requirements of the bidding documents, **including** the basic technical design as indicated in the drawing and specifications. Alternatives will not be considered.

## 12. PRICE BASIS AND PAYMENTS

12.1. The bidders shall quote in their proposal price for the entire Scope of Supply covered under the Technical Specification as required in the "How to Quote Price" in this Section followed by BOQ.



12.2. Bidder shall indicate Bid prices in Indian Rupees only

### 13. TAXES AND DUTIES

13.1. Price Shall be quoted in Rupees only, in the BoQ uploaded in the portal. **Quoted Prices shall be FIRM and inclusive of all cost of labour, insurance, EPF charges, spares, T&Ps, all consumables & materials and all applicable tax and duties.**

13.2. **Goods and Services Tax (GST)** as applicable on twenty-eight (28) days prior to deadline for submission of bids, shall be mentioned in the BoQ/Price Bid.

13.3. **Applicable GST shall be reimbursed by TSECL on submission of actual documentary proof based on tax invoices raised by the contractor.**

13.4. **Statutory** variation in Taxes & duties after twenty-eight (28) days prior to deadline for submission of bids and during the scheduled completion period will be adjusted / reimbursed against production of documentary evidence.

13.5. **Income** Tax as admissible will be deducted at source for which necessary TDS certificate will be issued”

### 14. TIME SCHEDULE

14.1. The basic consideration and the essence of the Contract shall be strict adherence to the time schedule for performing the specified works.

14.2. The completion schedule as stated in ITB 14.3 shall be one of the major factors in consideration of the Bids.

14.3. **TSECL reserves the right to request for a change in the work schedule during post-bid discussion with successful bidder.**

Indicative timelines from effective date (in Months) (D = Date of issuing of LOA)	Indicative Key Activities	Volume of work
D+3 (3 months)	Providing Single phase service connection at small bore Deep tube well at different locations.	i. 10% of the total quantity given in the tender document/BOQ.
D+4 (1 months)	i. Providing Single phase service connection at small bore Deep tube well at different locations. ii. Providing Three phase service at DTW Scheme, at different location.	i. 10% of the total quantity given in the tender document/BOQ. ii. 20% of the total quantity given in the tender document/BOQ including HT&LT line and sub-station.
D+5 (1 months)	i. Providing Single phase service connection at small bore Deep tube well at different locations. ii. Providing Three phase service at DTW Scheme, at different location.	i. 10% of the total quantity given in the tender document/BOQ. ii. 10% of the total quantity given in the tender document/BOQ including HT&LT line and sub-station.
D+6 (1 months)	i. Providing Single phase service connection at small bore Deep tube well at different locations. ii. Providing Three phase service at DTW Scheme, at different location.	i. 10% of the total quantity given in the tender document/BOQ. ii. 10% of the total quantity given in the tender document/BOQ including HT&LT line and sub-station.
D+7 (1 months)	i. Providing Single phase service connection at small bore Deep tube well at different locations.	i. 10% of the total quantity given in the tender document/BOQ. ii. 10% of the total quantity given





	ii. Providing Three phase service at DTW Scheme, at different location.	in the tender document/BOQ including HT&LT line and sub-station.
<b>D+8 (1 months)</b>	i. Providing Single phase service connection at small bore Deep tube well at different locations. ii. Providing Three phase service at DTW Scheme, at different location.	i. 10% of the total quantity given in the tender document/BOQ. ii. 10% of the total quantity given in the tender document/BOQ including HT&LT line and sub-station.
<b>D+9 (1 months)</b>	i. Providing Single phase service connection at small bore Deep tube well at different locations. ii. Providing Three phase service at DTW Scheme, at different location.	i. 10% of the total quantity given in the tender document/BOQ. ii. 10% of the total quantity given in the tender document/BOQ including HT&LT line and sub-station.
<b>D+10 (1 months)</b>	i. Providing Single phase service connection at small bore Deep tube well at different locations. ii. Providing Three phase service at DTW Scheme, at different location.	i. 10% of the total quantity given in the tender document/BOQ. ii. 10% of the total quantity given in the tender document/BOQ including HT&LT line and sub-station.
<b>D+11 (1 months)</b>	i. Providing Single phase service connection at small bore Deep tube well at different locations. ii. Providing Three phase service at DTW Scheme, at different location.	i. 10% of the total quantity given in the tender document/BOQ. ii. 10% of the total quantity given in the tender document/BOQ including HT&LT line and sub-station.
<b>D+12 (1 months)</b>	i. Providing Single phase service connection at small bore Deep tube well at different locations. ii. Providing Three phase service at DTW Scheme, at different location.	i. Balance quantity left for completion of the work or 10% of the total quantity given in the tender document/BOQ.  ii. Balance quantity left for completion of the work or 10% of the total quantity given in the tender document/BOQ including HT&LT line and sub-station.

14.4. The successful Bidder shall be required to submit detailed BAR CHART and finalize the same with TSECL, as per the requirement of completion schedule.

**15. CONTRACT QUALITY ASSURANCE**

15.1. The Bidder shall include in his proposal, the quality assurance programme containing the overall quality management and procedures which he proposed to follow in the performance of the works during various phases, as detailed in relevant clause of the General Technical Conditions.

15.2. At the time of award of Contract, the detailed quality assurance programme to be followed for the execution of the contract shall be mutually discussed and agreed to and such agreed programme shall form part of the contract.

**16. INSURANCE**

The bidder's insurance liabilities pertaining to the Scope of Work is detailed out in clauses titled insurance in General Terms & Conditions of Contract and in Erection Conditions of Contract. Bidder's attention is specifically invited to these clauses. The bid price shall include all the cost in pursuance of fulfilling all the insurance liabilities under the Contract.

**17. BRAND NAMES**



All the equipment's/ materials/ PCC Pole/Insulators/ Cable/ Steel Sections/Cable/Steel poles/ACSR/ Hardware & Stay Sets/Spares etc. shall be supplied as per the attached technical specification. Any deviation in this regard shall not be entertained. In case brand names are not specified in the attached technical specification, standard equipment's / materials of reputed manufacturer acceptable to TSECL shall be supplied.

## 18. BID GUARANTEE

- 18.1. The Bidder shall furnish, as part of its Bid, earnest money for an amount as specified in the Notice Inviting Tender (NIT) in the shape of demand draft only in favour of Tripura State Electricity Corporation Limited payable at Agartala, and West Tripura.
- 18.2. The earnest money is required to protect TSECL against the risk of Bidder's conduct, which would warrant the earnest money forfeiture pursuant to Para 18.7.
- 18.3. The earnest money shall be deposited in Indian rupees only.
- 18.4. Any bid not secured in accordance with para 18.1 and 18.3 above shall be rejected by TSECL as non-responsive.
- 18.5. The earnest money of the unsuccessful Bidders shall be discharged /returned as per clause 8.0 of Section – I.
- 18.6. **The earnest money shall be forfeited:**
- a. If a Bidder withdraws its bid during the period of bid validity specified by the Bidder on the bid form; or
  - b. In case of a successful Bidder fails:
    - i) to sign the contract; or
    - ii) to furnish the 'Contract Performance Guarantee'.
- 18.7. No interest shall be payable by TSECL on the above earnest money.

## 19. PERIOD OF VALIDITY OF BIDS

- 19.1. Bids shall remain valid for **6 (six) calendar** months after the date of bid opening prescribed by TSECL, unless otherwise specified in the accompanying Special Conditions of Contract. A Bid valid for a shorter period shall be rejected by TSECL as non-responsive.
- 19.2. In exceptional circumstances, TSECL may solicit the Bidder's consent to an extension of the period of Bid validity. The request and the response thereto shall be made in writing (including cable or fax). The Earnest money provided under Clause 6.0 of Section – I shall also be retained up to the extended period. No interest shall be payable by TSECL for retaining the earnest money upto the extended period. A Bidder may refuse the request without forfeiting the earnest money deposited by him. A Bidder granting the request shall not be required or permitted to modify his Bid.

## SUBMISSION OF BIDS

### 20. FORMAT OF BID

- 20.1. Bids are to be submitted online through the website, and as, stated in Clause 1.0 and 2.0 and 3.0. All the Bidding documents (SBD, Scan copy of tender fee) uploaded by the TSECL form an integral part of the contract. Bidders are required to upload these bidding documents as asked for in the Bid, through the above website and within the stipulated date and time mentioned in the Tender.

Tenders are to be submitted in two folders at a time for each work, one for Technical Proposal and the other for Financial Proposal. The Bidder shall carefully go through the requirements and prepare the required documents to be uploaded.

In Technical Bid, Bidder shall have to submit the entire requisite document as specified in the SBD (SBD, Scan copy of tender fee and EMD , All forms / Amendments / Formats / Annexure with supporting



documents/certificates, Technical Data Sheet/GTPs and drawings, Test Reports, Financial, Tax related document, machinery & manpower details specified in the Bid Document etc.

In, Financial Bid Bidder shall upload BoQ in the financial Bid.

The bidder shall scan all the documents before uploading and all scanned documents shall be of 100 dpi resolution in Portable Document Format (PDF). The scanned documents shall be uploaded in the designated locations of Technical Bid and Financial Bid, as prompted by the e-Procurement website.

The Bidder needs to fill up their name and rates for all the items and in the designated Cells of the downloaded BOQ for the related work, and upload the same in the designated location of Financial Bid. The documents uploaded are virus scanned and digitally signed using the Digital Signature Certificate (DSC). Bidders shall specially take note of all the addendum/corrigendum related to the tender and upload the latest documents as part of the tender.

### **Bid Envelop-I (Technical Bid):**

The Technical Bid/Bid Envelop-I should contain scanned copies and/or declarations in the following standardized formats.

#### **A. My Document (Non-Statutory):**

All the below-mentioned documents/certificates are to be uploaded with digital signature in the 'My Document' folder option available after login in the e-procurement portal <http://tripuratenders.gov.in>. Bidders are requested to scan the necessary documents in 100 dpi resolution into PDF. 'My Document' shall be populated prior to real time bidding and during real time bidding, uploaded documents/certificates in the 'My Document' are to be appropriately included (Checked) for incorporation in the Bid.

An indicative organization of 'My Document' folder and the related documents are indicated here under.

Sl.	Folder Name	Documents to be uploaded
1.	Mfglic	<b>Company Details:</b> II. <b>Registration of the firm/Partnership deed/ Articles of Association/Joint Venture/consortium.</b>
2.	DNIT Documents	II. Corrigendum, if published
3.	Machinery Details	Machinery & Manpower in possession of the firm:
4.	Tax related document	III. GST Registration certificate V. IT PAN
5.	Financial details	II. Audited Balance Sheets of last five financial years with auditor's certificate regarding annual turnover i/c IT Return Certificate from contracting business in each year.
6.	Misc. document	V. Electrical Contractor License & supervisory certificate VI. Valid Labour License



	III. Any other important document.
--	------------------------------------

### **B. Statutory Documents:**

After uploading the above mentioned non-statutory documents/certificates, Bidders shall submit the following, during real time bidding

1. NIT.
2. Bid Document.
3. All annexure/ formats/certificates i/c supporting documents/certificates in support of qualifying requirement other than mentioned in My Document specified in the Bid Document in single PDF.
4. Technical Data Sheet/GTPs, Guarantee/Test report etc. offered by the original manufacturer and drawings specified in the Bid Document

**Note-1:** Failure of submission of any one of the above-mentioned documents shall render the tender to summarily rejection.

**Note-2:** If the company was set up less than three years ago, audited balance sheet for the no of years since inception is to be submitted.

**Note-3:** Bidders are requested to scan the necessary documents/certificates in **100 dpi** resolution into PDF.

### **Bid Envelop-II (Financial Bid):**

Documents to be submitted in the Financial Bid are:

1. BOQ (Bill of quantity/Price schedule).

**Note:** Bill of Quantity (BOQ) i.e. Price schedule, which is the Rate quoting sheet in MS-excel shall be downloaded, filled up properly and uploaded in the financial bid after digital signing. The Bidder shall always open the BOQ sheet with Macros Enabled. The Bidder shall quote rates in figures only, for all items in the Bill of Quantity (BOQ).

- 20.2. **BOQ (Price Schedule) TAMPERING:** The provided BOQ (Price schedule) in the Tender is meant for downloading in the Bidders client machine, for entering the relevant fields meant for rates & bidder's particulars and finally uploading in the Financial Bid. The BOQ Excel Sheet is Macro enabled and working with the Sheet requires the Macro to be allowed/ enabled to run.
- 20.3. Bidders are hereby warned not to tamper the Excel Sheet, make copies and work in a copied Sheet or break through the default Work-Sheet Security. Such BOQs with stated violations will be treated as Tampered BOQs and Bids uploaded with Tampered BOQs will be summarily rejected.
- 20.4. Bidders are allowed to bid 24x7 till the time of Bid closing, with option for Re-Submission, wherein only their latest submitted Bid will be considered for evaluation. The e-Procurement website will not allow any Bidder to attempt bidding, after the scheduled date and time.
- 20.5. For any clarification related to NIT/SBD/e-procurement, bidder(s) are requested to contact:

Deputy General Manager



Electrical Division Kamalpur  
Tripura State Electricity Corporation Limited

## 21. SIGNATURE OF BIDS

- 21.1. Bid by a partnership must be furnished with full names of all partners and be signed with the partnership name, followed by the signature(s) and designation(s) of the authorized partner(s) or other authorized representative(s) and as per Section I & II of the BID.
- 21.2. Bids by Corporation / Company must be signed with the **legal name of the Corporation/Company** by the President, Managing Director or by the Secretary or other person or persons authorized to Bid on behalf of such Corporation / Company in the matter.
- 21.3. A Bid by a person who affixes to his signature the word 'President', 'Managing Director', 'Secretary', 'Agent', or other designation without disclosing his principal shall be rejected.
- 21.4. Satisfactory evidence of authority of the person signing on behalf of the Bidder shall be furnished with the Bid.
- 21.5. The Bidder's name stated on the proposal shall be exact legal name of the firm.
- 21.6. Bids not conforming to all the above requirements of para 21.0 above may be disqualified.
- 21.7. The original tender document shall be **digitally signed** by the bidder and will be uploaded during the e-Bid as part of the financial bid.

## 22. SEALING AND MARKING OF BIDS

~~The Bidder shall have to deposit both the original Demand Drafts against related Tender Fee and EMD in a sealed envelope depicting NIT No. and the Bidders Name & Address at "O/O General Manager Technical, Tripura State Electricity Corporation Limited, Corporate Office, BidyutBhaban, Agartala, Tripura (West).Pin: 799001" on or before 1.00 P.M.,10.04.2019.~~

~~If the outer envelope is not sealed and marked as required by para 22.2 (b), TSECL shall assume no responsibility for the Bid's misplacement or premature opening.~~

## 23. DEADLINE FOR SUBMISSION OF BIDS

- 23.1. TSECL may, at its discretion, extend this deadline for the submission of Bids, in which case all rights and obligations of TSECL and Bidders previously subject to the deadline shall thereafter be subject to the deadline as extended.

## 24. MODIFICATION AND WITHDRAWAL OF BIDS

- 24.1. Withdrawal of Bid is not permitted.
- 24.2. The Bidder may Revise (modify) his Bid as many number of times he wants, till the point of Tender Closing. In such case, only his last modified Bid would be considered for evaluation.

## 25. INFORMATION REQUIRED WITH THE PROPOSAL

- 25.1. The Bids must clearly indicate the name of the manufacturer, the type of model of each principal item of equipment proposed to be furnished and erected. The Bid shall also contain drawings and descriptive materials indicating general dimensions, principles of operation, the extent of pre-assembly involved, major construction equipment proposed to be deployed, method of erection and the proposed erection organizational structure.
- 25.2. **The above information shall be provided by the Bidder in the form of separate sheets, drawings, catalogues, etc. in five copies.**
- 25.3. Any bid not containing sufficient descriptive material to describe accurately the equipment proposed, shall be treated as incomplete and hence rejected. Such descriptive materials and drawings submitted by the Bidder shall be retained by TSECL. Any major departure from these drawings and



descriptive material submitted shall not be permitted during the execution of the Contract without specific written permission of TSECL.

- 25.4. Oral statements made by the Bidder at any time regarding quality, quantity or arrangement of the equipment or any other matter shall not be considered.
- 25.5. Standard catalogue pages and other documents of the Bidder may be used in the Bid to provide additional information and data as deemed necessary by the Bidder.
- 25.6. **In case the proposal information contradicts specification requirements; the specification requirements shall govern, unless otherwise brought out clearly in the technical / commercial deviation schedule.**

### **BID OPENING AND EVALUATION**

#### **26. OPENING OF BIDS BY TSECL**

- 26.1. The Employer will designate Tender Opening Authority for each and every Bid separately, and the technical bids will be opened online by them at the time and date, as specified in the NIT/ Standard Bid Documents.
- 26.2. All the Statements, Documents, Certificates, Demand Draft / Bank Guarantee etc. submitted/uploaded by the Bidders will be verified for technical evaluation. The clarifications and particulars, if any, required from the bidders, will be obtained by addressing the bidders directly. The technical bids will be evaluated against the specified parameters/ criteria mentioned in the BID, and in the same process as done in the case of conventional tenders. The technically qualified bidders will be identified and considered for their Financial Bid opening. The result of Technical Bids evaluation shall be displayed in the e-procurement portal and all the Bidders who have participated in the Tender will be able to access the same.
- 26.3. The Bidders or their authorized representatives may remain present at the time of opening of the tenders. Either the Bidder himself or one of his representatives with proper authorization only will be allowed at the time of tender opening. If any of the Bidders is not present at the time of opening of tenders, the tender opening authority will, on opening the tender of the absentee Bidder, read out and record the deficiencies if any, and this will be binding on the Bidder.
- 26.4. The Minutes of the Technical bid opening shall be recorded and signed by the Tender Opening Authority as well as Bidders or their Authorized Representatives present and the same shall be uploaded and can be accessed in the e-procurement portal.
- 26.5. The Price bids (Financial bids) of all the technically qualified bidders will be opened by the concerned Tender Opening Authority at the specified date and time. The same can be tracked through the e-procurement portal by all the technically qualified bidders who participated in the tender. However, Qualified Bidders or their authorized representatives may remain present at the Price Bid (Financial bid) opening.
- 26.6. The Financial Bid's Item-wise Rates and total amount shall be read out, Minutes of the Bid opening shall be recorded and the Bidder's signatures will be taken in the minutes. The result of financial bids (Price bids) evaluation shall be displayed in the e-procurement portal and Bidders can access the same
- 26.7. The 'BOQ comparative chart' generated & displayed from the e-procurement portal, after the opening of financial Bid (which will be displayed as 'BOQ comparative chart' at financial bid opening summary page), will not be final.
- 26.8. Employer will prepare comparative Statement as per the decision of the Financial Bid Evaluation Committee in the Employer, which will be appropriately displayed in the e-procurement portal (this will be displayed at financial bid opening summary page).
- 26.9. The Price Bid (Financial Bid) of the Unqualified Bidders will not be opened

#### **27. CLARIFICATION OF BIDS**





- 27.1. During in the examination, evaluation and comparison of Bids, TSECL may, at its discretion, ask the Bidder for a clarification in writing before opening of Price bid Once Price bid is opened no clarification will be done.

## 28. PRELIMINARY EXAMINATION

- 28.1. TSECL shall examine the Bids to determine whether they are complete, whether any computational errors have been made, whether required sureties have been furnished, whether the documents have been properly signed and whether the Bids are generally in order.
- 28.2. The Bidder shall ensure that the prices furnished by him are complete. In the case of not quoting of rates of any item (supply/erection) in the downloaded BOQ XLS file, TSECL shall be entitled to consider the highest price of the tender for the purpose of evaluation and for the purpose of evaluation and for the purpose of award of the Contact, use the lowest prices of the tender:
- 28.3. Prior to the detailed evaluation, TSECL shall determine the substantial responsiveness of each Bid w.r.t. Bidding Documents. For purpose of these Clauses, a substantially responsive Bid is one which conforms to all the terms and conditions of the Bidding Documents without material deviations. A material deviation is one which affects in any way the prices, quality, quantity or delivery period of the equipment or which limits in any way the responsibilities or liabilities of the Bidder or any right of TSECL as required in these specifications and documents. TSECL determination of a Bid's responsiveness shall be based on the contents of the Bid itself without recourse to extrinsic evidence.
- 28.4. A Bid determined as not substantially responsive shall be rejected by TSECL and may not subsequently be made responsive by the Bidder by correction of the non-conformity.
- 28.5. TSECL may waive any minor non-conformity or irregularity in a Bid which does not constitute a material deviation, provided such waiver does not prejudice or affect the relative ranking of any Bidder.

## 29. DEFINITIONS AND MEANINGS

- 29.1. For the purpose of the evaluation and comparison of bids, the following meanings and definition shall apply: -
- 'Bid Price'** shall mean the base price quoted by each Bidder in his proposal for the complete scope of works.
  - "Cost Compensation for Deviations"** shall mean the Rupee value of deviations from the Bidding Documents, as determined from the Bidder's proposal.
  - "Evaluated Bid Price"** shall be the summation of 'Bid Price', 'Differential Price' and 'Cost Compensation for Deviations'.
- 29.2. Calculation of Differential Price & Cost Compensation for Deviations.
- 29.3. **Deviations from the Bidding Documents in so far as practicable shall be converted to a Rupee value and added to the Bid Price to compensate for the deviation from the Bidding Documents while evaluating the Bids. In determining the Rupee value of the deviations, TSECL shall use parameters consistent with those specified in the specifications and documents and/or other information as necessary and available to TSECL.**

## 30. COMPARISON OF BIDS

- 30.1. For comparison purposes all the evaluated bid prices shall be in Indian Rupee as under: -

$$W = M + D$$

Where,

$$W = \text{Total Comparison Price}$$



- M = Bid Price including ex-works value of equipment/ materials and other taxes & duties including local taxes, freight and insurance charges, cost of erection /services including works contract tax and other components of bid price, if any.
- D = Cost compensation for deviations calculated according to para 29.3. above.

30.2. Evaluated bid prices of all the bidders shall be compared among themselves to determine the lowest evaluated Bid and, as a result of this comparison, the lowest Bid shall be selected for consideration of award of the Contract.

### 31. CONTACTING THE OWNER

Bids shall be deemed to be under consideration immediately after they are opened and until such time official intimation of award/rejection is made by TSECL to the Bidders. While the bids are under consideration, Bidders and/or their representatives or other interested parties are advised to refrain from contacting by any means, the Owner and/or his employees/representatives on matters relating to the bids under consideration. TSECL, if necessary, shall obtain clarifications on the bids by requesting for such information from any or all the Bidders, either in writing or through personal contacts as may be necessary. Bidders shall not be permitted to change the substance of the bids after the bids have been opened.

### AWARD OF CONTRACT

### 32. AWARD CRITERIA

- 32.1. TSECL shall award the Contract to the successful Bidder whose bid has been determined to be substantially responsive and has been determined as technically acceptable and lowest evaluated Bid, provided further that the Bidder is determined to be qualified to perform the Contract satisfactorily. TSECL shall be the sole judge in this regard.
- 32.2. Further, TSECL reserves the right to award separate Contracts to two or more parties in line with the terms and conditions specified in the accompanying Technical Specifications.

### 33. OWNER'S RIGHT TO ACCEPT ANY BID AND TO REJECT ANY OR ALL BIDS

- 33.1. TSECL reserves the right to accept or reject any bid, and to annul the bidding process and reject all bids at any time prior to award of contract, without thereby incurring any liability to the affected Bidder or Bidders or any obligation to inform the affected Bidder or Bidders of the grounds for such action.

### 34. NOTIFICATION OF AWARD

- 34.1. Prior to the expiration of the period of bid validity and extended validity period, if any, TSECL shall notify the successful Bidder in writing by registered letter or by telex or FAX, to be confirmed in writing by registered letter, that his Bid has been accepted.
- 34.2. The Notification of Award/Letter of Award shall constitute the formation of the Contract.
- 34.3. **Upon the successful Bidder's furnishing of Contract Performance Guarantee pursuant to Clause 11.0 of Section – I. TSECL shall promptly notify each unsuccessful Bidder and will discharge its bid guarantee, pursuant to **Clause 8** (Section – II)**

### 35. SIGNING OF CONTRACT

- 35.1. At the same time as TSECL notifies the successful Bidder that its bid has been accepted, TSECL shall send the Bidder the detailed Letter of Award.  
Within 15(fifteen) days of receipt of the detailed Letter of Award, the successful Bidder shall convey in writing unconditional acceptance of the Letter of Award and shall attend the respective office of TSECL for signing the contract agreement.



### 36. CONTRACT PERFORMANCE GUARANTEE

- 36.1. On award of work the successful bidder shall have to deposit a contract performance guarantee (CPG) equivalent to 10% of the LOA value / Supply order value in the shape of Demand Draft in favour of “Tripura State Electricity Corporation Limited” from any schedule Bank guaranteed by Reserve Bank of India, payable at Kamalpur or in the shape of Bank Guarantee from a Public sector / scheduled Indian Bank guaranteed by Reserve Bank of India. The CPG shall remain valid for actual delivery period plus guarantee period against the item (CPG is to be extended further subject to actual delivery period).
- 36.2. Earnest Money (EM) deposited will be merged / adjusted towards Contract Performance Guarantee (CPG) in the shape of **Demand Draft/Banker Cheque** in favour of **TRIPURA STATE ELECTRICITY CORPORATION LIMITED** from any schedule bank guaranteed by Reserve Bank of India payable at Agartala or in the shape of **Bank guarantee** from a **Public Sector / Scheduled Indian Bank guaranteed by Reserve Bank of India** (the latest annual report of the Bank should support compliance of capital adequacy ratio requirement) in the form attached as **Annexure – I** in favour of TRIPURA STATE ELECTRICITY CORPORATION LIMITED. The guarantee amount shall be equal to ten percent (10%) of the Contract Price and it shall guarantee the faithful performance of the Contract in accordance with the terms and conditions specified in these documents and specifications. The earnest money deposited at the time of tender shall be adjusted with the contract performance guarantee.
- The contract performance guarantee submitted in the shape of Bank guarantee shall be valid for actual execution period of the contract and up to guarantee period as per Clause – 14 of section – III. The performance security of a joint venture/consortium shall be in the name of Lead Partner of the joint venture.**
- 36.3. The Performance Guarantee shall cover additionally the following guarantees to TSECL:
- a. The successful Bidder guarantees the successful and satisfactory operation of the equipment supplied and erected under the Contract, as per the specifications and documents.
  - b. The successful Bidder further guarantees that the equipment provided and installed by him shall be free from all defects in design, material and workmanship and shall upon written notice from TSECL fully remedy free of expenses to TSECL such defects as developed under the normal use of the said equipment within the period of guarantee specified in the relevant clause of the General Terms and conditions.
- 36.4. The Contract Performance Guarantee is intended to secure the performance of the entire contract. However, it is not to be construed as limiting the damages under clause entitled “Equipment Performance Guarantee” in Technical Specifications and damages stipulated in other clauses in the Bidding Documents.
- 36.5. The Contract performance Guarantee submitted in the shape of demand draft shall be returned to the Contractor without any interest at the end of successful completion and commissioning of the work against a Bank Guarantee of equivalent amount from any Public Sector / scheduled Indian Bank valid up to the Guarantee period. The Bank Guarantee such deposited shall be discharged after expiry of Guarantee period.

#### **Additional Contract Performance Guarantee: -**

For bid up to 15% less than the estimated value of work, no additional security deposit is required. But for bid less than 15% of the estimated value of work, the difference between the quoted amount and 85% of the estimated value of work, shall be paid by the successful bidder at the time of concluding the agreement as an additional security to fulfill the contract through Bank Guarantee or



Demand Draft on a Nationalized Bank/Scheduled Bank in the prescribed Format valid till the completion of the work in all respect.

**36.6. The contract performance Guarantee shall be forfeited: -**

- a) **If the contractor fails to start the work as per approved BAR CHART for reasons solely rest on him.**
- b) **If the contractor left / suspends the work without prior written intimation to the owner's Engineer in charge of the work stating the reasons for such suspension of work.**
- c) **If the contractor left / suspends the work for reasons which are not acceptable to TSECL.**

**37. CORRUPT OR FRAUDULENT PRACTICES**

37.1. TSECL expects the bidders / suppliers / contractors to observe the highest standards of ethics during the procurement and execution of such contracts. In pursuance of this policy, TSECL

- a. defines, for the purpose of this provision, the terms set forth below as follows;
  - I. "Corrupt practice" means offering, giving, receiving or soliciting of anything of value to influence the action of a official in the procurement process or in contract execution, and
  - II. "Fraudulent practice" means a misrepresentation of facts in order to influence a procurement process or the execution of a contract to the detriment of the owner, and includes collusive practice among bidders (prior to or after bid submission) designed to establish bid prices at artificial non-competitive levels and to deprive the owner from the benefits of free and open competition.
- b. Will reject a proposal for award if it determines the bidder recommended for award has engaged a corrupt or fraudulent practice in competing for the contract in question.
- c. Will declare a firm ineligible, either indefinitely or for a stated period of time, if TSECL at any time determines that the firm has engaged in corrupt / fraudulent practices in competing for, or in executing the contract.



### SECTION-III

#### GENERAL TERMS & CONDITIONS OF CONTRACT

#### A. INTRODUCTION

##### 1.0 DEFINITION OF TERMS

- 1.1 'The Contract' means the agreement entered into between Tripura State Electricity Corporation Limited and Contractor as per the Contract Agreement signed by the parties, including all attachments and appendices thereto and all documents incorporated by reference therein.
- 1.2 'Owner' shall mean **TRIPURA STATE ELECTRICITY CORPORATION LIMITED (TSECL)** and shall include their legal representatives, successors and assigns.
- 1.3 '**Contractor**' or '**Manufacturer**' shall mean the Bidder whose bid shall be accepted by TSECL for award of the Works and shall include such successful Bidder's legal representatives, successors and permitted assigns.
- 1.4 '**Sub-contractor**' shall mean the person named in the Contract for any part of the Works or any person to whom any part of the Contract has been sublet by the Contractor with the consent in writing of the owner's Engineer in charge of the work and shall include the legal representatives, successors and permitted assigns of such person.
- 1.5 '**Consulting Engineer**'/'**Consultant**' shall mean Power Grid Corporation of India Ltd. or any firm or person duly appointed as such from time to time by TSECL.
- 1.6 The terms '**Equipment**', '**Stores**' and '**Materials**' shall mean and include equipment, stores and materials to be provided by the Contractor under the Contract.
- 1.7 '**Works**' shall mean and include the furnishing of equipment, labour and services, as per the Specifications and complete erection, testing and putting into satisfactory operation including all transportation, handling, unloading and storage at the Site as defined in the Contract.
- 1.8 '**Specifications**' shall mean the Specifications and Bidding Documents forming a part of the Contract and such other schedules and drawings as may be mutually agreed upon.
- 1.9 '**Site**' shall mean and include the land and other places on, into or through which the works and the related facilities are to be erected or installed and any adjacent land, paths, street or reservoir which may be allocated or used by TSECL or Contractor in the performance of the Contract.
- 1.10 The term '**Contract Price**' shall mean the item wise price / lump-sum price quoted by the Contractor in his bid with additions and/or deletions as may be agreed and incorporated in the Letter of Award, for the entire scope of the works.
- 1.11 The term '**Equipment Portion**' of the Contract price shall mean the ex-works value of the equipment.
- 1.12 The term '**Erection Portion**' of the Contract price shall mean the value of field activities of the works including erection, testing and putting into satisfactory operation including successful completion of performance and guarantee tests to be performed at Site by the Contractor including cost of insurances.
- 1.13 '**Manufacturer's Works**' or '**Contractor's Works**', shall mean the place of work used by the manufacturer, the Contractor, their collaborators/associate or sub-contractors for the performance of the Contract.
- 1.14 '**Inspector**' shall mean TSECL or any person nominated by TSECL from time to time, to inspect the equipment; stores or Works under the Contract and/or the duly authorized representative of TSECL.



- 1.15 **'Notification of Award of Contract'/Letter of Award'/Telex of Award'** shall mean the official notice issued by TSECL notifying the Contractor that his bid has been accepted.
- 1.16 **'Date of Contract'** shall mean the date on which Notification of Award of Contract/Letter of Award/Telex of Award has been issued.
- 1.17 **'Month'** shall mean the calendar month. 'Day or 'Days', unless herein otherwise expressly defined, shall mean calendar day or days of 24 hours each.  
A **'Week'** shall mean continuous period of seven (7) days.
- 1.18 "Writing" shall include any manuscript, type written or printed statement, under or over signature and/or seal as the case may be.
- 1.19 When the words 'Approved', 'Subject to Approval', 'Satisfactory', 'Equal to', 'Proper', 'Requested', 'As Directed', 'Where directed', 'When 'Determined by', 'Accepted', 'Permitted', or words and phrases of like importance are used, the approval, judgment, direction etc. is understood to be a function of TSECL.
- 1.20 **"Test on Completion"** shall mean such tests as prescribed in the Contract to be performed by the Contractor before the work is Taken Over by TSECL.
- 1.21 **'Start Up'** shall mean the time period required to bring the equipment covered under the Contract from an inactive condition, when construction is essentially complete, to the state ready for trial operation. The startup period shall include preliminary inspection and checkout of equipment and supporting sub-system, initial operation of the complete equipment covered under the Contract to obtain necessary pretrial operation data, perform calibration and corrective action, shut down, inspection and adjustment prior to the trial operation period.
- 1.22 **"Initial Operation"** shall mean the first integral operation of the complete equipment covered under the Contract with the sub-system and supporting equipment in service or available for service.
- 1.23 **'Trial Operation', 'Reliability Test', 'Trial Run', 'Completion Test'** shall mean the extended period of time after the startup period. During this trial operation period, the unit shall be operated over the full load range. The length of Trial Operation shall be as determined by the Engineer of TSECL unless otherwise specified elsewhere in the Contract.
- 1.24 **'Performance and Guarantee Test'** shall mean all operational checks and tests required to determine and demonstrate capacity, efficiency and operating characteristics as specified in the Contract Documents.
- 1.25 The term **'Final Acceptance/Taking Over'** shall mean written acceptance of the Works performed under the Contract by TSECL, after successful commissioning/completion of Performance and Guarantee Tests, as specified in the accompanying Technical Specification or otherwise agreed in the Contract.
- 1.26 **" Commercial Operation"** shall mean the Conditions of Operation in which the complete equipment covered under the Contract is officially declared by TSECL to be available for continuous operation at different loads up to and including rated capacity. Such declaration by TSECL, however, shall not relieve or prejudice the Contractor of any of his obligations under the Contract.
- 1.27 **'Guarantee period'/'Maintenance Period'** shall mean the period during which the Contractor shall remain liable for repair or replacement of any defective part of the works performed under the contract.
- 1.28 **'Latent Defects'** shall mean such defects caused by faulty designs, material or workmanship which cannot be detected during inspection, testing etc, based on the technology available for carrying out such tests.





**1.29** 'Drawings', 'Plans' shall mean all:

- a) Drawing furnished by TSECL as a basis for Bid Proposals.
- b) Supplementary drawings furnished by TSECL to clarify and define in greater detail the intent of the Contract.
- c) Drawings submitted by the Contractor with his Bid provided such drawings are acceptable to TSECL.
- d) Drawings furnished by TSECL to the Contractor during the progress of the Work; and
- e) Engineering data and drawings submitted by the Contractor during the progress of the Work provided such drawings are acceptable to the Engineer in charge of the work.

**1.30** "Codes" shall mean the following including the latest amendments and / or replacement, if any:

- a) A.S.M.E. Test Codes.
- b) A.I.E.E. Test Codes.
- c) American Society of Testing Materials Codes.
- d) Standards of the Indian Standards Institutions.
- e) I.E.E. standards.
- f) I.E.C. standards.
- g) Other Internationally approved standards and / or Rules and **Regulations touching the subject matter of the Contract.**

**1.31** Words imparting 'Person' shall include firms, companies, corporation and association or bodies of individuals.

**1.32** Terms and expressions not herein defined shall have the same meaning as are assigned to them in the **Indian Sale of Goods Act (1930)**, failing that in the **Indian Contract Act (1872)** and failing that in the **General Clauses Act (1897)** including amendments thereof if any.

**1.33** In addition to the above the following definitions shall also apply.

- a) 'All equipment and materials' to be supplied shall also mean 'Goods'.
- b) 'Constructed' shall also mean 'erected and installed'
- c) 'Contract Performance Guarantee shall also mean 'Contract Performance Security'

## **2.0 APPLICATION**

These General Conditions shall apply to the extent that they are not **superseded by provisions in other parts of the Contract.**

## **3.0 STANDARDS**

The Goods supplied under this Contract shall conform to the standards mentioned in the Various Technical Specifications and when no applicable standard is mentioned to the authoritative standard appropriate to the Goods and such standards shall be the latest issued by the concerned institution.

## **4.0 LANGUAGE AND MEASURES**

All documents pertaining to the Contract including specification, Schedules, notices, correspondence, operating and maintenance instructions, drawings or any other writing shall



be written in English language. The Metric System of measurement shall be used exclusively in the Contract.

## **5.0 CONTRACT DOCUMENTS**

5.1 The term “Contract Documents” shall mean and include the following which shall be deemed to form an integral part of the Contract:

- a) Invitation of Bid including letter forwarding the Bidding Documents, Instructions to Bidders, General Terms and Conditions of Contract, Erection Conditions of Contract and all other documents included under the Special Conditions of Contract and various other sections.
- b) Specifications of the equipment to be furnished and erected under the Contract as brought out in the accompanying Technical Specification.
- c) Contractor’s Bid proposal and the documents attached there-to including the letter of clarifications thereto between the Contractor and TSECL prior to the Award of Contract.
- d) All the materials, literature, data and information of any sort given by the Contractor along with his bid, subject to the approval of TSECL.
- e) Letter of Award and any agreed variations of the conditions of the documents and special terms and conditions of contract if any.

## **6.0 USE OF THE CONTRACT DOCUMENTS AND INFORMATION**

The Contractor shall not communicate or use in advertising, publicity, sales releases or in any other medium, photographs or other reproduction of the Works under this contract, or descriptions of the site, dimensions, quantity, quality, or other information, concerning the Works unless prior written permission has been obtained from TSECL.

## **7.0 JURISDICTION OF CONTRACT**

The laws applicable to the Contract shall be the laws in force in India. The Courts of **Agartala** shall have exclusive jurisdiction in all matters arising **under this Contract**.

## **8.0 MANNER OF EXECUTION OF CONTRACT**

8.1 The contractor should attend the concerned office of TSECL within 15(fifteen) days from the date of issue of the Letter of Award to the Contractor for signing the contract agreement.

The Contractor shall provide for signing of the Contract, Performance Guarantee, appropriate power of attorney and other requisite materials.

8.2 The Agreement shall be signed in two originals and the Contractor shall be provided with one signed original and the rest shall be retained by TSECL.

8.3 The Contractor shall provide free of cost to TSECL all the engineering data, drawings, and descriptive materials submitted with the Bid, in at least six (6) copies to form a part of the contract immediately after issue of Letter of Award.

8.4 Subsequent to signing of the Contract, the Contractor, at his own cost, shall provide TSECL with at least five (5) true copies of Agreement and one soft copy including 3(three) hard copies of the approved drawings within fifteen (15) days after the signing of the Contract.



## 9.0 ENFORCEMENT OF TERMS

9.1 The failure of either party to enforce at any time any of the provisions of this Contract or any rights in respect thereto or to exercise any option therein provided, shall in no way be construed to be a waiver of such provisions, rights or options or in any way to affect the validity of the Contract. The exercise by either party of any of its rights herein shall not prejudice either party from exercising the same or any other right it may have under the **Contract**.

## 10.0 COMPLETION OF CONTRACT

10.1 Unless otherwise terminated under the provisions of any other relevant clause, this Contract shall be deemed to have been completed on the date stipulated in the NIT.

### GUARANTEE & LIABILITIES

## 11.0 TIME – THE ESSENCE OF CONTRACT

11.1 The time and the date of completion of the Contract as stipulated in the Contract by TSECL without or with modifications, if any, and so incorporated in the Letter of Award, shall be deemed to be the essence of the Contract. The Contractor shall so organize his resources and perform his Work as to complete it not later than the date agreed to.

11.2 The Contractor shall submit a detailed **BAR CHART / PERT NETWORK** consisting of adequate number of activities covering various key phases of the Work such as design, procurement, manufacturing, shipment and field erection activities within fifteen (15) days of the date of Notice of Award of Contract. This Bar Chart shall also indicate the interface facilities to be provided by TSECL and the dates by which such facilities are needed. The Contractor shall discuss with TSECL for finalization and approval of the Bar Chart by TSECL. The agreed Bar Chart shall form part of the contract documents. During the performance of the Contract, if in the opinion of the owner's Engineer in charge of the work, proper progress is not maintained, suitable changes shall be made in the Contractor's operations to ensure proper progress without any cost implication to TSECL. The interface facilities to be provided by TSECL in accordance with the agreed Bar Chart shall also be reviewed while reviewing the progress of the Contractor.

11.3 Based on the agreed Bar Chart fortnightly reports shall be submitted by the Contractor as directed by the owner's Engineer in charge of the work.

11.4 Subsequent to the finalization of the Bar Chart, the Contractor shall make available to the owner's Engineer in charge of the work a detailed manufacturing programme in line with the agreed Contract Bar Chart. Such manufacturing programme shall be reviewed, updated and submitted to the owner's Engineer in charge of the work once in every month thereafter.

11.5 The above Bar Charts/manufacturing programme shall be compatible with TSECL computer environment and furnished to TSECL on such media as may be desired by TSECL.

## 12.0 EFFECTIVENESS OF CONTRACT

The Contract shall be considered as having come into force from the date of the Notification of Award, unless otherwise provided in the Notification of Award.

## 13.0 LIQUIDATED DAMAGES

13.1



In case the materials are not delivered within the time stipulated in the order or delay in achieving the milestones defined under Section II, clause 14, time schedule or in case of in-performed services, the supplier/contractor shall have to pay at the discretion of the competent authority of purchaser, the liquidated damages to be determined by the purchaser as 1 % of the delivered price of the delayed goods or in-performed work/ services for per week or part thereof of delay until actual delivery or performance subject to a maximum deduction of 5% of the delayed goods/work /services price. Due consideration may be given in the levy of damages for reasons absolutely beyond the control of the supplier for which documentary evidence shall be provided to the satisfaction of the competent delayed supplies

#### **14.0 GUARANTEE**

- 14.1 The Contractor shall warrant that the equipment shall be new, unused and in accordance with the contract documents and free from defects in material and workmanship for a period of Thirty (30) calendar months commencing immediately upon the satisfactory commissioning. The Contractor's liability shall be limited to the replacement of any defective parts in the equipment of his own manufacture or those of his sub-contractors under normal use and arising solely from faulty design, materials and/or workmanship provided always that such defective parts are repairable at the site and are not in the meantime essential in the commercial use of the equipment. Such replaced/defective parts shall be returned to the Contractor unless otherwise arranged. No repairs or replacement shall normally be carried out by owner's Engineer in charge of the work when the equipment is under the supervision of the Contractor's supervisory engineer.
- 14.2 In the event of any emergency, where in the judgment of the owner's Engineer in Charge of work, delay would cause serious loss or damages, repairs or adjustment may be made by him or a third party chosen by him without advance notice to the Contractor and the cost of such work shall be paid by the Contractor. In the event such action is taken by the Engineer in Charge of work, the Contractor shall be notified promptly and he shall assist wherever possible in making necessary corrections. This shall not relieve the Contractor of his liabilities under the terms and conditions of the Contract.
- 14.3 If it becomes necessary for the Contractor to replace or renew any defective portions of the Works, the provision of this clause shall apply to portion of the Works so replaced or renewed until the expiry of Twelve (12) months from the date of such replacement or renewal. If any defects are not remedied within a reasonable time, the Engineer in Charge of work may proceed to do the work at the Contractor's risk and cost, but without prejudice to any other rights which TSECL may have against the Contractor in respect of such defects.
- 14.4 The repaired or new parts shall be furnished and erected free of cost by the Contractor. If any repair is carried out on his behalf at the site, the Contractor shall bear the cost of such repairs.
- 14.5 The cost of any special or general overhaul rendered necessary during the maintenance period due to defects in the equipment or defective work carried out by the Contractor shall be borne by the Contractor.
- 14.6 The acceptance of the equipment by the Engineer in Charge of work shall in no way relieve the Contractor of his obligation under this clause.
- 14.7 In the case of those defective parts, which are not repairable at site but are essential for the commercial operation of the equipment, the Contractor and the Owner's Engineer in Charge



of work shall mutually agree to a programme of replacement or renewal, which shall minimize interruption to the maximum extent in the operation of the equipment.

- 14.8 At the end of the guarantee period, the Contractor's liability ceases except for latent defects. For latent defects, the Contractor's liability as mentioned in clause nos. 14.1 through 14.7 above shall remain till the end of 5 years from the date of commissioning.

In respect of goods supplied by sub-contractors to the Contractor, where a longer guarantee (more than 12 months) is provided by such sub-contractor, TSECL shall be entitled to the benefits of such longer guarantee.

- 14.9 The provisions contained in this clause shall not be applicable:

- a) If TSECL has not used the equipment according to the generally approved industrial practice and in accordance with the conditions of operations specified and in accordance with operating manuals, if any.
- b) In cases of normal wear and tear of the parts to be specifically mentioned by the Contractor in the offer.

## **15.0 TAXES, PERMITS & LICENCES**

The Contractor shall be liable and pay all non-Indian taxes, duties, levies lawfully assessed against TSECL or the Contractor in pursuance of the Contract. In addition, the Contractor shall be responsible for payment of all Indian duties, levies and taxes lawfully assessed against this contract.

## **16.0 REPLACEMENT OF DEFECTIVE PARTS AND MATERIALS**

- 16.1 If during the performance of the Contract, owner's Engineer in charge of the work shall decide and inform in writing to the Contractor that the Contractor has manufactured any equipment, material or part of equipment unsound and imperfect or has furnished any equipment inferior to the quality specified, the Contractor on receiving details of such defects or deficiencies shall at his own expense within Seven (7) days of his receiving the notice, or otherwise, within such time as may be reasonably necessary for making it good, proceed to alter, reconstruct or remove such works and furnish fresh equipment/materials up to the standards of the specifications. In case, the Contractor fails to do so, the Owner's Engineer in charge of the work may on giving the Contractor Seven (7) days' notice in writing of his intentions to do so, proceed to remove the portion of the works so complained of and at the cost of the Contractor perform all such work or furnish all such equipment/materials.

- 16.2 The Contractor's full and extreme liability under this clause shall be satisfied by the payment to TSECL of the extra cost, of such replacement procured including erection as provided for in the Contract, such extra cost being the ascertained difference between the price paid by TSECL for such replacements and the Contract Price by portion for such defective equipment/materials/works and repayments of any sum paid by TSECL to the Contractor in respect of such defective equipment/material. Should TSECL not so replace the defective equipment/materials, the Contractor's extreme liability under this clause shall be limited to repayment of all sums paid by TSECL under the Contract for such defective equipment/materials.

## **17.0 PATENT RIGHTS AND ROYALTIES**

Royalties and fees for patents covering materials, articles, apparatus, devices, equipment or processes used in the Works shall be deemed to have been included in the Contract Price. The Contractor shall satisfy all demands that may be made at any time for such royalties or fees and he alone shall be liable for any damages or claims for patent infringements and shall



keep TSECL indemnified in that regard. The Contractor shall, at his own cost and expense, defend all suits or proceedings that may be instituted for alleged infringement of any patents involved in the Works, and, in case of an award of damages, the Contractor shall pay for such award. In the event of any suit or other proceedings instituted against TSECL, the same shall be defended at the cost and expense of the Contractor who shall also satisfy/comply with any decree, order or award made against TSECL. But it shall be understood that no such machine, plant, work, material or thing has been used by TSECL for any purpose or any manner other than that for which they have been furnished and installed by the Contractor and specified under these specifications. Final payment to the Contractor by TSECL shall not be made while any such suit or claim remains unsettled. In the event any apparatus or equipment, or any part thereof furnished by the Contractor, is in such suit or proceedings held to constitute infringement, and its use is enjoined, the Contractor shall at his option and at his own expense, either procure for TSECL, the right to continue the use of said apparatus, equipment or part thereof, replace it with non-infringing apparatus or equipment or modify it, so it becomes non-infringing.

## **18.0 DEFENCE OF SUITS**

If any action in court is brought against TSECL for the failure, omission or neglect on the part of the Contractor to perform any acts, matters, or things under the Contract, or for damage or injury caused by the alleged omission or negligence on the part of the Contractor, his agents, representatives or his Sub-Contractors, or in connection with any claim based on lawful demands of Sub-Contractors, workmen, suppliers or employees, the Contractor shall in all such cases indemnify and keep TSECL, from all losses, damages, expenses or **decrees arising of such action.**

## **19.0 LIMITATION OF LIABILITIES**

The final payment by TSECL in pursuance of the Contract shall mean the release of the Contractor from all his liabilities under the Contract. Such final payment shall be made only at the end of the Guarantee/Warranty Period, and till such time as the contractual liabilities and responsibilities of the Contractor, shall prevail. All other payments made under the Contract shall be treated as on-account payments.

## **20.0 POWER TO VARY OR OMIT WORK**

20.1 No alterations, amendments, omissions, suspensions or variations of the Works (hereinafter referred to as 'variation') under the Contract as detailed in the Contract Documents, shall be made by the Contractor except as directed in writing by owner's Engineer in charge of the work, but he shall have full powers subject to the provisions hereinafter contained, from time to time during the execution of the Contract, by notice in writing to instruct the Contractor to make such variation without prejudice to the Contract. The Contractor shall carry out such variation and be bound by the same conditions as far as applicable as though the said variations occurred in the Contract Documents. If any suggested variations would, in the opinion of the Contractor, if carried out, prevent him from fulfilling any of his obligations or guarantees under the Contract, he shall notify the Engineer thereof in writing and the Engineer shall decide forthwith whether or not, the same shall be carried out and if the Engineer confirm his instructions, the Contractor's obligations and guarantees shall be modified to such an extent as may be mutually agreed. Any agreed difference in cost occasioned by any such variation shall be added to or deduced from the Contract Price as the case may be.

20.2 In the event of the Engineer requiring any variation, a reasonable and proper notice shall be given to the Contractor to enable him to work his arrangement accordingly, and in cases where goods or materials are already prepared or any design, drawings or pattern made or





work done requires to be altered, a reasonable and agreed sum in respect thereof shall be paid to the Contractor.

20.3 In any case in which the Contractor has received instructions from the Engineering charge of the work as to the requirement of carrying out the alterations or additional or substituted work which either then or later on, shall in the opinion of the Contractor, involve a claim for additional payment, the Contractor shall immediately and in no case later than Thirty (30) days, after receipt of the instructions aforesaid and before carrying out the instructions, advise the Owner's Engineer in charge of the work to that effect. But the Owner's Engineer in charge of the work shall not become liable for the payment of any charges in respect of any such variations, unless the instructions for the performance of the same shall be confirmed in writing by the Engineer in charge of the work.

20.4 If any variation in the Works results in reduction of Contract Price, the parties shall agree, in writing, to the extent of any change in the price, before the Contractor proceeds with the change.

20.5 In all the above cases, in the event of a disagreement as to the reasonableness of the said sum, the decision of owner's Engineer in charge of the work shall prevail.

20.6 Notwithstanding anything stated above in this clause, owner's Engineer in charge of the work shall have the full power to instruct the Contractor, in writing, during the execution of the Contract to vary the quantities of the items or groups of items in accordance with the provisions of clause entitled 'Change of Quantity in Section – III'. The Contractor shall carry out such variations and be bound by the same conditions as though the said variations occurred in the Contract Documents.

## 21.0 **ASSIGNMENT AND SUB-LETTING OF CONTRACT**

21.1 The Contractor may, after informing owner's Engineer in charge of the work and getting his written approval, assign or sub-let the Contract or any part thereof other than supply of main equipment's and any part of the plant for which makes are identified in the Contract. Suppliers of the equipment not identified in the Contract or any change in the identified suppliers shall be subjected to approval by the owner's Engineer in charge of the work. The experience list of equipment vendors under consideration by the Contractor for this Contract shall be furnished to the owner's Engineer in charge of the work for approval, prior to procurement of all such items/equipment. Such assignment/sub-letting shall not relieve the Contractor of any obligation, duty or responsibility under the Contract. Any assignment as above, without prior written approval of the owner's Engineer in charge of the work, shall be void.

21.2 For components/equipment procured by the Contractor for the purposes of the Contract, after obtaining the written approval of TSECL, the Contractor's purchase specifications and inquiries shall call for quality plan to be submitted by the suppliers along with their proposals. The quality plans called for from the Vendors shall set out, during the various stages of manufacture and installation, the quality practices and procedures followed by the Vendors quality control organization, the relevant reference document/standard used, acceptance level, inspection documentation raised, etc. Such quality plans of the successful vendors shall be discussed and finalized in consultation with the owner's Engineer in charge of the work and shall form part of the purchase order/contract between the Contractor and the Vendor. Within three weeks of the release of the purchase orders/contracts for such bought out items/components, a copy of the same without price details but together with detailed purchase specifications, quality plans and delivery conditions shall be furnished to the owner's Engineer in charge of the work by the Contractor.



## 22.0 CHANGE OF QUANTITY

22.1 During the execution of the Contract, TSECL reserves the right to increase or decrease the quantities of items under the Contract but without any change in unit price or other terms & conditions. Such variations shall not be subjected to any limitation for the individual items but the total variations in all such items including items not covered under the Contract shall be limited to  $\pm 25\%$  of contract value.

22.2 The Contract price shall accordingly be adjusted based on the unit rates available in the Contract for the change in quantities as above. The base unit rates, as identified in the Contract shall however remain constant during the currency of the Contract, except as provided for in clause 32.0 below. In case, the unit rates are not available in the contract, the same shall be worked out as below: -

- i) If the rates for the additional, altered or substituted work are specified in the contract, the contractor is bound to carry the additional, altered or substituted work at the same rates as are specified in the contract.
- ii) If the rates for the additional, altered or substituted work are not specifically provided in the contract, the rates will be derived from a similar class of work as are specified in the contract.
- iii) If the rates for the additional, altered or substituted work includes any work for which no rate is specified in the contract / cannot be derived from the similar class of work in the contract, then such work shall be carried out at the rates which will be determined on the basis of current schedule of rate of TSECL above minus / plus the percentage which the total contract amount bears to the estimated cost put to tender. Provided always if the rate for particular part or parts of the item is not available in the schedule of rates the rate of such part or parts will be determined by TSECL of the work on the basis of the prevailing market rate when the work was done.
- iv) If the rates for the additional, altered or substituted work cannot be determined in the manner specified in sub-clause i, ii & iii above, then the contractor shall within 7(Seven) days of receipt of order to carry out the order, inform the owner's Engineer in charge of the work of rate which it is his intention to charge for such class of work, supported by analysis of rate or rates claimed, and TSECL shall determine the rate or rates claimed with mutual settlement with the contractor.
- v) The deviation limit referred to above is the net effect (algebraically sum) of all additions and deductions ordered.
- vi) Time for the completion for the work shall be extended in the proportion that the altered, additional or substituted work bears to the original contract of the work and the certificate of the owner's Engineer in charge of the **work shall be conclusive for approval of the time extension by TSECL.**

## 23.0 PAKCING, FORWARDING AND SHIPMENT

23.1 The Contractor, wherever applicable, shall after proper painting, pack and crate all equipment in such a manner as to protect them from deterioration and damage during rail and road transportation to the site and storage at the site till the time of erection. The Contractor shall be held responsible for all damages due to improper package.

23.2 The Contractor shall notify the owner's Engineer in charge of the work of the date of each shipment from his works, and the expected date of arrival at the site.



23.3 The Contractor shall also give all shipping information concerning the weight, size and content of each packing including any other information the owner's Engineer in charge of the work may require.

23.4 The Contractor shall prepare detailed packing list of all packages and containers, bundles and loose materials forming each and every consignment dispatch to Site.

The Contractor shall further be responsible for making all necessary arrangements for loading, unloading and other handling, right from his works up to the Site and also till the equipment is erected, tested and commissioned. He shall be solely responsible for proper storage and safe custody of all equipment.

#### 24.0 **CO-OPERATION WITH OTHER CONTRACTORS AND CONSULTING ENGINEERS**

The Contractor shall agree to cooperate with the TSECL's Consulting Engineers and freely exchange with them such technical information, as is necessary to obtain the most efficient and economical design and to avoid unnecessary duplication of efforts. The owner's Engineer in charge of the work shall be provided with three copies of all correspondence addressed by the Contractor to the consulting Engineers of TSECL in respect of such exchange of technical information.

#### 25.0 **NO WAIVER OF RIGHTS**

Neither the inspection by TSECL nor any order by TSECL for payment of money or any payment for or acceptance of, the whole or any part of the Works by the owner's Engineer in charge of the work, nor any extension of time, nor any possession taken by the owner's Engineer in charge of the work shall operate as a waiver of any provision of the Contract, or of any power herein reserved to TSECL or any right to damages herein provided nor shall any waiver of any breach in the Contract be held to be a waiver of any other or subsequent breach.

#### 26.0 **CERTIFICATE NOT TO AFFECT RIGHT OF TSECL AND LIABILITY OF CONTRACTOR.**

No interim payment certificate of the owner's Engineer in charge of the work, nor any sum paid on account by TSECL, nor any extension of time for execution of the Works granted by TSECL shall affect or prejudice the rights of TSECL against the Contractor or relieve the Contractor of his obligation for the due performance of the Contractor, or be interpreted as approval of the Works done or of the equipment furnished and no certificate shall create liability for TSECL to pay for alterations, amendments, variations or additional works not ordered, in writing, by the owner's Engineer in charge of the work or discharge the liability of the Contractor for the payment of damages whether due, ascertained or certified or not or any sum against the payment of which he is bound to indemnify TSECL, nor shall any such certificate nor the acceptance by him of any sum paid on account or otherwise affect or prejudice the rights of TSECL against the Contractor.

#### 27.0 **INSPECTION AND TESTING OF EQUIPMENTS / MATERIALS**

27.1 **All equipment's / materials shall be dispatched by the contractor only after issuance of 'Materials Inspection Clearance Certificate (MICC)' by the inspecting officer / team of TSECL , Waiver of inspection may be done by TSECL special circumstances with deduction of inspection cost @ Rs. 10,000.00/ per Lot for which inspection to be waived. In that case bidder should submit the routine test certificate of manufacturers which shall be on the basis for acceptance of such materials by TSECL. No such materials will be accepted without test certificate.**



27.2 After manufacturing or at the stage of dispatch of equipment's / materials the contractor shall give intimation to the owner's Engineer in charge of the work for conducting inspection of equipment's / materials at manufacture's works or at recognized testing laboratories to be arranged by the contractor. **The intimation shall be made at least 15(fifteen) days before the equipment's / materials become ready for dispatch.**

27.3. Testing of equipment's / materials as specified above shall be conducted at the risk and cost of the contractor. **The contractor shall also bear expenses of inspection cost of the inspecting officer(ERDA) / team of TSECL.**

## 28.0 PROGRESS REPORTS AND PHOTOGRAPHS

During the various stages of the Work in the pursuance of the Contract, the Contractor shall at his own cost submit periodic progress reports as may be reasonably required by the owner's Engineer in charge of the work with such materials as, charts, Bar Charts, photographs, test certificates, etc. Such progress reports shall be in the form and size as may be required by the owner's Engineer in charge of the work and shall be submitted in at least Three (3) copies.

## 29.0 EXTENSION OF TIME

29.1 TSECL may consider granting **time extension** for completion of the work if it is felt absolutely essential on fulfillment of following conditions by the Contractor: -

a) The contractor must apply to the Engineer-In-charge in writing for extension of time so required justifying the necessity.

b) Such application must state **the grounds** which hindered the contractor in the execution of the work within the time as stipulated in the contract document.

c) Such application must be made within 30 days of the date on which such hindrance had arisen.

d) The **Engineer-in charge** must be of the opinion that the grounds shown for the extension of time are reasonable and without extension of such time completion of the work is practically impossible.

29.2 **The Engineer-In- Charge** will have full powers, but the orders on the application of the Contractor accepted by the Authorities higher than the Engineer-In-Charge shall be issued by him only after written approval from the concerned authority higher than Engineer-In-Charge.

29.3 The opinion of the **Engineer- in- charge**, whether the grounds shown for the **time are or are not reasonable, is final. If the Engineer- in- charge is of the** opinion that the grounds shown by the supplier/ contractor are not reasonable and declines to grant extension to time, the supplier/contractor cannot challenge.

## 30.0 TAKING OVER

Upon successful completion of all the tests to be performed at Site on equipment furnished and erected by the Contractor, the owner's Engineer in charge of the work shall issue to the Contractor a **Taking over Certificate** as a proof of the final acceptance of the equipment. Such certificate shall not unreasonably be withheld.

## CONTRACT SECURITY AND PAYMENTS

### 31.0 CONTRACT PERFORMANCE GUARANTEE



The Contractor shall furnish **Contract Performance Guarantee** as specified in Clause 6.0 of Section - I for the proper fulfillment of the Contract within Fifteen (15) days of **“Notice of Award of Contract.”**

**32.0 CONTRACT PRICE ADJUSTMENT**

**32.1 All prices / price components of the contract shall remain firm and no adjustment of price, whatsoever, shall be applicable during the currency of contract**

**33.0 PAYMENT**

**33.1** For tenderer(s) payment will be made through RTGS/Banker Cheque within 60 (sixty days) of submission of invoice in complete shape along with required documents / certificates.

Payment will be made in accordance with Payment Schedule in mentioned herein after.

Any terms of advance payments i.e. payments against dispatch documents/Bank documents will not be acceptable.

In no circumstances, claim of interest on payment shall be entertained.

The final payment will be made after commissioning of all works and on completion of **Warranty / Guaranty Period** including fulfillment by the Contractor of all his liabilities under the Contract.

**33.2 Currency of Payment**

All payments under the Contract shall be in Indian Rupees only.

**33.3 Due Dates for Payments**

TSECL will make progressive payment as and when the payment is due as per the terms of payment set forth as herein after.

**34.0 Mode of Payment**

**34.1** Payment due on supply materials / services shall be made by the owner’s Engineer in charge of the work through RTGS

**34.2 Payment Schedule**

The terms of payments for various activities under the contract are as under.

**Payment Schedule**

The terms of payments for price of all equipment / materials and erection are detailed herein after.

**A) For supply of Equipment / materials**

- i) 40% of the cost of equipment / materials after:
  - a. Acknowledgement of Letter of Award.
  - b. Submission of contract performance guarantee as per **clause 8.0 (Section – I)**.
  - c. Submission of a detailed Bar Chart based on the work schedule stipulated in the Bid document and its approval by TSECL.



- d. Signing of contract agreement.
- e. On production of dispatch documents including the material inspection clearance certificate (MICC) issued by the inspecting officer / team of TSECL.
- f. On receipt of materials at site.
- i) Balance 40% of the cost of equipment / materials after successful erection at site.
- j) Balance 20% of the cost of equipment / materials after successful commissioning.

**B) For the Erection Component**

- i) 90% of the erection component after
    - a. On establishing his office at site preparatory to mobilization of his erection establishment including posting of site engineer.
    - b. On successful erection of equipments / materials as per direction of the owner's Engineer in charge of the work.
  - ii) Balance 10% after successful commissioning.
- i) Progressive bill value for erection component shall not be less than **Rs.2.0 lakh**.

All further payments under the Contract shall be made as stipulated in the Contract document after signing the Contract Agreement. The adjusted contract price as per relevant clauses of the contract document shall be made by TSECL or adjusted from the progressive bill of the contractor on submission of price adjustment invoices with supporting documents by the contractor and on final acceptance by TSECL.

**34..3 Inland Transportation & Insurance**

Inland transportation (including port handling) and inland insurance charges shall be borne by the contractor and TSECL in no way shall be liable for the inland transportation and insurance charges.

**35.0 DEDUCTION FROM CONTRACT PRICE**

All costs, damages or expenses which TSECL may have paid, for which under the Contract, the Contractor is liable, will be deducted from the progressive bill of the contractor.

**36.0 SPARES**

36.1 All the spares for the equipment under the Contract will, strictly, conform to the specification and documents and will be identical to the corresponding main equipment / components supplied under the Contract and shall be fully interchangeable.

36.2 All the mandatory spares covered under the Contract shall be produced along with the main equipment as a continuous operation and the delivery of the spares will be affected along with the main equipment in a phased manner and the delivery would be completed by the respective dates for the various categories of equipment as per the agreed Bar chart. In case of recommended spares, the above will be applicable provided the order for the recommended spares has been placed with the Contractor prior to commencement of manufacture of the main equipment





- 36.3 The quality plan and the inspection requirement finalized for the main equipment will also be applicable for the corresponding spares.
- 36.4 The Contractor will provide TSECL with the manufacturing drawings, catalogues, assembly drawings and any other documents required by TSECL so as to enable the Owner to identify the recommended spares. Such details will be furnished to TSECL as soon as they are prepared but, in any case, not later than six months prior to commencement of manufacture of the corresponding main equipment.
- 36.5 The Contractor will provide TSECL with all the addresses and particulars of his sub-suppliers while placing the order on vendors for items/components/equipment covered under the Contract and will further ensure with his vendors that TSECL, if so desires, will have the right to place order (s) for spares directly on them on mutually agreed terms based on offers of such vendors.

### 36.6 WARRANTIES FOR SPARES

The Contractor shall warrant that all spares supplied will be new and in accordance with Contract Documents and will be free from defects in design, materials and workmanship and shall further guarantee as under:

- 36.6.1 for 3 years operational spares (both mandatory and recommended)
- a. For any item of spares ordered or to be ordered by TSECL for 3 years operational requirement of the plant which is manufactured as a continuous operation together with the corresponding main equipment/component, the warranty will be 12 months from the scheduled date of commercial operation of the last unit of main equipment under the Contract. In case of any failure in the original component/equipment due to faulty designs, materials and workmanship, the corresponding spare parts, if any, supplied will be replaced without any extra cost to TSECL unless a joint examination and analysis by TSECL and the Contractor of such spare parts prove that the defect found in the original part that failed, can safely be assumed not to be present in spare parts. Such replaced spare parts will have the same warranty as applicable to the replacement made for the defective original part/component provided that such replacement for the original equipment and the spare replaced are again manufactured together. The discarded spare parts will become the property of the Contractor as soon as they have been replaced by the Contractor.
- b. For the item of spares ordered/to be ordered by TSECL for 3 years operational requirement of the equipment, which with the written approval of the Owner, are not manufactured as a continuous operation together with the manufacture of the corresponding main equipment/component, will be warranted for 6000 hrs. of trouble-free operation, if used within a period of 18 months (reckoned from the date of delivery at Site). However, if such spare parts are put to use after 18 months of the delivery at site, then the guarantee of such spares will stand valid till the expiry of 36 months from the scheduled date of the completion of commissioning of the last unit of equipment or 6000 hrs. of trouble-free operation after such spares are put in service, whichever is earlier.
- c. For long Term Requirement.
- For items of spares that may be ordered by TSECL to cover requirements beyond 3 years of initial operation of the plant, the warranty will be till the expiry of 6000 hrs. of trouble-free operation if used within a period of 18 months from the date of delivery at Site. For items of spares that may be used after 18 months from the date of delivery at Site, the warranty period will be 12 months from the date they are put to use or 6000 hrs. of trouble-free operation, whichever is earlier.



- 36.6.2 The warranty of spares that are not used within 18 months from the respective dates of the delivery at Site covered in Para (b) & (c) above will, however, be subject to the condition that all such spares have been stored/maintained/preserved in accordance with Contractor's standard recommended practice, if any, and the same have been furnished to TSECL.
- 36.6.3 To enable TSECL to finalize the requirement of recommended spares which are ordered subsequent to placement of order for main equipment in addition to necessary technical details, catalogue and such other information brought-out here-in-above, the Contractor will also provide a justification in support of reasonableness of the quoted prices of spares which will, inter-alia, include documentary evidence that the prices quoted by the Contractor are not higher than those charged by them from other customers in the same period.
- 36.6.4 In addition to the spares recommended by the Contractor, if TSECL further identifies certain particular items of spares, the Contractor will submit the prices and delivery quotations for such spares within 30 days of receipt of such request with validity period for 6 months for consideration of placement of order for additional spares, if TSECL so desires
- 36.6.5 The Contractor shall guarantee the long-term availability of spares to TSECL for the full life of the equipment covered under the Contract. The Contractor shall guarantee that before going out of production of spare parts of the equipment, he shall give at least twelve (12) months advance notice so that the latter may order his bulk requirement of spares, if he so desires. The same provision will also be applicable to Sub-Contractor of any spares by the Contractor or his Sub-Contractors. Further, in case of discontinuance of manufacture of any spares by the Contractor or his Sub-Contractors, the Contractor will provide TSECL, two years in advance, full manufacturing drawings, material specifications and technical information required by TSECL for the purpose of manufacture of such items.
- 36.6.6 Further in case of discontinuance of supply of spares by the Contractor or his Sub-contractors, the Contractor will provide TSECL with full information for replacement of such spares with other equivalent makes, if so required by TSECL.
- 36.6.7 The prices of all future requirements of items of spares beyond 3 years operational requirement will be derived from the corresponding ex-works price at which the order for such spares have been placed by TSECL as part of mandatory spares or recommended spares. Ex-works order price of future spares shall be computed in accordance with the price adjustment provisions covered under the main Contract excepting that 'the base indices will be counted from the scheduled date of successful completion of trial operation of the last equipment under the main project and there will be no ceiling on the amount of narration in the prices. The above option for procuring future long term requirement of spares by TSECL shall remain valid for a period of 5 years from successful completion of commissioning of the last unit of equipment.
- 36.6.8 The Contractor will indicate in advance the delivery period of the items of spares, which TSECL may procure in accordance with above Sub-clause. In case of emergency requirements of spares, the Contractor would make every effort to expedite the manufacture and delivery of such spares on the basis of mutually agreed time schedule.
- 36.6.9 In case the Contractor fails to supply the mandatory, recommended or long-term spares in accordance with the terms stipulated above, TSECL shall be entitled to purchase the same from alternate sources at the risk and the cost of the Contractor and recover from the Contractor, the excess amount paid by TSECL over the rates worked out on the above basis. In the event of such risk purchase by TSECL, the purchases will be as per the works and procurement policy of TSECL prevalent at the time of such purchases and at his option, may include a representative of the Contractor in finalizing the purchases.



36.6.10 It is expressly understood that the final settlement between the parties in terms of the relevant clauses of the Bidding Documents shall not relieve the Contractor of any his obligations under the provision of long-term availability of spares unless otherwise discharged in writing by TSECL.

### 37.0 TRANSFER OF THE TITLE

37.1 This Transfer of Title of equipment's / materials shall not be construed to mean the acceptance and the consequent "Taking Over" of equipment and materials. The Contractor shall continue to be responsible for the quality and performance of such equipment and materials and for their compliance with the specifications until "**Taking Over**" and the fulfillment of guarantee provisions of this Contract.

37.2 This Transfer of Title shall not relieve the Contractor from the responsibility for all **risks of loss or damage** to the equipment and materials as specified under the clause entitled "Insurance" of this Section.

### 38.0 INSURANCE

The Contractor at his cost shall arrange, secure and maintain all insurance as may be pertinent to the Works and obligatory in terms of law to protect his interest and interests of TSECL against all perils detailed herein. The form and the limit of such insurance as defined herein together with the under-writer in each case shall be acceptable to TSECL. However, irrespective of such acceptance, the responsibility to maintain adequate insurance coverage at all times during the period of Contract shall be of the Contractor alone. The Contractor's failure in this regard shall not relieve him of any of his contractual responsibilities and obligations. The insurance covers to be taken by the Contractor shall be in a joint name of TSECL and the Contractor. The Contractor shall, however, be authorized to deal directly with Insurance Company or Companies and shall be responsible in regard to maintenance of all insurance covers. Further the insurance should be in freely convertible currency.

38.2 Any loss or damage to the equipment during handling, transportation, storage, erection, putting into satisfactory operation and all activities to be performed till the successful completion of commissioning of the equipment shall be to the account of the Contractor. The Contractor shall be responsible for preference of all claims and make good the damages or loss by way of repairs and/or replacement of the equipment, damaged or lost. The transfer of title shall not in any way relieve the Contractor of the above responsibilities during the period of Contract. The Contractor shall provide TSECL with copy of all insurance policies and documents taken out by him in pursuance of the Contract. Such copies of documents shall be submitted to TSECL immediately after such insurance coverage. The Contractor shall also inform TSECL in writing at least Sixty (60) Days in advance regarding the expiry/cancellation and/or change in any of such documents and ensure re-validation, renewal etc., as may be necessary well in time.

38.3 The perils required to be covered under the insurance shall include, but not be limited to fire and allied risks, miscellaneous accidents (erection risks) workman compensation risks, loss or damage in transit, theft, pilferage, riot, strikes, social unrest and malicious damages, civil commotion, weather conditions, accidents of all kinds, etc. The scope of such insurance shall be adequate to cover the replacement/reinstatement cost of the equipment for all risks up to and including delivery of goods and other costs till the equipment is delivered at Site. The insurance policies to be taken should be on replacement value basis and/or incorporating escalation clause. Notwithstanding the extent of insurance cover and the amount of claim available from the underwriters, the Contractor shall be liable to make good the full



replacement/rectification value of all equipment/materials and to ensure their availability as per project requirements.

38.4 All costs on account of insurance liabilities covered under the Contract will be to Contractor's account and will be included in Contract Price, However, TSECL may from time to time, during the pendency of the Contract, ask the Contractor in writing to limit the insurance coverage, risks and in such a case, the parties to the Contract will agree for a mutual settlement, for reduction in Contract price to the extent of reduced premium amount. The Contractor, while arranging the insurance shall ensure to obtain all discounts on premium, which may be available for higher volume or for reason of financing arrangement of the project.

38.5 The clause entitled 'Insurance' under the Section - IV, covers the additional insurance requirements for the portion of the works to be performed at the Site.

### 39.0 **LIABILITY FOR ACCIDENTS AND DAMAGES**

Under the Contract, the Contractor shall be responsible for loss or damage to the equipment until the successful completion of commissioning as defined else-where in the Bidding Documents.

### 40.0 **DELAYS BY TSECL OR HIS AUTHORISED AGENTS**

40.1 In case the Contractor's performance is delayed due to any act on the part of TSECL or his authorized agents, then the Contractor shall be given due extension of time for the completion of the Works, to the extent of such act on the part of TSECL has caused delay in the Contractor's performance of the Contract.

Regarding reasonableness or otherwise of the extension of time, the decision of the TSECL shall be final.

### 41.0 **DEMURRAGE, WHARFAGE, ETC.**

All demurrage, wharf age and other expenses incurred due to delayed clearance of the material or any other reason shall be to the account of the Contractor.

### 42.0 **FORCE MAJEURE**

42.1 Force majeure is herein defined as any because which is beyond the control of the Contractor or TSECL as the case may be, which they could not foresee or with a reasonable amount of diligence could not have foreseen and which substantially affects the performance of the Contract, such as:

- a. Natural phenomena, including but not limited to floods, droughts, earthquakes and epidemics;
- b. Acts of any Government including but not limited to war, declared or undeclared, quarantines and embargoes.

Provided the contractor shall within Fifteen (15) days from the occurrence of such a cause notify TSECL in writing of such causes, acceptance of which will be given by TSECL after verification.

42.2 The Contractor or TSECL shall not be liable for delays in performing his obligations resulting from any force-majeure cause as referred to and/or defined above.

The date of completion will, subject to hereinafter provided, be extended by a reasonable time.



**43.0 SUSPENSION OF WORK**

43.1 TSECL reserves the right to suspend and reinstate execution of the whole or any part of the Works without invalidating the provisions of the Contract. Orders for Suspension or reinstatement of the Works will be issued by TSECL to the Contractor in writing. The time for completion of the works will be extended for a period equal duration of the suspension.

**44.0 CONTRACTOR'S DEFAULT**

44.1 If the Contractor shall neglect to execute the Works with due diligence and expertise or shall refuse or neglect to comply with any reasonable order given to him, in the Contract by the TSECL's Engineer in charge of the work in connection with the works or shall contravene the provisions of the Contract, TSECL may give notice in writing to the Contractor to make good the failure, neglect or contravention complained of. Should the Contractor fail to comply with the notice within Thirty (30) days from the date of serving the notice, then and in such case TSECL shall be at liberty to employ other workmen and forthwith execute such part of the Works as the Contractor, may have neglected to do or if TSECL shall think fit, without prejudice to any other right he may have under the Contract to take the work wholly or in part out of the Contractor's hands and re-contract with any other person or persons to complete the works or any part thereof and in that event TSECL shall have free use of all Contractor's equipment that may have been at the time on the Site in connection with the works without being responsible to the Contractor for fair wear and tear thereof and to the exclusion of any right of the Contractor over the same, and TSECL shall be entitled to retain and apply any balance which may otherwise be due on the Contract by him to the Contractor, or such part there of as may be necessary, to the payment of the cost of executing the said part of the Work or of completing the Works as the case may be. If the cost of completing of Works or executing a part there of as aforesaid shall exceed the balance due to the Contractor, the Contractor shall pay such excess. Such payment of excess amount shall be independent of the liquidated damages for delay, which the Contractor shall have to pay if the completion of Works is delayed.

44.2 In addition, such action by TSECL as aforesaid shall not relieve the Contractor of his liability to pay liquidated damages for delay in completion of Works as defined in clause 13.0 of this Section. Such action by TSECL as aforesaid, the termination of the Contract under this clause shall neither entitle the Contractor to reduce the value of the Contract Performance Guarantee nor the time thereof. The Contract Performance Guarantee shall be valid for the full value and for the full period of the Contract including guarantee period.

**45.0 TERMINATION OF CONTRACT ON OWNER'S INITIATIVE**

45.1 TSECL reserves the right to terminate the Contract either in part or in full due to reasons stipulated in the clause entitled "Contractor's Default." TSECL shall in such an event give Fifteen (15) days' notice in writing to the Contractor of his decision to do so.

45.2 The Contractor upon receipt of such notice shall discontinue the work on the date and to the extent specified in the notice.

45.3 If the Contractor is an individual or a proprietary concern and the individual or the proprietor dies and if the Contractor is a partnership concern and one of the partners dies then unless TSECL is satisfied that the legal representatives of the individual contractor or of the proprietor of propriety concern and in the case of partnership, the surviving partners, are capable of carrying out and completing the Contract, TSECL shall be entitled to cancel the Contract as to its uncompleted part without being in any way liable to payment of any compensation to the estate of deceased Contractor and/or to the surviving partners of the





Contractor's firm on account of the cancellation of the Contract. The decision of TSECL that the legal representatives of the deceased Contractor or surviving partners of the Contractor's firm cannot carry out and complete the Contract shall be final and binding on the parties.

### **RESOLUTION OF DISPUTES**

#### **46.0 SETTLEMENT OF DISPUTES**

- 46.1 Any dispute(s) or difference(s) arising out of or in connection with the Contract shall, to the extent possible, be settled amicably between the parties.
- 46.2 If any dispute or difference of any kind whatsoever shall arise between Deputy General Manager in charge of the work and the Contractor, arising out of the Contract for the performance of the Works whether during the progress of the Works or after its completion or whether before or after the termination, abandonment or breach of the Contract, it shall, in the first place, be referred to and settled by the Superintending Engineer of the concerned circle /Chief Engineer as the case may be, who, within a period of Thirty (30) days after being requested by either party to do so, shall give written notice of his decision to both the parties.
- 46.3 In the event the Contractor being dissatisfied with any such decision, the matters in dispute shall be referred to arbitration as hereinafter provided.

#### **47.0 ARBITRATION**

- 47.1 All disputes or differences in respect of which the decision, if any, of the Engineer has not become final or binding as aforesaid shall be settled by arbitration in the manner hereinafter provided.
- 47.1.1 The arbitration shall be conducted by an arbitrator, to be nominated by TSECL and he will be the sole arbitrator to conduct the arbitration.
- 47.1.2 The arbitration shall be conducted in accordance with the provisions of the Indian Arbitration & Reconciliation Act, 1996 or any statutory modification thereof. The venue of arbitration shall be at **Agartala**.
- 47.2 The arbitrators may, from time to time with the consent of all the parties enlarge the time for making the award.
- 47.3 The arbitrator shall have full powers to review and/or revise any, decision, opinion, direction, certification or valuation of the Engineer in accordance with the Contract, and neither party shall be limited in the proceedings before such arbitrators to the condense or arguments out before the Engineer for the purpose of obtaining the said decision.
- 47.4 During settlement of disputes and arbitration proceedings, both parties shall be obliged to carry out their respective obligations under the Contract.

#### **48.0 RECONCILIATION OF ACCOUNTS**

The Contractor shall prepare and submit every six months, a statement covering payments claimed and the payments received vis-à-vis the works executed, for reconciliation of accounts with the owner's Engineer in charge of the work. The Contractor shall also prepare and submit a detailed account of Materials received from TSECL and utilized by him for reconciliation purpose.

#### **49.0 TRAINING OF OWNER'S PERSONNEL**

- 49.1 The Contractor shall undertake to train free of cost, two engineering personnel selected and sent by TSECL at the works of the manufacturer. The period and nature of training for the personnel shall be agreed upon mutually between the Contractor and TSECL. These engineering personnel shall be given special training in the shops, where the equipment shall





be manufactured and/or in their Collaborator's works and where possible, in any other plant where equipment manufactured by the Contractor or his Collaborator is under installation, operation, or testing to enable those personnel to become familiar with the equipment being supplied by the Contractor.

- 49.2 All traveling and living expenses for the engineering personnel to be trained during the total period of training shall be borne by the Contractor. These engineering personnel, while undergoing training, shall be responsible to the Contractor for discipline.
- 49.3 TSECL shall not be entitled for any rebate, whatsoever on any account in the event of his failing to avail of the training facilities, for any reason.

\*\*\*\*\*



## SECTION-IV

### ERECTION CONDITIONS OF CONTRACT

#### **1.0 GENERAL**

1.1 The following shall supplement the conditions already contained in the other parts of these specifications and document and shall govern the portion of the work of this Contract to be performed at Site.

1.2 The Contractor upon signing of the Contract shall, in addition to a Project Coordinator, nominate another responsible officer as his representative at Site suitably designated for the purpose of overall responsibility and co-ordination of the works to be performed at Site. Such person shall function from the Site Office of the Contractor.

#### **2.0 REGULATION OF LOCAL AUTHORITIES**

2.1 The Contractor shall comply with all the rules and regulations of local authorities during the performance of his field activities. He shall also comply with the Minimum Wages Act, 1948 and the Payment of Wages Act (both of the Government of India) and the rules made there-under in respect of any employee or workman employed or engaged by him or his Sub-Contractor.

2.2 All registration and statutory inspection fees, if any, in respect of his work pursuant to this Contract shall be to the account of the Contractor. However, any registration, statutory inspection fees lawfully payable under any statutory laws and its amendments from time to time during erection in respect of the equipment ultimately to be owned by the Owner, shall be to the account of TSECL. Should any such inspection or registration need to be re-arranged due to the fault of the Contractor or his Sub-Contractor, the additional fees to such inspection and/or registration shall be borne by the Contractor.

#### **3.0 OWNER'S LIEN ON EQUIPMENT**

TSECL shall have a lien on all equipment including those of the Contractor brought to the Site for the purpose **of erection, testing and commissioning** of the equipment to be supplied & erected under the Contract. TSECL shall continue to hold the lien on all such equipment throughout the period of Contract. No material brought to the Site shall be removed from the Site by the Contractor and/or his Sub-Contractors without the prior written approval of the Engineer.

#### **4.0 INSPECTION, TESTING AND INSPECTION CERTIFICATES**

The provisions of the clause entitled Inspection, Testing and Inspection Certificates under Technical Specification; General Terms & Conditions (GTC) shall also be applicable to the erection portion of the Works. The **Deputy General Manager in charge** of the work shall have the right to re-inspect any equipment though previously inspected at the Contractor's works, before and after the same are erected at Site. If by the above inspection, the **Deputy General Manager in charge** of the work rejects any equipment, the Contractor shall make good for such rejections either by replacement or modification / repairs as may be necessary to the satisfaction of TSECL. Such replacements shall also include the replacements or re-execution of such of those works of other Contractors and/or agencies, which might have got damaged or affected by the replacements or re-work done to the Contractor's work.

#### **5.0 ACCESS TO SITE AND WORKS ON SITE**

5.1 Suitable access to the Site shall be afforded to the Contractor by TSECL in reasonable time.



5.2 In the execution of the works, no person other than the Contractor or his duly appointed representative, Sub-Contractor and workmen, shall be allowed to do work on the Site, except by the special permission, in writing of the site Engineer of TSECL or his representative.

## **6.0 CONTRACTOR'S SITE OFFICE ESTABLISHMENT**

The Contractor shall establish a Site Office at the Site and keep posted an authorized representative for the purpose of the Contract. Any written order or instruction of the Engineer in charge of the work or his duly authorized representative shall be communicated to the said authorized resident representative of the Contractor and the same shall be deemed to have been communicated to the Contractor at his legal address.

## **7.0 CO-OPERATION WITH OTHER CONTRACTORS**

7.1 The Contractor shall co-operate with all other Contractors or tradesmen of TSECL, who may be performing other works on behalf of TSECL and the workmen who may be employed by TSECL and doing work in the vicinity of the Works under the Contract. The Contractor shall also so arrange to perform his work as to minimize, to the maximum extent possible, interference with the work of other Contractors and their workmen. Any injury or damage that may be sustained by the employees of the other Contractors and TSECL, due to the Contractor's work shall promptly be made good at the Contractor's own expense. The site Engineer of TSECL shall determine the resolution of any difference or conflict that may arise between the Contractor and other Contractors or between the Contractor and the workmen of TSECL in regard to their work. If the work of the Contractor is delayed because of any acts of omission of another Contractor, the Contractor shall have no claim against TSECL on that account other than an extension of time for completing his Works.

7.2 The Site Engineer of TSECL shall be notified promptly by the Contractor of any defects in the other Contractor's works that could affect the Contractor's Works. The Engineer shall determine the corrective measures if any required rectifying this situation after inspection of the works and such decisions by the Engineer shall be binding on the Contractor.

## **8.0 DISCIPLINE OF WORKMEN**

The Contractor shall adhere to the disciplinary procedure set by the site Engineer of TSECL in respect of his employees and workmen at Site. The Engineer shall be at liberty to object to the presence of any representative or employee of the Contractor at the Site, if in the opinion of the Engineer such employee has misconduct himself or is incompetent or negligent or otherwise undesirable and then the Contractor shall remove such a person objected to and provide in his place a competent replacement.

## **9.0 CONTRACTOR'S FIELD OPERATION**

9.1 The Contractor shall keep the site Engineer of TSECL informed in advance regarding his field activity plans and schedules for carrying-out each part of the works. Any review of such plan or schedule or method of work by the site Engineer of TSECL shall not relieve the Contractor of any of his responsibilities towards the field activities. Such reviews shall also not be considered as an assumption of any risk or liability by TSECL or any of his representatives and no claim of the Contractor shall be entertained because of the failure or inefficiency of any such plan or schedule or method of work reviewed. The Contractor shall be solely responsible for the safety, adequacy and efficiency of plant and equipment and his erection methods.

9.2 The Contractor shall have the complete responsibility for the conditions of the Work-Site including the safety of all persons employed by him or his Sub-Contractor and all the



properties under his custody during the performance of the work. This requirement shall apply continuously till the completion of the Contract and shall not be limited to normal working hours. The construction review by the site Engineer of TSECL is not intended to include review of Contractor's safety measures in, on or near the work Site, and their adequacy or otherwise.

## **10.0 PHOTOGRAPHS AND PROGRESS REPORT**

10.1 The Contractor shall furnish Three (3) prints each to the Site Engineer of progress photographs of the work done at Site. Photographs shall be taken as and when indicated by the Site Engineer of TSECL or his representative. Photographs shall be adequate in size and number to indicate various stages of erection. Each photograph shall contain the date, the name of the Contractor and the title of the photograph.

10.2 The above photographs shall accompany the monthly progress report detailing-out the progress achieved on all erection activities as compared to the schedules. The report shall also indicate the reasons for the variance between the scheduled and actual progress and the action proposed for corrective measures, wherever necessary.

## **11.0 MAN-POWER REPORT**

11.1 The Contractor shall submit to the Site Engineer of TSECL, on the first day of every month, a man hour schedule for the month, detailing the man hours scheduled for the month, skill-wise and area-wise.

11.2 The Contractor shall also submit to the Site Engineer of TSECL, on the first day of every month, a man power report of the previous month detailing the number of persons scheduled to have been employed and actually employed, skill-wise and the areas of employment of such labor.

## **12.0 PROTECTION OF WORK**

The Contractor shall have total responsibility for protecting his works till it is finally taken over by TSECL. No claim shall be entertained by TSECL for any damage or loss to the Contractor's works and the Contractor shall be responsible for complete restoration of the damaged works to original conditions to comply with the specification and drawings, should any such damage to the Contractor's works occur because of any other party not being under his supervision or control. The Contractor shall make his claim directly with the party concerned. If disagreement or conflict or dispute develops between the Contractor and the other party or parties concerned regarding the responsibility for damage to the contractor's works, the same shall be resolved as per the provisions of the Clause 7.0 above entitled "Cooperation with other Contractors". The Contractor shall not cause any delay in the repair of such damaged works because of any delay in the resolution of such dispute. The Contractor shall proceed to repair the Work immediately and no cause thereof will be assigned pending resolution of such disputes.

## **13.0 EMPLOYMENT OF LABOUR**

13.1 The Contractor shall be expected to employ on the work only his regular skilled employees with experience of this particular work. No female labor shall be employed after darkness. No person below the age of eighteen years shall be employed.

13.2 All traveling expenses including provisions of all necessary transport to and from Site, lodging allowances and other payments to the Contractor's employees shall be the sole responsibility of the Contractor.



13.3 The hours of work on the Site shall be decided by the site Engineer of TSECL and the Contractor shall adhere to it. Working hours shall normally be Eight (8) hours per day – Monday through Saturday and may have to be extended in the interest of work.

13.4 The Contractor's employees shall wear identification badges while on work at Site.

13.5 In case TSECL becomes liable to pay any wages or dues to the labor or any Government agency under any of the provisions of the Minimum Wages Act, Workmen Compensation Act, Contract Labor Regulation Abolition Act or any other law due to act of omission of the Contractor, TSECL may make such payments and shall recover the same from the Contractor's bills.

#### 14.0 FACILITIES TO BE PROVIDED

##### *By the Contractor*

#### 14.1 Tools, tackles and scaffoldings

The Contractor shall provide all the construction equipment, tools, tackles and scaffoldings required for pre-assembly, erection, testing and commissioning of the equipment covered under the Contract. He shall submit a list of all such materials to the site Engineer of TSECL before the commencement of pre-assembly at Site. These tools and tackles shall not be removed from the Site without the written permission of the site Engineer.

#### 14.2 First – aid

The Contractor shall provide necessary first-aid facilities for all his employees, representatives and workmen working at the Site. Enough number of Contractor's personnel shall be trained in administering first – aid.

#### 14.3 Cleanliness

The Contractor shall be responsible for keeping the entire area allotted to him clean and free from rubbish, debris etc. during the period of Contract. The Contractor shall employ enough number of special personnel to thoroughly clean his work-area at least once in a day. All such rubbish and scrap material shall be stacked or disposed in a place to be identified by the site Engineer of TSECL. Materials and stores shall be so arranged to permit easy cleaning of the area. In areas where equipment might drip oil and cause damage to the floor surface, a suitable protective cover of a flame resistant, oil proof sheet shall be provided to protect the floor from such damage.

#### 14.4 Communication

The contractor shall extend the telephone & telex facilities, if available at Site, for the purposes of interaction with the site office by him and TSECL.

By the Owner

#### 14.5 Space

a) Land for Contractor's Office, Store, and Workshop etc if available shall be provided by TSECL. Otherwise, contractor has to arrange at his own cost and responsibilities the accommodation for his site office, store and workshop etc.

b) The Site Engineer of TSECL shall at his discretion and for the duration of execution of the Contract make available at site, land for construction of Contractor's field office, workshop, stores, magazines for explosives in isolated locations, assembling yard, etc. required for execution of the Contract. Any construction of temporary roads,



offices, workshop, etc. as approved by the site Engineer of TSECL shall be done by the Contractor at his cost.

- c) On completion of work, the Contractor shall hand over the land duly cleaned to the site Engineer of TSECL. Until and unless the Contractor has handed over the vacant possession of land allotted to him for the above purpose, the payment of his final bill shall not be made. The Contractor shall be made liable to pay for the use and occupation at the rates to be determined by the Engineer if the Contractor over stays in the land after the Contract is completed.

#### **14.6 Electricity – Power Supply**

Where power supply is available with TSECL for construction purpose, the same shall be provided at the job at one point of the distribution system as may be decided by site Engineer of TSECL. The charge for extension of service line and energy consumption charges shall be borne by the contractor. In case the contractor fails to pay the related charge of extension of service line and energy consumption within due date of the bill raised for the purpose, the amount will be deducted from the progressive bill of the contractor.

#### **14.7 Water**

Free supply of water shall be made available for the construction purpose whenever water is available and the same shall be given at an agreed single point at the Site. Any further distribution shall be the responsibility of the Contractor. Free drinking water if available shall also be provided at one agreed point in the Site. Further distribution either to his labour colony or his work Site or to his office shall be the responsibility of the Contractor.

#### **15.0 LINES AND GRADES**

All the works shall be performed on the lines, grades and elevations indicated on the drawings. The Contractor shall be responsible to locate and lay-out the works. Basic horizontal and vertical control points shall be established and marked by the Engineer at Site at suitable points. These points shall be used as datum for the works under the Contract. The Contractor shall inform the site Engineer of TSECL well in advance of the times and places at which he wishes to do work in the area allotted to him so that suitable datum points may be established and checked by the site Engineer to enable the Contractor to proceed with his works. Any work done without being properly located may be removed and/or dismantled at contractor expense.

#### **16.0 FIRE PROTECTION**

- 16.1 The work procedures that are to be used during the erection shall be those which minimize fire hazards to the extent practicable. Combustible materials, combustible waste and rubbish shall be collected and removed from the Site at least once each day. Fuels, oils and volatile or inflammable materials shall be stored away from the construction and equipment and materials storage areas in safe containers. In-treated materials shall not at all be used at Site for any other purpose unless otherwise specified. If any such materials are received with the equipment at the Site, the same shall be removed and replaced with acceptable material before moving into the construction or storage area.
- 16.2 Similarly corrugated paper fabricated cartons etc. shall not be permitted in the construction area either for storage or for handling of materials. All such materials used shall be of water proof and flame-resistant type. All the other materials such as working drawings, plans etc. which are combustible but are essential for the works to be executed shall be protected





against combustion resulting from welding sparks, cutting flames and other similar fire sources.

- 16.3 All the Contractor's supervisory personnel and sufficient number of workers shall be trained for fire-fighting and shall be assigned specific fire protection duties. Enough of such trained personnel must be available at the Site during the entire period of the Contract.
- 16.4 The Contractor shall provide enough fire protection equipment of the types and number for the ware-houses, office, temporary structures, labour colony area etc. Access to such fire protection equipment shall be easy and kept open at all time.

## **17.0 SECURITY**

The Contractor shall have total responsibility for all equipment and materials in his custody/stores, loose, semi-assembled and/or erected by him at Site. The contractor shall make suitable security arrangements including employment of security personnel to ensure the protection of all materials, equipment and works from theft, fire, pilferage and any other damages and loss. All materials of the Contractor shall enter and leave the project Site only with the written permission of site Engineer of TSECL in the prescribed manner.

## **18.0 CONTRACTOR'S AREA LIMITS**

The site Engineer of TSECL shall mark-out the boundary limits of access roads, parking spaces, storage and construction areas for the Contractor and the Contractor shall not trespass the areas not so marked out for him. The Contractor shall be responsible to ensure that none of his personnel move out of the areas marked out for his operations. In case of such a need for the Contractor's personnel to work out of the areas marked out for him, the same shall be done only with the written permission of the site Engineer of TSECL.

## **19.0 CONTRACTOR'S CO-OPERATION**

In case where the performance of the erection work by the Contractor affects the operation of the system facilities of TSECL, such erection work of the Contractor shall be scheduled to be performed only in the manner stipulated by the site Engineer and the same shall be acceptable at all times to the Contractor. The site Engineer may impose such restrictions on the facilities provided to the Contractor such as electricity, water etc. as he may think fit in the interest of TSECL and the Contractor shall strictly adhere to such restrictions and co-operate with the site Engineer of TSECL. It will be the responsibility of the Contractor to provide all necessary temporary instrumentation and other measuring devices required during start-up and operation of the equipment systems which are erected by him. The Contractor shall also be responsible for flushing and initial filling of all the oil and lubricants required for the equipment furnished and erected by him, so as to make such equipment ready for operation. The Contractor shall be responsible for supplying such flushing oil and other lubricants unless otherwise specified elsewhere in the document and specification.

## **20.0 MATERIALS HANDLING AND STORAGE**

- 20.1 All the equipment furnished under the Contract and arriving at Site shall be promptly received, unloaded, transported and stored in the storage arrange by the contractor at his risk and cost.
- 20.2 The Contractor shall be responsible for examining all the shipment and notify the Site Engineer of TSECL immediately of any damage, shortage, discrepancy etc. for the purpose of information only. The Contractor shall submit to the site Engineer of TSECL every week a report detailing all the receipts during the week. However, the Contractor shall be solely responsible for any shortages or damage in transit, handling and/or in storage and erection of



the equipment at Site. Any damage, wharfage and other such charges claimed by the transporters, railways etc. shall be to the account of the Contractor.

- 20.3 The Contractor shall maintain an accurate and exhaustive record detailing out the list of all equipment received by him for the purpose of erection and keep such record open for the inspection by the Site Engineers / Higher officials of TSECL.
- 20.4 All equipment shall be handled very carefully to prevent any damage or loss. No bare wire ropes, slings, etc. shall be used for unloading and/or handling of the equipment without the specific written permission of the Site Engineer. The equipment stored shall be properly protected to prevent damage either to the equipment or the floor where they are stored. The equipment from the store shall be moved to the actual location at the appropriate time so as to avoid damage of such equipment at Site.
- 20.5 All electrical panels, control gears, motors and such other devices shall be properly dried by heating before they are installed and energized. Motor bearings, slip rings, commutators and other exposed parts shall be protected against moisture ingress and corrosion during storage and periodically inspected.
- 20.6 All the electrical equipment such as motors, generators, etc. shall be tested for insulation resistance at least once in a month from the date of receipt till the date of commissioning and a record of such measured insulation values maintained by the Contractor. Such records shall be made available for inspection by the Site Engineers / Higher officials of TSECL.
- 20.7 The Contractor shall ensure that all the packing materials and protection devices used for the various equipment's during transit and storage are removed before the equipment are installed.
- 20.8 The consumable and other supplies likely to deteriorate due to storage must be thoroughly protected and stored in a suitable manner to prevent damage or deterioration in quality by storage.
- 20.9 All the materials stored in the open or dusty location must be covered with suitable weather-proof and flame proof covering material wherever applicable.
- 20.10 If the materials belonging to the Contractor are stored in areas other than those earmarked for him, the Site Engineer shall have the right to get it moved to the area earmarked for the Contractor at the Contractor's cost.
- 20.11 The Contractor shall be responsible for making suitable indoor storage facilities to store all equipment which require indoor storage. Normally, all the electrical equipment such as motors, control gear, generators, exciters and consumables like electrodes, lubricants etc. shall be stored in the closed storage space. The site Engineer, in addition, may direct the Contractor to move certain other materials, which in his opinion shall require indoor storage, to indoor storage areas, which the Contractor shall strictly comply with.

## **21.0 CONSTRUCTION MANAGEMENT**

- 21.1 The field activities of the Contractors working at Site shall be coordinated by the Site Engineer of TSECL and his decision shall be final in resolving any disputes or conflicts between the Contractor and other Contractors and tradesmen regarding scheduling and co-ordination of work. Such decision by Site Engineer of TSECL shall not be a cause for extra compensation or extension of time for the Contractor.
- 21.2 The Site Engineer of TSECL shall hold weekly meeting with the Site Engineer / Supervisor of the contractor. The Site Engineer / Supervisor of the contractor shall attend such meetings and take notes of the discussions during the meeting and the decision of the Site Engineer of



TSECL and shall strictly adhere to those decisions in performing his works. In addition to the above weekly meeting, the Site Engineer / Higher officials of TSECL may call for other meeting with the Site Engineer / Supervisor / any other authorized representative of the contractor and in such a case the personnel of the contractor shall attend such meetings.

- 21.3 Time is the essence of the Contract and the Contractor shall be responsible for performance of his works in accordance with the specified construction schedule. If at any time, the Contractor is falling behind the schedule, he shall take necessary action to make good for such delays by increasing his work force or by working overtime or otherwise accelerate the progress of the work to comply with the schedule and shall communicate such actions in writing to the Site Engineer of TSECL, satisfying that his action shall compensate for the delay. The Contractor shall not be allowed any extra compensation for such action.
- 21.4 TSECL shall, however, not be responsible for provision of additional labour and/or materials or supply or any other services to the Contractor.

## **22.0 FIELD OFFICE RECORDS**

The Contractor shall maintain at his Site office up-to-date copies of all drawings, specifications and other Contract Documents and any other supplementary data complete with all the latest revisions thereto. The Contractor shall also maintain in addition the continuous record of all changes to the above Contract Documents, drawings, specifications, supplementary data, etc. effected at the field and on completion of his total assignment under the Contract, shall incorporate all such changes on the drawings and other engineering data to indicate as installed conditions of the equipment furnished and erected under the Contract. Such drawings and engineering data shall be submitted to the Deputy General Manager in charge of the work in required number of copies.

## **23.0 CONTRACTOR'S MATERIALS BROUGHT ON TO SITE**

- 23.1 The Contractor shall bring to Site all equipment, components, parts, materials, including construction equipment, tools and tackles for the purpose of the works under intimation to the Site Engineer. All such goods shall, from the time of their being brought vest in TSECL, but may be used for the purpose of the Works only and shall not on any account be removed or taken away by the Contractor without the written permission of the Site Engineer of TSECL. The Contractor shall nevertheless be solely liable and responsible for any loss or destruction thereof and damage thereto.
- 23.2 After the completion of the Works, the Contractor shall remove from the Site under the direction of the Site Engineer of TSECL the materials such as construction equipment, erection tools and tackles, scaffolding etc. with the written permission from him.

## **24.0 PROTECTION OF PROPERTY AND CONTRACTOR'S LIABILITY**

- 24.1 The Contractor shall be responsible for any damage resulting from his operations. He shall also be responsible for protection of all persons including members of public and employees of TSECL and the employees of other Contractors and Sub-contractors and all public and private property including structures, building, other plants and equipment and utilities either above or below the ground.
- 24.2 The Contractor shall ensure provision of necessary safety equipment such as barriers, signboards, warning lights and alarms, etc. to provide adequate protection and safety to persons and property.

## **25.0 INSURANCE**



25.1 In addition to the conditions covered under the Clause entitled "Insurance" in General Terms and conditions of Contract, the following provisions shall also apply to the portion of works to be done beyond the Contractor's own or his Sub-contractor's manufacturing Works.

25.2 **Workman's Compensation Insurance**

This insurance shall protect the Contractor against all claims applicable under the Workman's Compensation Act, 1948. This policy shall also cover the Contractor against claims for injury, disability, disease or death of his or his Sub-Contractor's employee, which for any reason are not covered under the Workman's Compensation Act, 1948. The liabilities shall not be less than:

Workman's Compensation: As per statutory Provisions.

Employee's liability : As per statutory Provisions.

25.3 **Comprehensive Automobile Insurance**

This insurance shall be in such a form to protect the Contractor against all claims for injuries, disability, disease and death to members of public including the employees of TSECL and damage to the property of other arising from the use of motor vehicles during on or off the Site operations, irrespective of the ownership of such vehicles.

25.4 **Comprehensive General Liability Insurance**

25.4.1 This insurance shall protect the Contractor against all claims arising from injuries, disabilities, disease or death of members of public or damage to property of others, due to any act or omission on the part of the Contractor, his agents his employees, his representatives and Sub-contractors or from riots, strikes and civil commotion. This insurance shall also cover all the liabilities of the Contractor arising out of the Clause stipulated in the General Terms and Conditions of Contract.

25.4.2 The hazards to be covered will pertain to all the works and areas where the Contractor, his Sub-contractors, his agents and his employees have to perform work pursuant to the Contract.

25.5 The above is only illustrative list of insurance covers normally required and it shall be the responsibility of the Contractors to maintain all necessary insurance coverage to the extent both in time and amount to take care of all his liabilities either direct or indirect, in pursuance of the Contract.

26.0 **UNFAVOURABLE WORKING CONDITIONS**

The Contractor shall confine all his field operations to those works which can be performed without subjecting the equipment and materials to adverse effects during inclement weather conditions, like monsoon, storms, etc. and during other unfavorable construction conditions. No field activities shall be performed by the Contractor under conditions which might adversely affect the quality and efficiency thereof, unless special precautions or measures are taken by the Contractor in a proper and satisfactory manner in the performance of such Works and with the concurrence of the Site Engineer of TSECL. Such unfavorable construction conditions shall in no way relieve the Contractor of his responsibility to perform the Works as per the Schedule.



## 27.0 WORK & SAFETY REGULATION

- 27.1 The Contractor shall ensure proper safety of all the workmen, materials plant and equipment belonging to him or to owner or to others, working at the Site. The Contractor shall also be responsible for provision of all safety notices and safety equipment required both by the relevant legislations and also by the Site Engineer as he may deem necessary.
- 27.2 The Contractor shall notify well in advance to the Site Engineer of his intention to bring to the Site any container filled with liquid or gaseous fuel or explosive or petroleum substance or such chemicals, which may involve hazards. The Site Engineer shall have the right to prescribe the conditions, under which such container is to be stored, handled and used during the performance of the works and the Contractor shall strictly adhere to and comply with such instructions. The Site Engineer shall have the right at his sole discretion to inspect any such container or such construction plant/equipment for which material in the container is required to be used and if in his opinion, its use is not safe, he may forbid its use. No claim due to such prohibition shall be entertained by TSECL.
- 27.3 Further, any such decision of the Site Engineer shall not, in any way, absolve the Contractor of his responsibilities and in case, use of such a container or entry thereof into the Site area is forbidden by the Site Engineer, the Contractor shall use alternative methods with the approval of the Deputy General Manager in charge of the work without any cost implication to TSECL or extension of work schedule.
- 27.4 Where it is necessary to provide and/or store petroleum products or petroleum mixtures and explosives, the Contractor shall be responsible for carrying-out such provision and/or storage in accordance with the rules and regulations laid down in the Petroleum Act 1934, Explosives Act, 1948, and Petroleum and Carbide of Calcium Manual published by the Chief Inspector of Explosives of India. All such storage shall have prior approval of the Site Engineer of TSECL. In case, any approvals are necessary from the Chief Inspector (Explosives) or any statutory authorities, the Contractor shall be responsible for obtaining the same.
- 27.5 All equipment used in construction and erection by Contractor shall meet Indian/International Standards and where such standards do not exist, the Contractor shall ensure these to be absolutely safe. All equipment's shall be strictly operated and maintained by the Contractor in accordance with manufacturer's operation Manual and safety instructions and as per Guidelines/Rules of TSECL in this regard.
- 27.6 Periodical Examinations and all tests for all lifting/hoisting equipment & tackles shall be carried-out in accordance with the relevant provisions of Factories Act 1948, Indian Electricity Act 1910 and associated Laws/Rules in force from time to time. A register of such examinations and tests shall be properly maintained by the Contractor and shall be promptly produced as and when desired by the Site Engineer of TSECL or by the person authorized by TSECL.
- 27.7 The Contractor shall be fully responsible for the safe storage of his and his sub-contractor's radio-active sources in accordance with BARC/DAE Rules and other applicable provisions. All precautionary measures stipulated by BARC/DAE in connection with use, storage and handling of such material shall be taken by Contractor.
- 27.8 The Contractor shall provide suitable safety equipment of prescribed standard to all employees and workmen according to the need, as may be directed by Site Engineer of TSECL who shall also have right to examine this safety equipment to determine their suitability, reliability, acceptability and adaptability.





- 27.9 Where explosives are to be used, the same shall be used under the direct control and supervision of an expert, experienced, qualified and competent person strictly in accordance with the Code of Practices/Rules framed under the Indian Explosives Act pertaining to handling, storage and use of explosives.
- 27.10 The Contractor shall provide safe working conditions to all workmen and employees at the Site including safe means of access, railings, stairs, ladders, scaffolding s, etc. The scaffolding shall be erected under the control and supervision of an experienced and competent person. For erection, good and standard quality material only shall be used by the Contractor.
- 27.11 The Contractor shall not interfere or disturb electric fuses, wiring and other electrical equipment belonging to TSECL or other contractors under any circumstances, whatsoever, unless expressly permitted in writing by Site Engineer of TSECL to handle such fuses, wiring or electrical equipment.
- 27.12 Before the Contractor connects any electrical appliances to any plug or socket belonging to TSECL, he shall:
- Satisfy the Site Engineer of TSECL that the appliance is in good working condition:
  - Inform the site Engineer of the maximum current rating, voltage and phases of the appliances;
  - Obtain permission of the Site Engineer detailing the sockets to which the appliances may be connected.
- 27.13 The Site Engineer shall not grant permission to connect until he is satisfied that;
- The appliance is in good condition and is fitted with suitable plug;
  - The appliance is fitted with a suitable cable having two earth conductors, one of which shall be an earthed metal sheath surrounding the cores.
- 27.14 No electric cable in use by the Contractor/TSECL shall be disturbed without prior permission. No weight of any description shall be imposed on any cable and no ladder or similar equipment shall rest against or attached to it.
- 27.15 No repair work shall be carried out on any live equipment. The equipment must be declared safe by the Site Engineer before any repair work is carried out by the Contractor. While working on electric lines/equipment whether live or dead, suitable type and sufficient quantity of tools shall have to be provided by Contractor to electricians/workmen/officers.
- 27.16 The Contractors shall employ necessary number of qualified, full-time electricians/Electrical Supervisors to maintain his temporary electrical installations.
- 27.17 In case any accident occurs during the construction/erection or other associated activities undertaken by the Contractor thereby causing any minor or major or fatal injury to his employees due to any reason, whatsoever, it shall be the responsibility of the Contractor to promptly inform the same to the Site Engineer of TSECL and also to all the authorities envisaged under the applicable laws.
- 27.18 The Site Engineer of TSECL shall have the right at his sole discretion to stop the work, if in his opinion the work is being carried out in such a way that it may cause accidents and endanger the safety of the persons and/or property, and/or equipment. In such cases, the Contractor shall be informed in writing about the nature of hazards and possible injury/accident and he shall comply to remove short-comings promptly. The Contractor after stopping the specific work can, if felt necessary, appeal against the order of stoppage of work





to the Deputy General Manager in charge of the work within 3 days of such stoppage of work and the decision of the Deputy General Manager in charge of the work in this respect shall be conclusive and binding on the Contractor.

27.19 The Contractor shall not be entitled for any damages/compensation for stoppage of work due to safety reasons as provided in para 27.18 above and the period of such stoppage of work shall not be taken as an extension of time for completion of work and shall not be the ground for waiver of levy of liquidated damages.

27.20 It is mandatory for the Contractor to observe during the execution of the works, the requirements of safety rules which would generally include but not limited to the following:

**Safety Rules:**

- a) Each employee shall be provided with initial indoctrination regarding safety by the Contractor, so as to enable him to conduct his work in a safe manner.
- b) No employee shall be given a new assignment of work unfamiliar to him without proper introduction as to the hazard's incident thereto, both to himself and his fellow employees.
- c) Under no circumstances shall an employee hurry or take unnecessary chance when working under hazardous conditions.
- d) Employees must not leave naked fires unattended. Smoking shall not be permitted around fire prone areas and adequate firefighting equipment shall be provided at crucial locations.
- e) Employees under the influence of any intoxicating beverage, even to the slightest degree shall not be permitted to remain at work.
- f) There shall be a suitable arrangement at every work site for rendering prompt and sufficient first aid to the injured.
- g) The staircases and passageways shall be adequately lighted.
- h) The employees when working around moving machinery must not be permitted to wear loose garments. Safety shoes are recommended when working in shops or places where materials or tools are likely to fall. Only experienced workers shall be permitted to go behind guard rails or to clean around energized or moving equipment.
- i) The employees must use the standard protection equipment intended for each job. Each piece of equipment shall be inspected before and after it is used.
- j) Requirements of ventilation in underwater working to licensed and experienced divers, use of gum boots for working in slushy or in inundated conditions are essential requirements to be fulfilled.
- k) In cases or rock excavation blasting shall invariably be done through licensed blasters and other precautions during blasting and storage/transport of charge material shall be observed strictly.

27.21 The Contractor shall follow and comply with all relevant Safety Rules, relevant provisions of applicable laws pertaining to the safety of workmen, employees, plant and equipment as may be prescribed from time to time without any demur, protest or contest or reservation. In case of any discrepancy between statutory requirement and relevant Safety Rules referred above, the later shall be binding on the Contractor unless the statutory provisions are more stringent.



27.22 If the Contractor does not take all safety precautions and/or fails to comply with the Safety Rules as prescribed by Consortium or under the applicable law for the safety of the equipment and plant and for the safety of personnel and the Contractor does not prevent hazardous conditions which cause injury to his own employees or employees of other contractors, or Employees of TSECL or any other person who are at Site or adjacent thereto, the Contractors shall be responsible for payment of compensation to Consortium members as per the compensation order issued by the appropriate authority of Government of Tripura / verdict issued by court.

The compensation mentioned above shall be in addition to the compensation payable to the workmen / employees under the relevant provisions of the Workman's Compensation Act and rules framed there under or any other applicable laws as applicable from time to time. In case TSECL is made to pay such compensation then the amount of such compensation shall be deducted from the progressive bills / contract performance guaranty of the contractor.

## 28.0 CODEREQUIREMENTS

The erection requirements and procedures to be followed during the installation of the equipment shall be in accordance with the relevant Codes and accepted good engineering practice, the Engineering Drawings and other applicable Indian recognized codes and laws and regulations of the Government of India.

## 29.0 FOUNDATION DRESSING & GROUTING

- i. The surfaces of foundations shall be dressed to bring the top surface of the foundations to the required level, prior to placement of equipment / equipment bases on the foundations.
- ii. All the equipment bases and structural steel base plates shall be grouted and finished as per these specifications unless otherwise recommended by the equipment manufacturer.
- iii. The concrete foundation surfaces shall be properly prepared by chipping, grinding as required to bring the type of such foundation to the required level, to provide the necessary roughness for bondage and to assure enough bearing strength. All laitance and surface film shall be removed and cleaned.

## 30.0 Grouting Mix

30.1 The Grouting mixture shall be composed of Portland cement, sand and water. The Portland cement to be used shall conform to ISI No. 269 or equivalent. Sand shall conform to ISI No. 383/2386 or equivalent. All grouts shall be thoroughly, mixed for not less than five minutes in an approved mechanical mixer and shall be used immediately after mixing.

## 30.2 Placing of Grout

30.2.1 After the base has been prepared, its alignment and level has been checked and approved and before actually placing the grout a low dam shall be set around the base at a distance that shall permit pouring and manipulation of the grout. The height of such dam shall be at least 25 mm. above the bottom of the base. Suitable size and number of chains shall be introduced under the base before placing the grout, so that such chains can be moved back and forth to push the grout into every part of the space under the base.

30.1.2 The grout shall be poured either through grout holes provided or shall be poured at one side or at two adjacent sides giving it a pressure head to make the grout move in a solid mass under the base and out in the opposite side. Pouring shall be continued until the entire space below the base is thoroughly filled and the grout stands at least 25 mm. higher all around



than the bottom of the base. Enough care should be taken to avoid any air or water pockets beneath the bases. Vibrator shall be used to avoid any air or water pockets.

### 30.2 Finishing of the Edges of the Grout

The poured grout should be allowed to stand undisturbed until it is well set. Immediately thereafter, the dam shall be removed and grout which extends beyond the edges of the structural or equipment base plates shall be cut off, flushed and removed. The edges of the grout shall then be pointed and finished with 1:6 cement mortar pressed firmly to bond with the body of the grout and smoothness with a tool to present a smooth vertical surface. The work shall be done in a clean and scientific manner and the adjacent floor spaces, exposed edges of the foundations, and structural steel and equipment base plates shall be thoroughly cleaned of any spillage of the grout.

### 30.3 Checking of Equipment After Grouting

After the grout is set and cured, the Contractor shall check and verify the alignment of equipment's, alignment of shafts of rotating machinery, the slopes of all bearing pedestals, centering of rotors with respect to their sealing bores, couplings, etc. as applicable and the like items to ensure that no displacement has taken place during grouting. The values recorded prior to grouting shall be used during such post grouting checkup and verification. Such pre and post grout records of alignment details shall be maintained by the Contractor in a manner acceptable to the site Engineer of TSECL.

## 31 CHECK OUT OF CONTROL SYSTEMS

After completion of wiring, cabling, the contractor shall check out the operation of all control systems for the equipment furnished and installed under these specifications and documents.

## 32 CABLING

- 32.1 All cables shall be supported by conduits or cable trays run in air or in cable channels. These shall be installed in exposed runs parallel or perpendicular to dominant surface with right angle turn made of symmetrical bends for fittings. When cables are run on cable trays, they shall be clamped at minimum intervals of 2000 mm. or otherwise as directed by the site Engineer.
- 32.2 Each cable, whether power or control, shall be provided with a metallic or plastic tag of an approved type, bearing a cable reference number indicated in the cable and conduit list (prepared by the contractor), at every 5-meter run or part thereof and at both ends of the cable adjacent to the terminations. Cable routing is to be done in such a way that cables are accessible for any maintenance and for easy identification.
- 32.3 Sharp bending and kinking of cables shall be avoided. Installation of cables high voltage, coaxial, screened, compensating, mineral insulated shall be in accordance with the cable manufacturer's recommendations. Wherever cables cross roads and water, oil, sewage or gas lines, special care should be taken for the protection of the cables in designing the cable channels.
- 32.4 In each cable run some extra length shall be kept at a suitable point to enable one or two straight through joints to be made, should the cable develop fault at a later date.
- 32.5 Control cable terminations shall be made in accordance with wiring diagrams, using identifying codes subject to approval of Engineering charge of the work. Multi-core control cable jackets shall be removed as required to train and terminate the conductors. The cable jacket shall be left on the cable, as far as possible, to the point of the first conductor branch. The insulated conductors from which the jacket is removed shall be neatly twined in bundles



and terminated. The bundles shall be firmly but not tightly tied utilizing plastic or nylon ties or specifically treated fungus protected cord made for this purpose. Control cable conductor insulation shall be secure and even.

32.6 The connectors for control cables shall be covered with a transparent insulating sleeve so as to prevent accidental contact with ground or adjacent terminals and shall preferably be terminated at the connecting end of the equipment's. The insulating sleeve shall be fire resistant and shall be long enough to over pass the conductor insulation. All control cables shall be fanned out and connection made to terminal blocks and test equipment for proper operation before cables are corded together.

**33 AVAILABILITY OF SHUTDOWN.**

Such shut down will be provided by the Owner as per Owner's convenience on receiving written requisition informing about his programme from the contractor at least **one week** before such requirement. The Contractor shall have to arrange during execution everything necessary for complete installation & Commissioning of all equipment and the entire requirement as specified in the work schedule.

\*\*\*\*\*



**SECTION – V**  
**TECHNICAL SPECIFICATION**

**Technical Specification**

Sl no	Particulars
<b>A</b>	TUBULAR STEEL POLES FOR OVERHEAD LINES
<b>B</b>	PRE-STRESSED CONCRETE POLES' FOR OVERHEAD LINES.
<b>C</b>	100 KVA, 11/0.433 KV OUTDOOR TYPE ,3 PHASE POLE MOUNTED BIS CERTIFIED (LABEL-2) STACK CORE TYPE; ONAN COOLED; NON SEALED TYPE DISTRIBUTION TRANSFORMER. WITHOUT CSP FEATURE.
<b>D</b>	ALUMINIUM CONDUCTOR STEEL REINFORCED (ACSR) CONDUCTORS ,WEASEL", " RABBIT" and "DOG"" ACSR
<b>E</b>	M.S STRUCTURAL STEEL SECTION.
<b>F</b>	MILD STEEL, PAINTED ,STAY SET.
<b>G</b>	GI STAY WIRE SIZE 7/2.50 MM
<b>H</b>	8 S.W.G, M.S. HEAVY COATING GALVANISED IRON WIRE
<b>I</b>	11 KV AIR BREAK GANG OPERATED SWITCH (ROCKING TYPE: 2 POSTS, 200 A RATING) (FOR 11 KV A.C. SYSTEM (VERTICAL)
<b>J</b>	TECHNICAL SPECIFICATION FOR 12KV, 200A D.O. FUSE UNIT FOR 11KV A. C. SYSTEM (VERTICAL)
<b>K</b>	GAPLESS LIGHTNING ARRESTORS FOR 11 KV SYSTEM
<b>L</b>	11KV POLYMERIC PIN INSULATOR WITH PIN.
<b>M</b>	FITTING FOR DISC INSULATORS OF BALL & SOCKET TYPE.(3 NOS U BOLT TYPE)
<b>N</b>	11KV COMPOSITE POLYMERIC DISC INSULATOR (Ball & Socket Type)
<b>O</b>	EARTHING AND EARTHING PIPE.
<b>P</b>	DANGER NOTICE PLATE.
<b>Q</b>	L.T.SHAKLE INSULATOR.
<b>R</b>	L.T STRAPS & BOLTS
<b>S</b>	ISI MARKED 70mm <sup>2</sup> , 120mm <sup>2</sup> , 185mm <sup>2</sup> AND 240mm <sup>2</sup> PVC Cable
<b>T</b>	ISI MARKED 4mm <sup>2</sup> PVC Cable
<b>U</b>	Bi-METALLIC LUGS
<b>V</b>	LT & H.T STRAIN INSULATOR.
<b>W</b>	TECHNICAL SPECIFICATION FOR G.I. BARBED WIRE
<b>X</b>	M.S BLACK BOLTS , NUTS AND WASHERS.
<b>Y</b>	G.I WIRE CHAIN LINK SUB-STATION FENCING.
<b>Z</b>	19/33 KV XLPE insulated, Screened Power cable with Aluminum Conductor.
<b>Z1</b>	TECHNICAL SPECIFICATION FOR THE L.T AERIAL BUNCHED CABLES.



## A Tubular Steel Poles for Overhead Lines

1. **SCOPE:-** This specification covers the design, manufacture, testing at works, supply / delivery & transportation of Steel tubular Poles of length and quantities as specified in the “Work Schedule” conforming to IS:2713 (P-I & II)/1980 and as amended up to date with mild steel base plate circumferential welded at the bottom end of the pole. Pole are painted with red oxide primer on top and middle section of pole, conforming to IS:2074/1979 and hot dip galvanized on both inner and outer surfaces of the bottom section of the pole and base plate conforming to IS-4736-1986.
2. **STNDARDS:-** The Steel tubular Poles shall conform to the latest edition of Indian Standard Specification IS:2713 (P-I & II)/1980 or any other authoritative Standards(as amended upto date) except where specified otherwise in this Specification.
3. **CLIMATIC CONDITION / SERVICE CONDITIONS:** - The Steel tubular Pole to be supplied shall be suitable for satisfactory continuous operation under the flowing climatic conditions as per ISS:2713(P-I & II)/1980 and as amended latest.
  - i. Location : At various locations in Tripura.
  - ii. Max. ambient air temperature (Deg° C): 45
  - iii. Min. ambient air temperature (Deg° C): 4
  - iv. Max. yearly daily ambient air temperature (Deg° C): 40
  - v. Max average weighed average ambient temperature (Deg° C): 32
  - vi. Max. Altitude above mean sea level(meters): 1000 m.

### **4. SPECIFICATION FOR STEEL TUBULAR POLES AS PER ISS:2713 (P-I & II)/1980 & AS AMENDED LATEST.**

- 4.1. Manufacturer shall have valid BIS license for manufacturing of each category of Tubular Steel pole under the present scope of work.
- 4.2. The materials used in construction of tubular steel poles shall be of the tested quality of steels of minimum **Ultimate tensile strength 410 MPa (: 42 Kgf/mm2).**
- 4.3. For **Chemical test** each coil of sheet / strip used for manufacturing tubes shall be tested for phosphorus and Sulphur in accordance with IS: 228 (Part-III: 1972) and IS : 228 ( Part-IX) shall not show **sulphur and phosphorous contents of more than 0.060 percent each.**
- 4.4. Tubes for manufacturing poles shall conform to Grade Yst 240 of IS: 1161-1979 ‘Specification for steel tubes for structural purposes (third revision) . Manual metal arc welding process may also be used to make tubes so manufactured shall meet all the requirement of IS: 1161-1979. Cold bend test need not be carried out for tubes manufactured by manual metal arc welding.
- 4.5. Steel tubular Poles shall be of swagged and welded type. Swagged Poles shall be made of seamless or welded tubes of suitable lengths swagged and jointed together. No circumferential joints shall be permitted in the individual tube lengths of the poles. If welded tubes are used they shall have one longitudinal weld seam only and the longitudinal welds shall be staggered at each swagged joint.
- 4.6. Swagging may be done by a mechanical process. The upper edge of each joint shall be chamfer-ed if at an angle of about 45 degrees. The upper edge need not be chamfer-ed if a





circumferential weld is to be deposited in accordance with clause No.5.3.2 of IS: 2713(Part –I): 1980.

4.7. The length of joints on swagged Poles shall be in accordance with clause No.5.4 of IS: 2713(Part –I): 1980.

4.8. Poles shall be well-finished, clean and free from harmful surface defects. Poles shall be straight, smooth and cylindrical.

4.9. The manufacturer shall furnish a list of the major supplies effected during the last 3 (three) years indicating the volume of supply and actual delivery dates.

**4.10. Specific Technical Requirement for Tubular Steel Poles: Swaged Type.**

Sl. no	Parameters	8 meters long	9 meters long	11 meters long	12 meters long
1	Standard	IS:2713 (P-I & II)/1980 and as amended up to date with mild steel base plate			
2	Type of Pole	Swagged type Tubular Steel Poles made from Steel of Ultimate Tensile Strength of 410 Mpa (42 kgf/mm <sup>2</sup> )			
3	Designation	410:SP-15	410:SP-30	410:SP-56	410:SP-64
4	Overall length	8 meters	9 meters	11 meters	12 meters
5	Planting Depth	1.5 meters	1.5 meters	1.8 meters	2.0 meters
6	Load applied from top at a distance of (in meter)	0.30 meter	0.30 meter	0.60 meter	
7	Height above ground	6.5 meter	7.5 meters	9.2 meters	10.0 meters
8	Length of each section				
a)	Bottom (h3)	4.5 meters	5.0 meters	5.6 meters	5.8 meters
b)	Middle (h2)	1.75 meters	2.0 meters	2.7 meters	3.1 meters
c)	Top (h1)	1.75 meters	2.0 meters	2.7 meters	3.1 meters
9	Outside diameter & Thickness of each section (in mm)				
a)	Bottom	139.7 X 5.4	165.1 X 4.85	193.7 X 5.40	219.1 X 4.85
b)	Middle	114.3 X 4.5	139.7 X 4.5	165.1 X 4.5	193.7 X 4.85
c)	Top	88.9 X 3.25	114.3 X 3.65	139.7 X 4.5	165.1 X 4.5
10	Joint length (in mm.)				
a)	Bottom (J2)	300 mm	350 mm	400 mm	450 mm
b)	Top (J1)	230 mm	300 mm	350 mm	400 mm
11	Approximate weight of pole(excluding weight of Zinc)	119 Kg	154 Kg	241 Kg	292 Kg
12	Breaking load (in Kgf)	499	554	713	764
13	Crippling load (in Kgf)	354	393	502	342
14	Working load with factor of safety: 2.5 (in Kgf)	200	222	253	306
15	Load for permanent set not exceeding 13 mm (in Kgf)	243	269	347	371



16	Load for temporary deflection of 157.5 mm (in Kgf)	140	146	140	149
17	Tolerance	<p>i) Outside Diameter:- The outside diameters of the poles shall not vary from the appropriate value, except at the joint, by more than <math>\pm 1.0\%</math>.</p> <p>ii) Thickness:- In case of welded tubes, thickness shall not fall below the thickness specified by more than 10 percent.</p> <p>iii) Length:- The tolerance on the length shall be as follows: On the length of any section <math>\pm 40\text{mm}</math>. On the overall length of pole <math>\pm 25\text{mm}</math>.</p> <p>iv) Weight:- Mean weight for bulk supplies shall be within 92.5 percent of its calculated value. The weight of any single pole shall not fall below the nominal weight as given in Part-2 and Part-3 of IS: 2713 by more than 10 percent.</p> <p>v) Straightness :- The finished pole shall not be out of straightness by more than <math>1/600</math> of its length.</p>			
18	Finish & Manufacturing	IS:2713 (P-I & II)/1980 and as amended up to date.			
19	Base plate	<b>300mm X 300 mm X 6mm</b> made from MS Plate as per IS-2062			
20	Protection against corrosion	Pole are painted with red oxide primer on top and middle section of pole with two coats of red oxide primer (conforming to IS:2074/1979).and hot dip galvanized on both inner and outer surfaces of the bottom section of the pole and base plate.			
21	Galvanization of bottom portion i/c base plate.	<p>Galvanization of bottom portion i/c base plate will be done as per following standard-</p> <p>Zinc:- Zinc shall conforms to grade Zn 99.9 as specified in <b>IS: 209-1966.</b></p> <p>Zinc Coating:- Zinc coating shall be in accordance with <b>IS: 4736-1986</b></p> <p>Galvanization:- Galvanization shall be as per <b>IS: 2629-1985</b></p>			

**5. Earthing arrangements:-** Poles shall be provided with earthing arrangement with a thorough hole of 14 mm dia. which shall be provided at a height of 300 mm above the planting depth.

**6. M.S. Base Plate:-** M.S. base plate of size **300mm X 300 mm X 6mm** made from MS Plate conforming to IS-2062, shall have to be welded to bottom portion of the pole. Both planes of the plate to be welded along the circumference of the bottom portion of the pole.

7. **Top cap :-** Canopy shaped plate of thickness same as that of top section of the pole shall be provided at the top of the pole with proper welding.
8. The poles shall be made of welded tube of suitable length ( indicated in the relevant ISS and enclosed drawing) swagged together and conforming to chemical composition and physical requirement of the specification. The material to be used for the poles shall be of minimum tensile strength of 42 kg f per Sqmm.
9. **Chemical Composition:-** The materials, when analyzed in accordance with IS:228 (P-III:1972) and IS:228 (P-IX:1975) shall not show Sulphur and Phosphorous contents of more than 0.060% each.
10. **Minimum Tensile Strength :-** 410 Mpa / 42Kg/mm<sup>2</sup> (For all sizes of steel Tubular Poles)

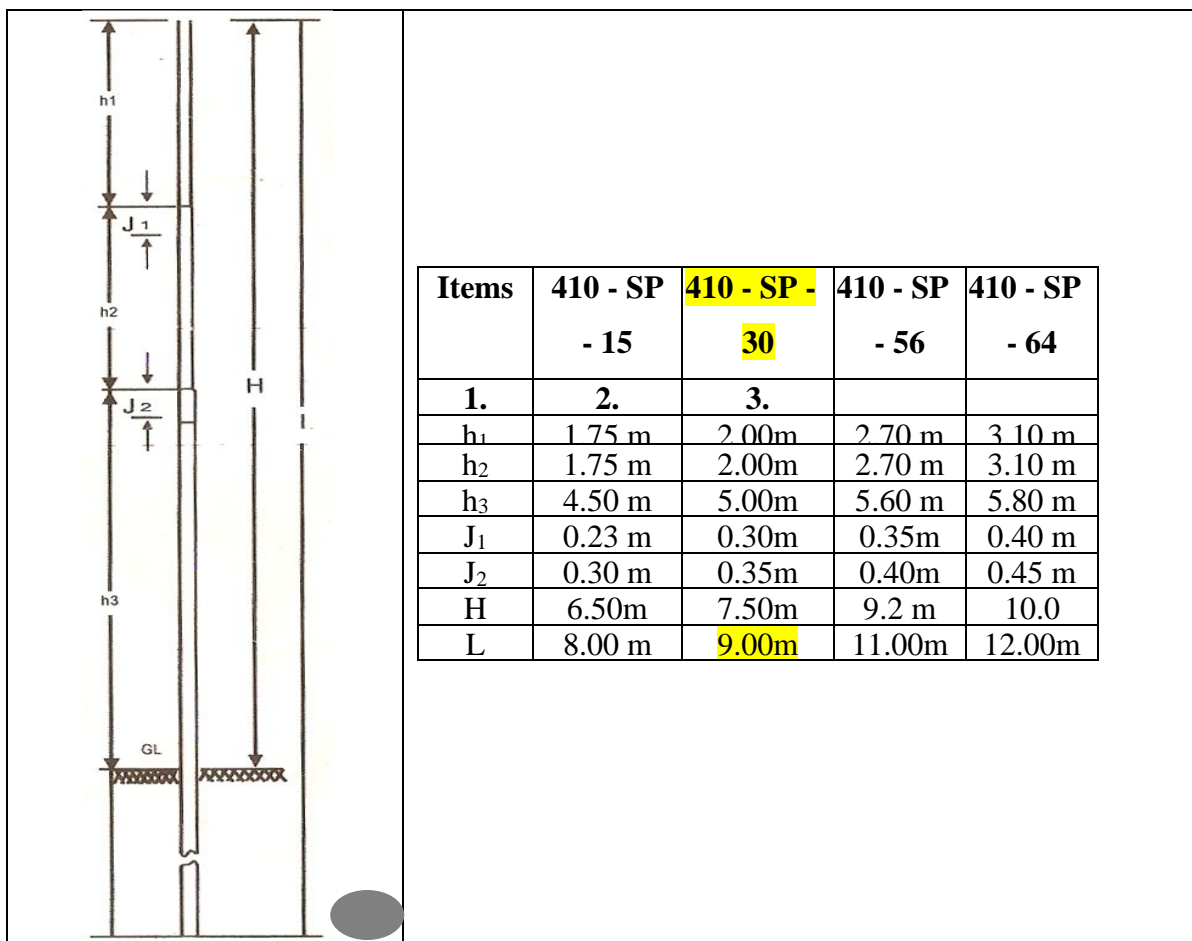

**Fig- 2 Steel Pole**

**11. TEST :-**

- 12.1. For **Chemical test** each coil of sheet / strip used for manufacturing tubes shall be tested for phosphorus and Sulphur in accordance with IS: 228 (Part-III: 1972) and IS : 228 ( Part-IX) shall not show **sulphur and phosphorous contents of more than 0.060 percent each**



- 12.2. The steel sample obtained from the finished pole when tested in accordance with IS: 1894-1972 shall show a minimum tensile strength of 410 M pa (42 Kg f/mm<sup>2</sup>) and a minimum percentage elongation specified in 10.1.1 and 10.1.1.1 of IS: 1161-1979.
- 12.3. Following tests shall be conducted on finished poles at the works of the manufacturer before delivery of each lot in presence of the representative of purchaser:
- Deflection test,
  - Permanent set test
  - Drop test, and
  - Physical verification of dimensions.
- 12.4. Above tests shall be conducted in succession on each of the pole selected, depending on lot size as follows:-
- | Lot size       | No. of poles |
|----------------|--------------|
| Up to 500      | 5            |
| 501 to 1000    | 8            |
| 1001 to 2000   | 13           |
| 2001 to 3000   | 18           |
| 3001 and above | 20           |
- 12.5. In addition to above verification of dimensions as per IS: 2713 (Part-III) : 1980 shall be carried out during acceptance of lots.
- 12.6. Number of poles selected for conducting different tests shall be in accordance to clause No. 10.1.1 and No. 10.1.12: of IS: 2713 (Part-I) 1980.
- 12.7. Tests shall be carried out before supply of each consignment at the manufacturers works and test certificates should be submitted to the purchaser for approval prior to delivery.
- 12.8. Re-tests, if any, shall be made in accordance with IS: 2713 (Part-I) 1980.
- 7.1. Purchaser reserves the right to inspect during manufacturing and depute his representative to inspect/test at the works.
- 12.9. If any extra cost is required for carrying out the above specified tests, the same shall be borne by the manufacturer.
- 12.10. Sample at random will be selected from the offered lot for the above testing and the lot will be accepted subject to compliance of the requirement of IS:- 2713 (Part-I)
- 12.11. **Notarized copy of Type test report of each category of Tubular Steel pole, from Central Govt/ NABL accredited lab to be submitted along with Part-I bid.**

## 12. INSPECTION

- 13.1. All test and inspection shall be made at the works of the manufacturer before delivery of each lot in presence of the representative of purchaser, unless otherwise especially agreed upon by purchaser. The manufacturer shall provide all facilities to conduct the required tests in accordance with specification. The Instruments provided at the works for testing & inspection must bear necessary Calibration certificate from Govt of India approved institution,
- 13.2. The purchaser reserves the right to have the test carried at the cost of the supplier by an independent agency whenever there is dispute regarding the quality of supply.

13. **PACKING & MARKING:-** Poles shall be well finished, clean and free from harmful surface defects. The steel Tubular Poles shall be so transported that the poles are adequately protected against damage in ordinary handling and transit.

14. **MARKING:-** Each pole shall bear the following permanent marking on a place just at the beginning of the middle section of the pole from bottom along the axis of the pole:



- a). Manufacturer's Name
- b). Manufacturer's Trade mark
- c) Designation of the pole
- d) "DWS-TSECL/2021-22"
- e) Year of manufacture
- f) **ISI certification mark (mandatory).**

**15. GUARANTEED TECHNICAL PARTICULARS:-** The guaranteed technical particulars of Steel Tubular Poles offered as per format given under SI no-18, shall be given by the bidder along with the tender.

**16. FOLLOWING TENDER ENQUIRY PROFORMA SHOULD BE DULY FILLED UP BY THE INTENDING BIDDERS:-**

**a) INFORMATION TO BE FURNISHED BY THE TENDERER FOR APPRAISAL OF FIRM'S CAPABILITY & CAPACITY TO MANUFACTURE ITEM (S) EQUIPMENT AS PER REQUIREMENT TO TENDER ENQUIRY**

- I. Name of the tendering Firm
  - II. Complete address of the required office
  - III. Telegraphic address
  - IV. Phone No.
  - V. Fax No.
  - VI. Email No.
- b) Production capacity per month of the item covered in your quotation and justification for assessment.**
- I. Details of plant & machinery installed  
(Please attached separate sheets, if necessary).
  - II. Details of raw material required.
  - III. Source of raw material.
  - IV. Stock in hand.
- c) Manufacturing process & quality control:-**
- I. Details of manufacturing process.
  - II. Scheme of quality controls
- d) Whether items offered conforms to IS or any other internationally recognized standards, if so, give reference.**
- e) Whether the firm is licensed to use ISI mark or any other Govt. Quality Mark. (Copies of latest test certificates issued by Govt. Laboratories/any Recognized Test House be attached).**

Signatory of the firm

Signature of Authorized

Seal of the firm



**f) DETAILS TESTING FACILITIES**

Name of Test Remarks	Detail of testing facilities available
-------------------------	--

- I. Test of Raw Materials
  - a) -----
  - b) -----
- II. Routine Test
  - a) -----
  - b) -----
- III. Acceptance Test
  - a) -----
  - b) -----
- IV. Type Test
  - a) -----
  - b) -----

Name of Firm .....  
 Name & Signature  
 of the tenderer .....  
 Designation .....  
 Date .....

Note : **In case, testing facilities are not available for certain test, indicate in remarks column from which testing house(S)/institution (s) these tests will be got carried out.**

**g) DETAILS OF TENDERER'S EXPERIENCE:-** Tenderer shall furnish here particulars of similar orders executed / under execution by him, to whom a reference may be made by Purchaser, in case such a reference is necessary.

Sl. No.	Name of the client and Description of order	Value of order In Rs.	Period of supply by the tenders against target	Name and address to whom reference may be made
1	2	3	4	5

- 1.
- 2.

Name of Firm .....  
 Name & Signature





of the authored signatory .....  
Designation .....  
Date .....

**17. Guaranteed & other technical particulars for 8m, 9m, 11 m & 12 mtr. Steel Tubular Poles**  
(To be furnished by the Manufacturer)

Sl.No.	Item	Description			
		8 mtr	9 mtr	11 mtr	12 mtr
1.	Make & BIS license				
2.	Place of Manufacture				
3.	Type of Poles				
4.	Designation of Pole				
5.	Outside Diameter of sections:- 1) Top (mm) ii) Middle (mm) ii) Bottom (mm)				
6.	Thickness of sections i) Top (mm) ii) Middle (mm) iii) Bottom (mm)				
7.	Tolerance i) Outside Diameter ii) Thickness ii) Length iv) Weight v) Straightness				
8.	Protection against corrosion:-				
9.	Earthing arrangements				
10.	M.S.Base Plate :-				
11.	Top cap :-				
12.	Minimum Tensile				
13.	Chemical Composition				
14.	Approx .Weight of				
15.	Breaking load of each				
16.	Crippling load of each				
17.	Marking as per clause No.5.2 of section-IV				

Signature of Authorized

Signatory of the firm  
Seal of the firm



## B Pre-stressed concrete poles'for Overhead Lines.

- 1.1 Scope of Work:-** Scopes of work covered under this package include Manufacturing, Inspection and testing at manufacturer's works and delivery and erection of the PCC poles as per the scope of the work & bearing the technical specification specified in the bid document.
- 1.2 Clearance for delivery of the PCC poles** under the scope of work will be issued by Engg. in Charge after successful Testing of the poles at works as per the delivery schedule. The PCC poles to be properly stored stack wise according to their categories, inside the factory complex and would be under watch & ward of the manufacturer.
- 1.3 Supplier of the PCC pole** must be a PCC Pole Manufacturer, registered under Directorate of Industries & Commerce, Govt. of Tripura and must have well equipped manufacturing, testing facilities & sufficient arrangement for lifting, loading/ un loading of poles. The manufacturing unit must have sufficient space inside the factory complex for storing of poles.

### 1.4 TECHNICAL SPECIFICATION.

- a) **Cement** : - The cement used in the manufacture of '**pre-stressed concrete poles**' shall be ordinary or rapid hardening Portland cement conforming to **IS: 269-1976 or IS: 8041-E.1976.**
- b) **Aggregate:-** used for the manufacture of Pre-stressed concrete poles (PCC poles) shall conform to **IS 383-1970. The stone chips to be used shall invariably be brought from outside Tripura State like Assam.** The nominal maximum size of aggregate shall in no case exceed **10mm.**
- c) **Water** : - Water should be free from chlorides, sulphate, other salts and organic matter.
- d) **Admixtures** : - Admixtures should not contain calcium chloride or other chlorides and salts which are likely to promote corrosion of pre-stressing steel.
- e) **PRE-STRESSING STEEL (i.e. TENSION WIRE)** : - The pre-stressing steel for works should conform to **IS: 6003 of 1983.** The diameter of pre-stressing steel wire shall be 4mm. with a **minimum ultimate tensile strength of 175kg. / mm<sup>2</sup>.**
- f) **CONCRETE MIX AND STRENGTH** : -

The concrete mixture shall be designed as per requirements below:

- I. **Minimum works cube strength of 28 days should be at least 250kg/cm<sup>2</sup>.**
- II. **The concrete strength at transfer should be at least 125kg/cm<sup>2</sup>.**
- III. The mixture should contain **380kg. to 510kg. of cement per cubic meter of concrete,** actual consumption will be determined by cube strength but the consumption in all cases will be based on 510 kg /cum.
- IV. The mixture should contain as low as water content as is constant with adequate workability.
- V. The concrete shall be compacted thoroughly by vibration, pressure, shock spinning or other means and shall have density of not less than 2.4 tones mm<sup>3</sup>. Hand compaction shall not be permitted and the required compaction shall be permissible by 'electric vibrator'.
- VI. The Concrete strength at transfer shall not be less than half the 28 days strength ensured in the design i.e.  $250 \times 0.5 = 125 \text{kg/cm}^2$ .



- g) **CURING** : - The concrete shall be covered with layer of soaking canvas, Hessian or similar absorbent materials and constantly wet up to the time when the strength of concrete is at least equal to the minimum strength of concrete at transfer of pre-stress. Thereafter, the pole may be removed from the mould and watered at intervals to prevent surface cracking of the unit. The intervals should depend on the atmospheric humidity and temperature.
- h) **The Pre-stressing wires shall be de-tensioned only after the concrete has attained the specified strength at transfer (i.e. 125kg/cm<sup>2</sup>).** The cube meant for the purpose of determining the strength at transfer (by cube test) should be cured, done for each incoming stock of cement as far as possible under conditions similar to those under which the poles are tested.
- i) **EYE-HOOK** : - Separate eye-hook shall be provided for handling and transportation, one each at a distance of 0.15 times the overall length from either end of the pole. Eye-hook should be properly anchored and should be on the face that has the shorter dimension of the cross-section. Stacking should be done in such a manner that the broad side of the pole is vertical. Each tier in the stack should be supported on timber sleepers located at 0.15 times the overall length measured from the end. The timber supports in the stack should be aligned in a vertical line.
- j) **EARTHING** : - Earthing shall be provided by having a length of 8-SWG, G.I. Wire embedded in concrete during manufacture and 150mm. ends of the wires should be left projecting from the pole at 250mm. from top and 150mm. below ground level. The earth wire shall not be allowed to come in contact with the pre-stressing wires.
- k) **SPECIAL TERMS & CONDITION.**
- a. The plans and Drawings connected with the work can be seen by the contractor before bidding for the job, which will be available in the O/O AGM(DP&C), Corporate Office, TSECL. The bidders are supposed to have acquainted themselves with the plan, design, drawing and specifications of the concerned work. No claim on this account will be entertained later on.
- b. It is also impressed upon the contractor that they will have to produce good workmanship strictly according to the specifications and no plea will be heard that they are not able to get good workers.
- c. It will be obligatory for the bidder to produce forest clearance certificate from the Divisional Forest Officer (DFO) having jurisdiction over the area in respect of extraction of any forest product for utilization in the works under this contract, before payment, and/or refund of security deposit, if the bidder fails to do so a sum of money towards the royalty, remaining paid by the contractor if any, as may be specified by the concerned Divisional Forest Officer will be set off from any of money including security deposit due and payable to the bidder under this contract.
- d. Tools & Plants will not be issued by the corporation.

**1.5 CALIBRATION OF TESTING INSTRUMENTS:** The instruments/equipment required for Inspection & Testing should have valid calibration as per following guideline:

- a) Calibration Certificate issued by Laboratory accredited by NABL may be accepted unconditionally provided the certificate bears an Accreditation body Logo.
- b) For Testing equipment s, where NABL Accreditation is not available, Calibration Certificate from Educational Institutions like IIT's, NIT's, J.U., C.U., BHU only can be accepted provided they can demonstrate traceability.



Necessary confirmation regarding above is to be given along with inspection offer failing which the inspection offer will not be accepted. **If during inspection & testing, the suppliers fail to produce Calibration Certificate as indicated above the offered lot may be rejected.**

## 1.6 INSPECTION & TESTING

### a) Before finalization of Tender:

After opening of Techno-Commercial part of the Tender, the tendering authority at its discretion may send their representative for inspection of the factory premises at any day within working hrs. to ensure participating tenderer's manufacturing capability & technical eligibility to combat with TSECL's requirement.

### b) After finalization of Tender:

I. Delivery of finished PCC pole from the contractor / manufacturer's works will only be permitted only after issuance of Materials Inspection Clearance Certificate (MICC) by the inspecting officer / team of TSECL unless otherwise waived by TSECL during execution of the contract in special circumstances.

II. **After** manufacturing and curing of the PCC poles, the contractor shall give intimation to the owner's Engineer in charge of the work for conducting inspection of PCC Poles / materials at manufacture's works or at recognized testing laboratories to be arranged by the contractor. **The intimation shall be made at least 15(fifteen) days before the PCC Poles / materials become ready for dispatch.**

III. TSECL may inspect the manufacturing process any time. The contractor shall give previous notice to the TSECL for the proposal / programme of testing. If considered necessary, the materials specially **H.T. wire** will be tested by **the inspecting officer / team of TSECL (Maximum two persons) at HT wire manufacturer's factory** before dispatch to the contractor's PCC Pole Manufacturing unit for which contractor will provide all sorts of arrangement for tests including to & fro travelling expenses, lodging charges etc for TSECL's representative at their cost. At least 2% of the total quantity shall be tested.

IV. **Testing** of PCC Poles, H.T. Wire / materials as specified above shall be conducted at the risk and cost of the contractor. **The contractor shall also bear the to and fro traveling and lodging charges of the inspecting officer / team of TSECL.**

### c) Acceptance test as per Technical Specification will be carried out at the works before delivery of the poles.

I. All the poles shall be tested for overall length, cross-section and uprightness. The tolerance shall be (+/-) **15mm. on overall length, (+/-) 3mm. on cross sectional dimension** and **0.50 % up-rightness**.

II. The number of poles to be tested for transfer strength test shall be **1(one) No. from each lot of 50 (fifty) Nos. Poles** .

III. Planting height of the pole shall be marked by putting paint at a height of **1.25mtr, 1.30 mtr. & 1.50 mtr.** from the bottom for **7.50 m. long, 8.00 m. long & 9.00 m. long** PCC Poles respectively.

IV. The poles shall be clearly indelibly marked with the following particulars during manufacture so as to easily read after erection position.

A) **Month and Year of Manufacture.**

B) **Transverse Strength of Pole in Kg.**

C) **Serial No. of pole & abbreviated name of firm.**



- V. **Responsibility of the contractor is in force till successful erection & commissioning of the PCC poles and any pole found defective during transportation of after erection & commissioning ,will have to be replaced at free of cost.**

**1.7 Details Specification of 9.0 mtr. /200 kg. Prestressed Concrete pole.**

1. Factor of safety ..... = 2.5
2. Concrete Grade ..... = M-250
3. Diameter of prestressing wire ..... = 4 mm.
4. Ultimate Tensile Strength of Prestressing Wire..... = 17500 Kg./cm<sup>2</sup>
5. Number of Tensile Wire ..... = 14
6. Number of Untensioned Wire..... = 2
7. Concrete Quantity per Pole..... = 0.203 m<sup>3</sup>
8. Steel Quantity per Pole ..... = 13.30 Kg.
9. Weight of Pole ..... = 490 Kg.
10. Clear cover to Wire..... = 20 mm.
11. Location of Holes: - As per REC Standard.
12. 'O' Denotes Tensioned Wire.
13. 'X' Denotes Untensioned Wire.
14. '+' possible position of Earth Wire.
15. All Dimensions are in mm.
16. Drawing not to Scale.

- VI. **NOTE:** For holding part length untensioned wires in position, 4mm stirrups may be use suitable spacing.If any practical difficulty is experienced in using part length untensioned wires, full length wires may be used instead. But the tension in these wires should not exceed their ultimate tensile strength value. However, it may be noted that use of part untensioned wires will be more economical.

**VII. Details Specification of 8.0 mtr. / 200 kg. Prestressed Concrete pole.**

1. F actor of safety..... = 2.5
2. Concrete Grade ..... = M-250
3. Diameter of prestressing wire..... = 4 mm.
4. Ultimate Tensile Strength of Prestressing Wire..... = 17500 Kg/cm<sup>2</sup>
5. Number of Tensile Wire..... = 14
6. Number of Un tensioned Wire..... = 2
7. Concrete Quantity per Pole..... = 0.157 m
8. Steel Quantity per Pole..... = 11.82 Kg.



9. Weight of Pole.....= 380 Kg.
10. Clear cover to Wire.....= 20 mm.
11. Location of Holes: - As per REC Standard.
12. 'O' Denotes Tensioned Wire. 13. 'X' Denotes Untensioned Wire.
13. 'X' Denotes Untensioned Wire.
14. '+' possible position of Earth Wire.
15. All Dimensions are in mm.
16. Drawing not to Scale.

VIII. **NOTE:**

1. For holding part length untensioned wires in position, 4mm stirrups may be used with suitable spacing.
2. If any practical difficulty is experienced in using part length untensioned wires, full length wires may be used instead. But the tension in these wires should not exceed their ultimate tensile strength value. However, it may be noted that use of part untensioned wires will be more economical.
3. The alternative of using full length wires instead of part length untensioned wire is not feasible if the pole is to be used for L.T. lines with vertical configuration. This is because of non-availability of sufficient clearance between the extended full length wires and the holes to be provided in the pole for fixing Shackle Insulators.



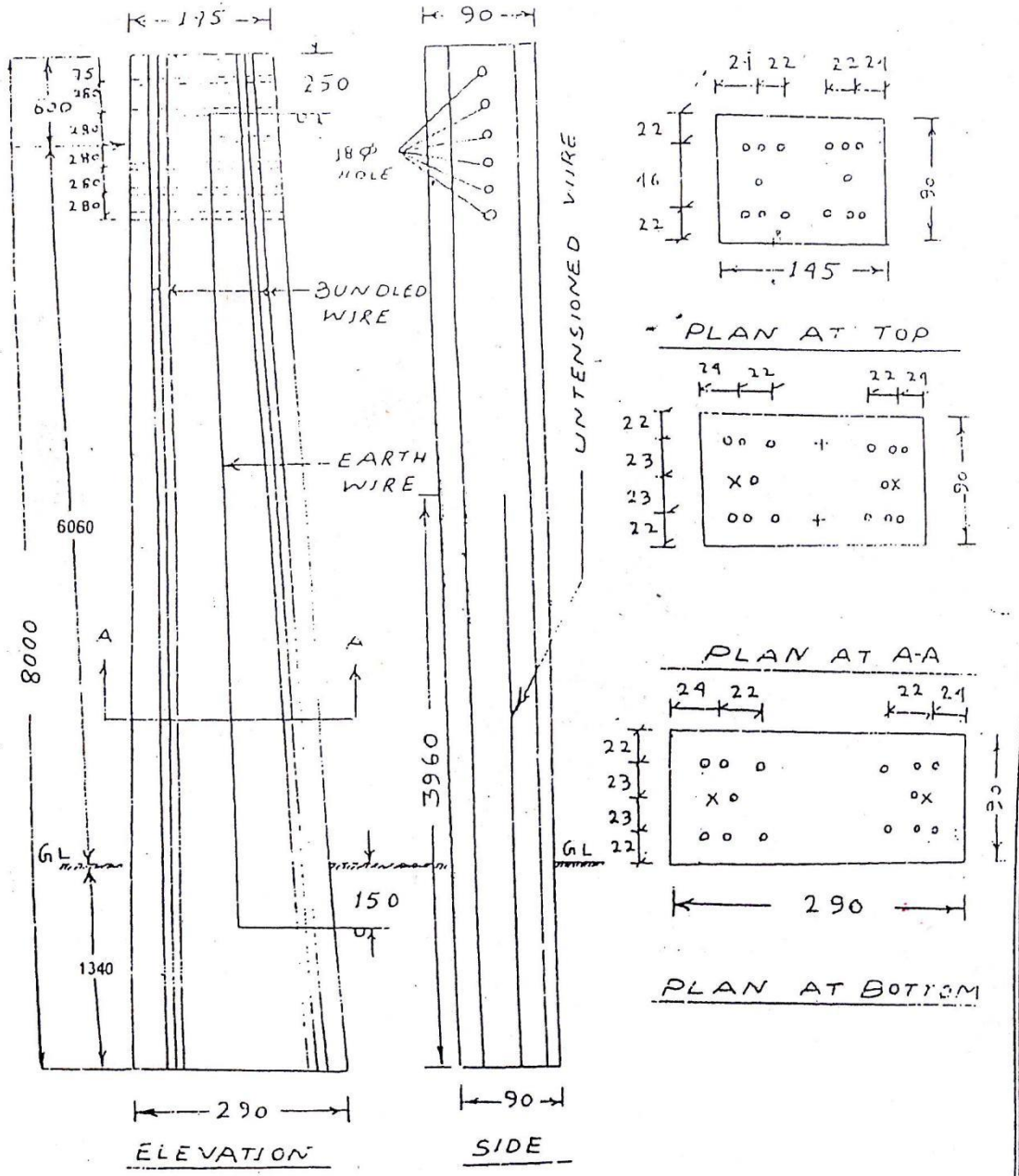

REINFORCEMENT DETAILS OF 8.0 M / 200 KG

PRESTRESSED CONCRETE POLE

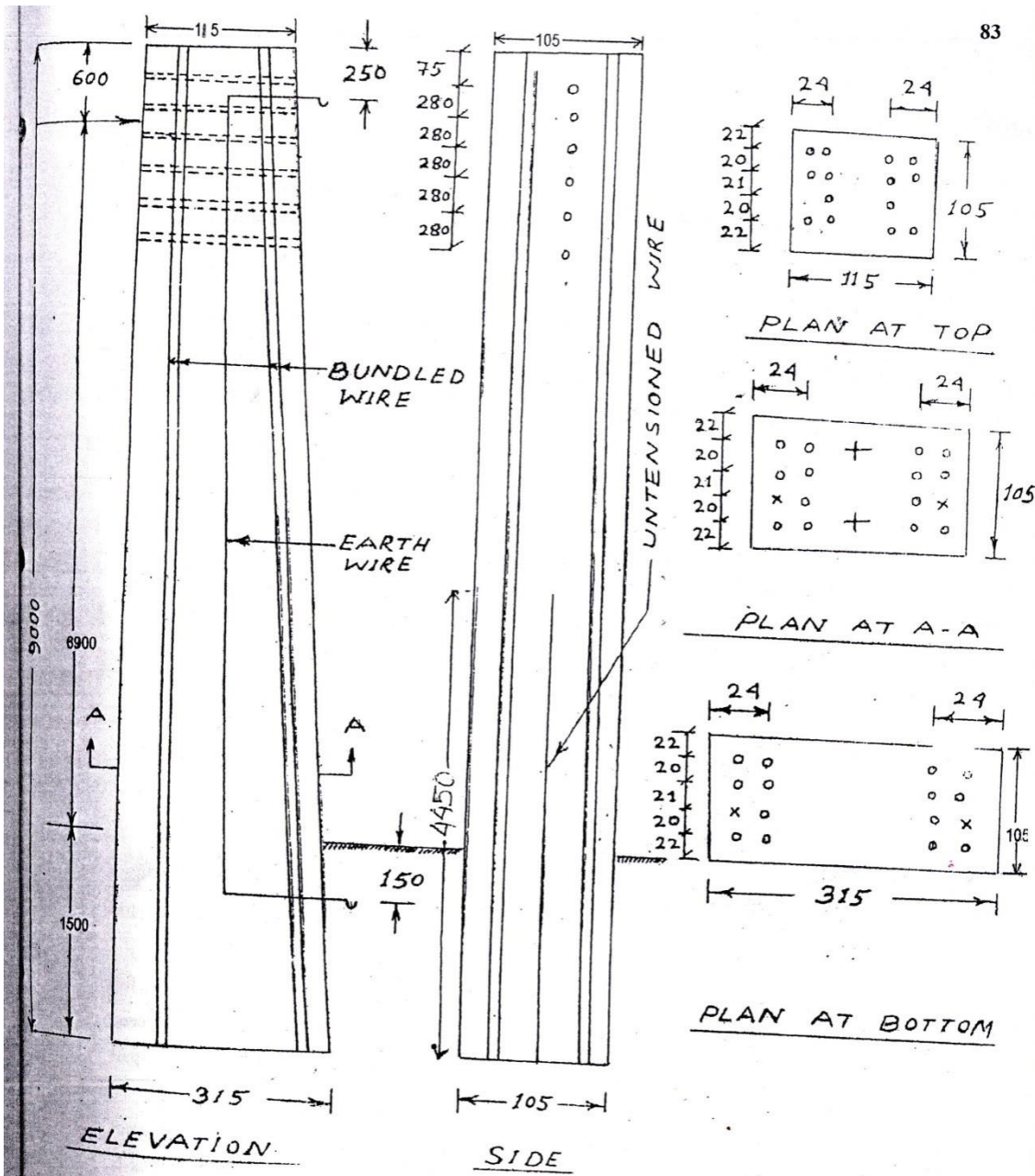

REINFORCEMENT DETAILS OF 9.0M/200Kg  
PRESTRESSED CONCRETE POLE



**C TECHNICAL SPECIFICATION OF 100 KVA, 11/0.433 KV OUTDOOR TYPE ,3 PHASE POLE MOUNTED BIS CERTIFIED (LABEL-2) STACK CORE TYPE; ONAN COOLED; NON SEALED TYPE DISTRIBUTION TRANSFORMER. WITHOUT CSP FEATURE**

**1.0 General:-**

**1.0 SCOPE:-**As per the Electrical Transformer (Quality Control) Order, 2014, it is mandatory that No Electrical Transformers shall be manufacture or store for sale, sell or distribute which do not confirm to the specified standard and do not bear standard Mark of the bureau, on obtaining certification mark license. Accordingly, the bidder shall have valid BIS license of the quoted item as per approved scheme of BIS. This specification covers design, engineering, manufacture, assembly, stage testing, inspection testing before supply and delivery at site and commissioning of oil immersed, naturally cooled 3 phase 11 kV/433 - 250 V distribution transformers (DT) of ratings 100KVA , BIS certified, Energy Efficiency Level-2 , three phase distribution transformers without CSP feature for outdoor use.. The transformers shall be double wound, three phase, CRGO M4/better Grade (0.27mm) or better, oil immersed with ONAN cooling with Oil filled up to maximum permissible level with Aluminum windings.

**1.1. The DTs** shall conform in all respects to high standards of engineering, design and workmanship and shall be capable of performing in continuous commercial operation, in a manner acceptable to the purchaser, who will interpret the meanings of drawings and specification and shall have the power to reject any work or material which, in his judgment is not in accordance therewith. The offered equipment shall be complete with all components necessary for their effective and trouble free operation. Such components shall be deemed to be within the scope of bidder's supply irrespective of whether those are specifically brought out in this specification and / or the commercial order or not.

**1.2. CLIMATIC CONDITIONS:** The Distribution Transformers to be supplied against this Specification shall be suitable for satisfactory continuous operation under the following climatic conditions as per 1180(Part-I): 2014 or latest revision.

a	Elevation at mean sea level	1000M
b	Maximum ambient Air temperature(°C)	50
c	Maximum daily average ambient(°C)	40
d	Minimum Ambient air temperature (°C)	5
e	Relative humidity	95%
F	Pollution level	Moderately poluted
G	Maximum Wind Pressure	250 kg/sq. mtr
H	Annual average rain fall	3000mm
i	Average No. of thunder storm day per annum:	100



**1.3. APPLICABLE STANDARD:-** The transformers covered by this specification shall, unless otherwise specified be built to confirm to the latest Indian Electricity Rules, wherever applicable and the requirements of the latest issues of IS: 1180(Part-I) of 2014 and IS:2026, CBIP Standards and other ISS(All as per latest issues ) some of which are as stated below:

Sl.No	Item	Order / IS Number
1.	Specification for Power Transformer	IS:2026
2	Outdoor / Indoor Type oil immersed Distribution Transformers upto & including 2500 KVA, 33 KV - specification	Electrical Transformers (Quality Control) Order, 2014 and IS 1180(Part-1) of 2014 with upto date amendments
3.	Specification for Cold Rolled Grain Oriented Electrical Steel	IS:3024
4.	Specification for Aluminium wire rods	IS:5484
5.	Paper covered aluminium conductors Round conductors	IS: 6162 (Part 1): 1971
6.	Rectangular conductors	IS: 6162 (Part 2): 1971
7.	Cellulosic papers for electrical purposes:	IS:9335 (Part 1): 1979
8.	Methods of test	IS:9335 (Part 2): 1998
9.	Specifications for individual materials, Section 1 General purposes electrical paper	IS:9335 (Part3/Sec1):1984
10.	Specifications for individual materials, Crepe paper	IS:9335 (Part3/Sec3):1984
11	Specifications for individual materials, Special paper	IS:9335 (Part3/Sec5):1985
12.	Specification for Press Board	IS:1576
13.	Specification for Transformer/Mineral Oil	IS:335
14.	Specification for Upto 1.0 KV Bushing	For Porcelain Part-IS:3347(Part-I/Section-I) For Metal Part-IS:3347(Part-I/Section-II)
15.	Specification for 17.50 KV Bushing	For Porcelain Part-IS:3347(Part-III/Section-I) For Metal Part-IS:3347(Part-III/Section-II)
16.	Specification for Marking and Relative positions of terminals	IS:2026 (Part-I)
17.	Specification of Gaskets	Type-III as per IS:11149/Type-C as per IS:4253(Part-II)
18.	Specification for colours for ready mixed paints	IS 5
19.	Specification for ready mixed paint, brushing Zinc Chromate, priming	IS 104
20.	Testing for steel sheets and strips and magnetic circuits	IS 649
21.	Guide for loading of oil immersed Transformers	IS-6600
22.	Specification for Mechanical testing of metals- Tensile Testing.	IS 1608:2005
23.	Determination of water content in oil for porcelain	IS-2362



	bushing of transformer	
24.	Electrical Power Connector	IS-5561
25.	Determination of electrical strength of insulation oil	IS-6792
26	Installation and Maintenance of Transformer.	IS-10028

**1.4. Pre-qualifying requirements of Distribution Transformer.**

Serial No	Requirements	Documents required to be submitted
1	BIS License	(i) Supply of 25, 63, 100 & 200 KVA (aluminum wound & CRGO Core) rating distribution transformers, is open to those manufacturers only, who possess valid ISI License/ Marketing rights as per BIS for offered ratings for energy efficiency level-II as specified in IS:1180 (Part-I):2014. (ii) <b>ISI marking-</b> The transformer, as per Energy Efficiency Level-2 specified in IS-1180(Part-1):2014, must bear 'ISI' certification mark. In this connection, a certified photocopy of the valid ISI license/marketing rights must be submitted along with the tender. (iii) In absence of ISI marking License, the offer shall be liable for rejection.
2	Type test report for tendered rating of transformers.	(i) <b>The certified photo copies of valid type &amp; special test Reports required for 'ISI' mark i.e for obtaining manufacturing license from BIS authorities, losses as per Energy Efficiency Level-2 specified in IS-1180(Part-1):2014, Aluminum wound- 25 KVA, 63 KVA, 100kVA and 200 KVA rating distribution transformer (Aluminium wound &amp; CRGO Core) from the Govt. Standard test Laboratory/Govt. Approved Laboratory shall be submitted along with the tender.</b> (ii) <b>The type test certificates for all ratings shall not be more than 5 years old from the date of opening of the tender.</b>

**1.5. Application:-**The equipment shall be installed on double pole structure or plinth at outdoor location in Tripura in the Distribution system of TSECL L to effect power supply to the consumer.

**1.6. Guarantee :-** The Distribution Transformers, shall be guaranteed for a period of **36 months from the date of receipt at site or 24 months from the date of commissioning, whichever is earlier.** The materials found defective within the above guarantee period shall be repaired / replaced by the supplier free of cost within three month of receipt of intimation. If the defective materials are not repaired/ replaced within the specified period, the purchaser shall recover an equivalent amount plus 15 % supervision charges from any of his bills or from the performance guarantee deposit.

**1.7. Principle Parameters:-** The transformers shall be suitable for outdoor installation with three phase, 50 Hz, 11 KV system in which the neutral is effectively earthed and they should be suitable for service with fluctuations in supply voltage upto plus 12.5% to minus 12.5%. 4.02 The Transformer shall conform to the following specific parameters

1.	Nominal System Voltage	121KV
2.	Minimum Basic Insulation	75 KV <sub>p</sub>





	Level	
3	No load Voltage Ratio	11,000/433-250 V
4.	Phase	3 Phase
5.	Frequency	50 HZ subject to fluctuation of + 5%
6.	Connection HV	Delta
7a	Connection LV	Star ( Neutral brought out)
7 b	LV Neutral Earthing	The Neutral point of the secondary (LV) winding shall be brought out in a separate insulated terminal and shall be solidly earthed.
8.	Vector Group	Dyn11
9.	Type of Core	High Grade CRGO material (Stack Core)
1 0	Winding	Both HV and LV winding shall be wound from Double paper Covered aluminium conductor conforming to IS- 6162 (Part 1) & (Part-II) 1971
1 1	Rating	25 , 63, 100 & 200 KVA
1 2	Type of Cooling	ONAN
1 3	Percentage Impedance at 75°C	4.5% ± 10% (IS tolerance)
1 4	Maximum Temperature Rise over ambient	i) Top oil temp. rise measured by thermometer - “35°C” ii) Winding temp. rise measured by resistance method – “40 °C”
<b>Bids not meeting the above limits of temperature rise will be treated as non responsive.</b>		
1 5	Rated Short Circuit Level	13.1 KA for 3 seconds at 11 KV
1 6	Taps	No tapping shall be provided for transformers upto 200 KVA rating, until and unless specified.
1 7	Audible sound levels in decibel at rated voltage & frequency	i) Upto 50 KVA 48db ii) 51 – 100 KVA – 51db iii) 101 – 300KVA – 55 db iv) 301 – 500KVA – 56 db. ii) 51 – 100 KVA – 51db
1 8	Type	Non-Sealed Type

**1.8. Winding Connections and Phase displacement :**The primary winding's of the transformers shall be connected in delta and the secondary winding's in star vector symbol, Dyn-11], so as to produce , a positive phase displacement of 30° from the primary to secondary vectors of the same phase. The neutral of the secondary winding shall be brought out to a separate insulated terminal.

**1.9. Taps :**No tapings shall be provided for transformer upto & i/c 200 KVA rating.

**1.10. LIMITS OF TEMPERATURE RISE:-**The type of cooling shall be ONAN as per IS:2026 (Part-2). The permissible temperature rise shall not exceed the limits of when measured by resistance method for transformer winding and measured by thermometer for top oil when tested in accordance with IS: 2026(Part-2) :

KVA Rating	for transformer winding (when measured by resistance method)	for top oil (by thermometer)
Upto & i/c 3-ph 200 KVA	40°C	35°C





## 2.0 DESIGN AND CONSTRUCTION :

- 2.1. Core : Material : CRGO Sheet** The core shall be of NEW high grade cold rolled grain annealed steel lamination having low loss and good grain properties, coated with hot oil proof insulation, bolted together and to the frames firmly to prevent vibration or noise. **All core clamping bolts, MS hard wares etc. inside the tank shall be effectively insulated** The complete design of core must ensure permanency of the core losses with continuous working of the transformers. The maximum flux density in any part of the core and yoke at normal voltage & frequency shall be such that the flux density with +12.5% combined voltage and frequency variation from rated voltage & frequency does not exceed 1.9 Tesla.
- 2.2.** The No Load Current at rated voltage and frequency shall not exceed 3% of the full load current and at 112.5% combined variation of voltage & frequency the no load current shall not exceed 6% of full load current.
- 2.3.** The assembled core shall be securely clamped with uniform pressure to minimize noise.
- 2.4.** The M.S. The core clamping frame shall be provided with lifting eyes for the purposes of tanking and un-tanking of the live parts of the transformer. The whole core shall be electrically connected by copper strip of adequate section to the core frame at two separate points for being eventually earthed through the tank to drain off electrostatic potential that may built up..
- 2.5.** The supporting framework of the core shall be so designed, so as to avoid the presence of pocket which would prevent complete emptying of tank or cause trapping of air during filling. Core top and bottom of yoke shall be supported with M.S. Channel of proper size and Properly bolted together for stack type core.
- 2.6.** Adequate provision shall be made to prevent movement of core and winding relative to the tank during transport and installation or while in service. 7.07 The core shall conform to: IS : 3024, Electrical sheet steel & IS : 649, Method of test steel sheet . Successful bidder will offer for core for inspection and / or approval by the purchaser during the manufacturing stage. All channels, top and bottom yoke, Nut Bolts, Tie rods shall be painted with oil and corrosion resistant paint before use.
- 2.7.** The manufacturers call notice in this regard should be accompanied with the following documents as proof towards the use of prime core material.
- 2.8.** 1) In voice of the supplier 2) Mill's test certificate 3) Packing list 4) Bill of Landing 5) Bill of entry certificate to customs .
- 2.9.** Core material shall be procured either from core manufacturer or through their accredited marketing organization of repute. 7.09 Transformer Sl. No. shall have to be punched on the top core - yoke frame.
- 2.10.** MS Channels shall be painted with varnish or oil-resistant paint.
- 2.11.** Top & bottom yoke should be constructed as per drawing & design of the manufacturer but the core losses & magnetizing current should be guaranteed.
- 2.12.** The cores shall conform to IS: 649 ( testing for steel sheets & strips & magnetic circuit).
- 2.13. INSULATION LEVEL :** The Transformer shall be capable to withstand test voltage as specified below:

Nominal voltage	Highest System voltage	Rated impulse voltage	Lightning withstand ( In KV	Rated power withstand voltage in KV	short duration frequency
-----------------	------------------------	-----------------------	-----------------------------	-------------------------------------	--------------------------



		peak)	( r.m.s)
<b>11 KV</b>	<b>12 KV</b>	<b>75</b>	<b>28</b>
<b>433 V</b>	-	-	<b>3</b>

**2.14.** The transformer core shall not be saturated for any **value of V/f ratio** to the extent of 112.5% of the rated value of V/f ratio (**i.e. 11 KV/50 due to combined effect of voltage and frequency**) upto 112.5% on any tapping without injurious heating at full load condition and will not get saturated. The supplier shall furnish necessary design data in support of this situation.

**2.15. Flux Density :**The maximum flux density in any part of the core and yoke at normal voltage & frequency shall be such that the flux density with +12.5% combined voltage and frequency variation from rated voltage & frequency does not exceed 1.9 Tesla. The vendor shall furnish necessary design data in support of this stipulation. Tenderer should submit Maximum flux density & Core-weight calculation sheet.

**2.16. No load current :**No load current at rated voltage and at 112.5% of rated voltage shall not exceed the values given below:

KVA Rating	Percentage of rated full load current	
	At 100 % rated voltage	At 112.5 % rated voltage
Upto & i/c 3-ph 200 KVA	3% of Full load current.	6% of Full load current
Higher than 200 KVA upto & i/c 3-ph 2500 KVA	2% of Full load current.	5% of Full load current

**2.17. Terminals:** Transformer shall be provided with bare outdoor type bushing insulators on both H.V. & L.V. Sides. HV & LV bushings shall be located on opposite side of the transformer, not on the Top Cover. The Height of the top of the Bushing should be below the minimum oil level marking of the oil level gauge in case of transformer with conservator ( i.e 63 & 100 KVA ). The inner end of H.V bushing i. e portion of H.V bushing within the Bushing pocket should be below minm oil level marking in case of 25 KVA DTR. **L.V bushing location should be well above the top yoke.** The electrical characteristic of bushings insulators shall be in accordance with the latest version of IS 2099. Dimensions & type of bushing shall conform to IS: 3347 & shall be as follows : H.V. Bushing (11 KV Side) : 17.5 KV class LV bushing (0. 433 KV side) : 1100 V Class Neutral bushing at L.V. Side : Neutral of L.V. Winding shall be brought out through porcelain bushing similar to LV bushing for connection with earth terminal.

(i) **Brass** rods of **12 mm** dia. **for H.T.** with necessary Nuts, check nuts and plain thick tinned washers.

(ii) **L.T. terminal** shall be manufactured with necessary nuts, check nuts and plain thick tinned washers in accordance with relevant IS with latest amendment.

### 3.0 Winding :

**3.1. Current Density for HV & LV should not be more than 2.8 A/mm<sup>2</sup> for copper and 1.6 Ampere per mm<sup>2</sup> for Aluminium Conductor.**

3.2. The Transformer shall be provided with requisite number of winding's and shall be so designed to withstand the electro-mechanical stress exerted under short circuit conditions as per ISS : 2026 (Part-5)

3.3. The winding shall be so designed to reduce to a minimum out of balance forces in the transformer. Foil winding will not be acceptable



- 3.4. The winding shall be so designed that all coil assemblies of identical voltage & KVA rating shall be Interchangeable.
- 3.5. The winding shall be assembled on the core centrally for magnetic balance & symmetrically for electrical balance. Ducts shall be provided for oil circulation and lowering hot spot temperature in the winding.
- 3.6. All insulating materials to be used in the transformer shall be of Class A insulation as specified in Indian Standards. The paper insulation where used shall be epoxy dotted craft paper and shall be dry and free from puncture and other defects. Solid insulation shall be of best quality. Wooden support, if used, shall be well seasoned and compatible with hot transformer oil The test certificate of the raw materials shall be made available by the Transformer manufacturer on request during Inspection & Testing
- 3.7. The insulation of Transformer winding & connections shall be free from Insulating materials liable to soften, ooze out , shrink or collapse and shall be non catalytic & chemically inactive to transformer oil during service.

**3.8. The details Insulation covering for L V conductors and HV winding shall be DPC ( Double Paper Cover) for 16, 25, 63, 100 & 200 KVA.**

- 3.9. The number of HV coils per phase per limb for stack core shall be minimum 4(four) nos. up to 63 KVA DTR , 6(Six) nos. for 100 & 200 KVA DTR .
- 3.10. The Inter-leaved Insulating paper between the layers of the winding , shall be epoxy dotted Kraft Paper
- 3.11. The clearance between the coils shall be adequate and well co - coordinated.
- 3.12. The stacks of winding's shall receive adequate pre shrinkage treatment before assembly. No tapping are to be provided on the winding.
- 3.13. HV / LV lead termination to the stud should be made either by method of brazing / soldering or the free end of The lead wire having considerable length should be bent to form a ring & the ring should be fixed to the bushing stud with suitable nut , bolt and washer.
- 3.14. The neutral formation point inside the tank should be at a suitable location on the upper portion of the tank and not on the lower side so that it is easily accessible without lifting the core coil assembly.

**4.0 WINDING AND CLEARANCE INSIDE THE TANK ( For Stack type core )**

- 4.1. **Construction** : The winding shall be assembled on the core co-axially for magnetic balance and symmetrically for electrical balance. Liberal ducts shall be provide for oil circulation and lowering hot spot temperature in the winding. Spacers, wedges shall be robust & hard insulation's are so fitted in the winding that they will neither move, nor permit any relative movement of any part of the winding during normal service and under a terminal short circuit, without causing mechanical injury to any insulation in the winding.
- 4.2. The transformer shall have separate H.V. and L.V. Winding's made of electrical grade Aluminium wires as specified conforming to relevant ISS i.e. IS:191. IS:1897, IS:7404, IS: 12444, IS:13730 & IS:6162 of latest edition.
- 4.3. Number of HV coils per phase/limb shall not be less \than 4 nos for DTR of rating 25 & 63KVA and for 100 KVA &200KVA transformer the no of HV coils per phase/limb shall be minimum 6 Nos.
- 4.4. Minimum clearance between HV coils and/or sections should be 6.4mm and at top/bottom, the minimum clearance should be 12 mm including 1.5 mm insulating ring.
- 4.5. Minimum inter phase clearance (HV to HV) with 3 mm phgase barriers should be 10 mm up to voltage class of 12 KV.
- 4.6. The minimum end clearance (HV to earth) should be 20mm up to voltage grade 12 KV.
- 4.7. End installations at both ends shall include upto 360 KV grade:-
- 4.8. 3mm thick yoke insulation over winding of the phases.
- 4.9. 6mm ducts at the top and bottom for circulation of oil in the LV and HV winding's.
- 4.10. The minimum radial clearance in the winding will be as follows:-
- 4.11. Between core & LV winding 3 mm.



- 4.12. Between LV winding and HV winding 10mm including 2.0 mm thick pressboard conforming IS:1576 cylinder where LV winding is 1100V grade and HV winding 12 KV grade.
- 4.13. LV cylinder preferably be made of corrugated insulating press board. Oil ducts need to be provided between core and LV winding.
- 4.14. Minimum clearance between tank wall and HV winding's/live parts, where the HV winding is 12 KV grade,
- 4.15. **Clearance:** 25 mm no additional insulating barrier shall be used in between. The dimension in respect of ducts and clearance in the winding's shall hold for the assembled winding's and core prior to application of pressure for permanent shrinkage of coils. The changes in dimensions in finished condition shall remain within 15% (Fifteen percent).
- 4.16. The stack of winding shall receive adequate shrinkage treatment before final assembly. Adjustable devices shall be provided for taking up any possible shrinkage of coils in service. The coil clamping arrangement and finished dimensions of any coil duct shall be such as will not impede free-circulation of oil through the ducts.
- 4.17. All spacers, Axial wedges/runners used in winding's shall be made of pre-compressed press board – solid, conforming to B 3.1 of IEC 641-3-2. In case crossover coil winding of H.V. all spacers shall be properly sheared and dovetail punched to ensure proper locking. All axial wedges/runners shall be properly milled to dovetail shape so that they pass through the desired spacers freely. Insulation shearing, cutting, milling and punching operations shall be carried out in such away, that there should not be any burr and climatic variations.

### 5.0 Bracing of Winding's :

- i. The winding's and connections shall be braced to withstand shocks which may occur during transport or due to switching / short circuit and other transient conditions during service.
- ii. Coil clamping rings, if provided, shall be of steel or of suitable insulating material. Axially laminated material other than Bakelite paper shall not be used.  
Transformer shall be provided with the requisite number of winding's and shall be designed to withstand the electro-mechanical stress exerted under short circuit conditions as per ISS: 2026 – 1977.
- iii. Class 'A' insulation shall be used. Paper insulation shall be dry and uniform and free from punctures and other defects. Solid insulation shall be of best quality. Wooden supports, if used, shall be well seasoned and compatible with hot transformer oil. The test certificate of the raw materials shall be made available by the transformer manufacturer on request during Inspection & Testing.
- iv. The winding shall be so designed to reduce to a minimum the out of balance forces in the transformer at all voltage ratings.
- v. The winding shall also be designed such that all coil assemblies of identical voltage rating shall be interchangeable and repairing of the winding can be made readily without special equipment's.
- vi. The winding shall be so designed to reduce to a minimum the out of balance forces in the transformer at all voltage ratings.  
The winding shall also be designed such that all coil assemblies of identical voltage rating shall be interchangeable and repairing of the winding can be made readily without special equipment's.

### 6.0 Losses and Impedance:

- 6.1. The bidder should guarantee individual no-load and load loss without any positive tolerance. The bidder should also guarantee the total losses at 50% and 100% load condition (at rated voltage and frequency and at 75° C without any positive tolerance).

Rating in KVA	Maximum Total Losses (in watts) at		Impedance (%) at 75° C
	50 % Loading	100 % Loading	
<b>16</b>	<b>135</b>	<b>440</b>	<b>4.5%</b>



<b>25</b>	<b>190</b>	<b>635</b>	<b>4.5%</b>
<b>63</b>	<b>340</b>	<b>1140</b>	<b>4.5%</b>
<b>100</b>	<b>475</b>	<b>1650</b>	<b>4.5%</b>
<b>200</b>	<b>780</b>	<b>2300</b>	<b>4.5%</b>

**6.2. No Positive tolerance shall be allowed on the maximum losses displayed on the label for both 50% and 100 % loading values. . In case, the actual loss values exceed the above guaranteed values, the transformers shall be rejected at the risk, cost and responsibility of the supplier. The bidder should guarantee individual No load losses & Load loss without any positive tolerance. The values guaranteed in G.T.P. for flux density, no load current at rated voltage, no load current at 112.5% of rated voltage and no load loss at rated voltage shall be individually met.**

**7.0 Clearance inside the tank (for stack type core construction):**

<b>7.4.0 Insulation material and Clearance:</b>					
Sl no	Particulars	KVA ratings			
		25	63	100	200
7.4.1	Radial clearance of LV coil to core (bare conductor) shall not be less than	3.5 mm	3.5 mm	4.0 mm	4.0 mm
7.4.2	Radial clearance between HV & LV shall not be less than	11 mm	11 mm	10.0 mm	10.0 mm
7.4.3	Phase to phase clearance between HV conductor shall not be less than	11 mm with the minm of 2 x 1 mm press board to cover the rods.	11 mm with the minm of 2 x 1 mm press board to cover the rods.	10.0 mm	10.0 mm
7.4.4	Minimum electrical clearance between the winding and body of the tank (between inside surface of the tank and outside edge of the windings) should be	30 mm	30 mm	30 mm	30 mm
7.4.5	Minimum end insulation to earth shall be	25 mm	25 mm	25 mm	25 mm
7.4.6	No. of coils HV & LV / phase (minimum)				
	HV =	4 nos	4 nos	4 nos	6 nos
	LV =	1 no	1 no	1 no	1 no
7.4.7	Minimum thickness of locking spacers between HV coils	10 mm	10 mm	10 mm	10 mm
7.4.8	No. of axial wedges between LV and HV winding equal-spaced around LV	6 nos	6 nos	8 nos	8 nos
7.4.9	Minimum external clearances of Bushing terminals				



HV : Phase to Phase =	255 mm	255 mm	255 mm	255 mm
HV : Phase to Earth =	140 mm	140 mm	140 mm	140 mm
LV : Phase to Phase =	75 mm	75 mm	75 mm	75 mm
LV : Phase to Earth =	40 mm	40 mm	40 mm	40 mm

## 8.0 TRANSFORMER TANK

- 8.1. **Construction** :- Conventional plain tank shall be constructed. The Transformer tank and cover shall be fabricated from good commercial grade low Carbon Steel suitable for welding & of adequate thickness. The tank wall should be of thickness **3.15 mm. Top and bottom plate should be of 5.0 mm thickness for transformers upto and including 100 KVA and for transformers above 100 KVA rating it shall be of minimum 6.0 mm. thickness for tank top & bottom plate and for side wall it the thickness shall be of minimum 4.0 mm. thickness.** Tolerance as per IS : 1852 shall be applicable.
- 8.2. Tank design shall be such that core & winding assembly can be tanked or de-tanked easily.
- 8.3. The under carriage of the tank shall be made of channel of suitable size & design.
- 8.4. The base of each tank shall be so designed that it shall be possible to move the complete transformer unit by skidding in any direction without injury when using plates or rails.
- 8.5. Tank shall be designed to prevent retention of water. Tank cover shall be of adequate strength. It shall be bolted on to flanged rim of the tank with weather proof hot oil resistant Synthetic rubber or synthetic rubberized cork resistant to hot transformer oil conforming to Type III as per IS 11149/Type C as per IS 4253(Part2)of 5 mm thickness and shall be provided with water tight compound between the tank flange and the gasket.
- 8.6. Horizontal Stiffer shall be provided continuously welded on the tank wall. Vertical stiffener of similar 9.07 For 63, 100 & 160 KVA DTR thermometer pocket should be welded on tank top cover having threads on projected portion above top cover so that the pocket can be covered by a metallic cap having thread inside. The location of the thermometer pocket should be at the centre of the tank top cover.
- 8.7. For 25 KVA DTR a oil filling hole with threaded metallic cover should be provided at the centre of the tank top cover. 9.09 Lifting lugs are to be provided at the two diagonally opposite sides of the tank top cover so that the finished transformer can be lifted by means of a shackle. The top cover for transformers of rating 63 KVA and above shall also been provided with a lifting handle for lifting the tank top cover.
- 8.8. The tank shall be designed in such a way that the metallic part inside the H.V bushing shall remain immersed in oil when the oil level is at minimum oil level marking of oil level gauge for DTR 63 KVA and above and the HV busing pocket of the shall remain immersed in oil for transformers at minimum oil level marking for DTR upto and including 25 KVA. **Tank cover should have 90° downward bent edges on all sides to protect the gasket under the top cover from direct exposure to weather. The tank cover should have slightly slanted towards HV side so that rain water could not accumulate on the tank cover.** The rating , Sl. No. , P.O No. , year & month of manufacture, guaranteed for five years , property of TSECL, ., Energy efficiency level of Level2 type, marking with standard mark as per clause no. IS 1180 (Part1) of 2014 along with BIS marking shall be engraved / Embossed distinctly on the tank body in addition to those provided in the name & rating plate. Adequate care shall be taken so that tank does not get damaged during such engraving. Alternatively a M.S Sheet of adequate thickness containing those data being engraved in the sheet may be welded at a suitable location of the tank body. Adequate care must be taken so that the main tank/Hot resistant paint inside the tank/Transformer oil do





not suffer any damage during the process of welding. Nuts & Bolts and washers are to be provided for outside use on tank cover & accessories shall be as follows:

- a) Size 12 mm or below – Stainless Steel
- b) Above 12 mm. – Steel with suitable finish like Electro galvanized with passivation or hot dip galvanized.
- c) The bolts connecting the top cover of the transformer with the tank at the two opposite comers are to be provided with holes at their lower portions which would go beyond nuts so that the transformers may be sealed by inserting sealing wire in these holes.

8.9. **Inside** wall of the tank and the M.S. Channel shall be painted with varnish or with hot oil resistance paint. Stiffener shall be continuously welded on the tank wall.

8.10. All the welding of the tank & accessories must be double welded and all welding operations must be done by qualified welders.

8.11. Nuts, bolts, flat washers, spring washers as specified shall be used and suitable space to press the tank cover. Following minimum clearance between top yoke and top cover are to be maintained.

a) 25 KVA TRANSFORMER Oil level from top cover shall not be less than 25 mm and height of oil level top yoke or top of core shall not be less than 50 mm (at cold condition).

b) 63, 100 & 200 KVA (WITHOUT TAP CHANGER) Transformer (the clearance between top yoke or top of core and tank cover) shall not be less than 125 mm.

8.12. Silica gel breathers are to be provided on transformers of all ratings. A suitable metallic cover **should** be provided on the pipe on which the breather is provided at a location just above the breather so that it can protect rain water from falling directly onto the breather. Conservators are to be provided of ratings 63, 100 and 200 KVA. The pipe for connecting the breather should be provided with a metallic plate suitable shaped in the form of a canopy and at a point of the pipe beneath which the breather so that the rain water does not fall onto the breather directly. The moisture absorption shall be indicated by a change in the colour of silica gel crystals which should be visible from a distance. The volume of the breather shall be suitable for 500gm. Of silica gel conforming to IS:3401 for transformers upto 160 KVA. The conservator shall be liberally dimension-ed such that with the lowest ambient temperature and no load on the transformer. The oil level shall not recede too low with the highest ambient temperature & permissible overload on the transformer, the oil will not spill into the breather pipe or to the exterior to waste. The conservator shall be provided with oil level indicator of prismatic type with minimum, normal & maximum temperature markings. The inside diameter of the pipe connecting the conservator to the main tank shall be within 25 to 50 mm and it should be projected into the conservator in such a way that its end is approximately 20 mm above the bottom of the conservator. Conservators shall not be provided for 25 KVA DTR. For DTR 63, 100 & 200 KVA conservators of suitable dimension shall have to be provided. The conservator shall not have any Drain Plug for transformer of 63, 100 & 200 KVA ratings. Filling hole with threaded air tight metallic cover shall be provided as usual. Conservator pipe for 63, 100 & 160 KVA transformers shall be welded on the tap cover. Conservators along with silicagel breathers are to be provided in the transformers. The conservator shall be liberally dimensioned such that with the lowest ambient temperature and no load on the transformer, the oil level shall not recede too low and with the highest ambient temperature and permissible over load on the transformer the oil will not spill into the breather pipe or to the exterior to waste. The conservator pipe hole fitted to the tank cover shall be provided with a suitable slanted plate, if required so that while pouring oil into the transformer through conservator, oil does not fall directly on the winding. Care should be taken so that oil flow is not impeded. Explosion



vents for 100 & 200 KVA transformers shall also be welded on the Cover. Air release plug should be provided on the top of the explosion vent, and in tank cover to release any entrapped air. Thermometer pocket as per relevant ISS should be provided on top cover for measurement of top oil temperature. The thermometer pocket should be welded on tank top cover having threads on projected portion of top cover so that the pocket can be covered by a metallic cap having thread inside.

- 8.13. **Rollers:-** For Transformers of rating 200 KVA, 4 Nos. rollers of 150 mm diameter and 50 mm width shall be provided.
- 8.14. **Tank Base Channel:** To be fitted across the length of the transformer.
- i. For 16 KVA Transformer - Two channels of 75 mm x 40 mm.
  - ii. For 25 KVA Transformer - Two channels of 75 mm x 40 mm.
  - iii. For 63 KVA Transformer - Two channels of 75 mm x 40 mm.
  - iv. For 100 KVA Transformer - Two channels of 75 mm x 40 mm.
  - v. For 200 KVA Transformer - Two channels of 100 mm x 50 mm.

- 8.15. **LIGHTNING ARRESTOR:- 9 KV, 5 KA** Metal oxide lightning arrestor, Distribution class type of Make-CGL / Oblum / Rechem / Lamco conforming to relevant standard( IS:- 3070 Part-III) , one number per phase shall be provided and to be fitted under the H.V Bushing for **Transformers of rating 100, 200**, The L.A should be clamped to HV side bushing with galvanized nut & bolts and the strip should be accommodated in such a manner that the riser from the ground can be connected properly. All necessary arrangement accompanied with HT connector & Flipper etc. shall have to be made for in- built protection of transformer from Lightning / high surge. **1(one) Set (i.e 3 nos) of L.A with each transformer should also be provided / supplied as extra for future maintenance with out any fitting fixing with Transformer.**

**N.B:- Type Test Certificate of L.A (not older than 3 years as on the date of inspection of material must be submitted at the time of Pre-Despatch Inspection of Transformer**

## 9.0 CONSERVATOR FOR NON-SEALED TYPE TRANSFORMER

- 9.1. Transformers of ratings 63 KVA and above with plain tank construction, the provision of conservator is mandatory. For corrugated tank and sealed type transformers with or without inert gas cushion conservator is not required .
- 9.2. When a conservator is provided, oil gauge and the plan or dehydrating breathing device shall be fixed to the conservator which shall also be provided with a drain plug and a filling hole (1 1/4" normal size thread) with cover. The capacity of a conservator tank shall be designed keeping in view the total quantity of oil and its contraction and expansion due to temperature variations. In addition, the cover of main tank shall be provided with an air release plug to enable air trapped within to be released, unless the conservator is so located as to eliminate the possibility of air being trapped within the main tank.
- 9.3. The inside diameter of the pipe connecting the conservator to the main tank should be 25 to 50 mm and it should be projected into the conservator so that its end is at least 20 mm above the bottom of the conservator so as to create a sump for collection of impurities. The minimum oil level corresponding to 5° C should be above the sump level.
- 9.4. **Breather:** Breather joints will be screwed type. It shall have die-cast Aluminium body. Inside container for silicagel will be of tin sheet. Make of breathers shall be subject to purchaser's approval. Volume of breather shall be suitable for **500 gm (Minimum)** of Silicagel.



### 10.0 COOLING ARRANGEMENT:

- 10.1 The transformer shall be suitable for loading of 100% continuous maximum rating with 'ONAN' cooling without exceeding the thermal limit at all tap positions.
- 10.2 The DTR 25 KVA and above may be fitted with round or elliptical cooling tubes bent and welded to tank or radiators. Consisting of a series of separate circular or elliptical tubes, or a pressed steel plate assembly formed into elliptical or other oil channels, welded at their top and bottom to the tank.
- 10.3 The round cooling tubes shall be made of mild steel (ERW) having a minimum wall thickness of 1.50 mm and a clean bright internal surface free from rust and scale. They shall be suitably branched to protect them from mechanical shocks normally met in transportation and damp the modes of vibration transmitted by the active part of the transformer in service. The elliptical tubes or elliptical oil channels of pressed steel plate at least of 18 SWG (or 1.25mm thickness).
- 10.4 The radiator header on the upper side should be placed beneath the LV bushing pocket so that due to oil leakage from the gaskets of LV bushing oil level does not in any way go below the upper side of top radiator header and in the process effectiveness of the radiators for cooling is not lost.
- 10.5 The manufacture will have to provide information regarding wall surface area of tank radiator cooling tubes separately as part of the guaranteed technical particulars.
- 10.6 Heat dissipation by tank walls excluding top and bottom- Tenderer should submit the calculation sheet.
- 10.7 Heat Dissipation by fin type radiator will be worked out on the basis of manufacturers' data sheet. **Tenderer should submit the calculation sheet.**
- 10.8 Radiators shall be provided on both sides. They should be fixed at right angle to the sides and not diagonally.

### 11.0 Bushings: -

- i) All bushings shall conform to the requirements of latest revision of IS:3347 and other relevant standards. Bushings must be well processed, homogeneous and free from cavities and other flaws. Glazing must be uniform in colour and free from blisters, burns and other defects. The bushing rods & nuts shall be made of brass material 12 mm diameter for both HT and LT bushings. The bushings shall be fixed to the transformer on side with straight pockets and in the same plain or on the top cover top cover for transformers above 100 KVA. For transformers of 100 KVA and below the bushing can be mounted on pipes. The tests as per IS 2099 and IS 7321 shall be conducted on the bushings. The Bushings can be of porcelain/epoxy material. For 11KV, 17.5 KV class bushing and for 0.433/0.433 KV, 1.1 KV class bushing shall be used. Dimensions of bushings of the voltage class shall conform to the standards specified. Arcing horns shall be provided on HV bushings. The Lightning Impulse voltage of H.V bushing shall be 95 KVP and short duration Power frequency voltage shall be 28 KV (RMS). The LV bushing shall have short duration Power frequency voltage shall be 3 KV (RMS). The Bushings shall be of reputed make. The Bushing manufacturer shall have credential of supply of Bushings and have testing facility for bushing. The minimum phase to phase and phase to earth clearance in air in case of outdoor type bushing shall be as follows:

ii)

Voltage	Clearance	
	Phase to Phase	Phase to Earth
33 KV	350 mm	320 mm
11 KV	255 mm	140 mm
LV	75 mm for DTR upto 25 KVA and 85 mm beyond 25 KVA	40 mm

- iii) For 11 KV- 12 KV Bushing will be used and for 433 volts 1.1 KV terminal bushing will be used. Bushings of the same voltage class shall be interchangeable. Bushings with plain sheds as



per IS - 3347 shall be mounted on side of the tank and not on the top cover. Only continuous sheet metal pocket shall be provided for mounting of all H.V/L.V. bushings and the same shall not be fixed on pipes. Sheet metal pocket shall be designed in such a way that all HT bushings shall remain parallel and equidistant all through and inside connections of winding to bushings shall remain within the pocket. Bushings having been type tested as per IS-3347 shall only be acceptable.

- iv) Internal Connections: - In case of HV winding, all jumpers from winding's to bushing shall have cross section larger than the winding conductor (normally, 1.5 times). For copper winding, joints will be made by using silver brazing alloy. alternatively joints will be made by using tubular connectors properly crimped at three spots.
- v) LT star connection will be made by using Copper Flat and properly brazed or bolted with crimped lugs on winding by means of plain or spring washers and lock nuts to the flat. Other end of the conductor is brazed on "L" shape copper flat and flat nut bolted with neutral bushing Stud. The star connection should be wrapped with cotton/paper tape. Firm connection for LV winding to bushings shall be made by adequate size of "L" shape flat, nut bolted with LV Bushing stud. SRBP tube / insulation paper should be used for delta connection and on the portion of HV winding joining to HV bushing.

## 12.0 PAINTINGS : - SURFACE PREPERATION & PAINTING:

12.1 GENERAL:- All paints, when applied in a normal full coat, shall be free from runs, sags, wrinkles, patchiness, brass marks or other defects.

- i) All primers shall be well marked into the surface, particularly in areas where painting is evident and the first priming coat shall be applied as soon as possible after cleaning. The paint shall be applied by airless spray according to manufacturer's recommendation. However, wherever airless spray is not possible, conventional spray be used.
- ii) After all machining, forming and welding has been completed, all steel work surfaces shall be thoroughly cleaned of rust, scale, welding slag, or spatter and other contamination prior to any painting.
- iii) Steel surfaces shall be prepared by shot blast cleaning (IS 9954).
- iv) Chipping, scraping, and steel wire brushing using manual or power driven tools can not remove firmly adherent mill-scales. This methods shall only be used where blast cleaning is impractical.

### 12.2 Protective coating:

- i) As soon as all items have been cleaned and within four hours of subsequent drying, they shall be given suitable anti corrosion protection.
- ii) Following are the types of paint which may be suitably used for the items to be to be painted at shop and supply of matching paint to site.
  - a) Hot oil resistant(Proof) or varnish paint for inner surface .
  - b) For external surfaces one coat of thermos setting powder paint or one coat of epoxy primer followed by two coats of polyurethane base paint. These paints can be either air drying or stoving.

### 12.3 Painting Procedure:

- a) All prepared steel surfaces should be painted before visible re-rusting occurs or within 4 hours, whichever is sooner. Chemical treated steel surfaces shall be primed as soon as the surface is dry and while the surface is still warm.
- b) Where the quality of film is impaired by excess film thickness(Wrinkle, mud cracking or general softness) the supplier shall remove the unsatisfactory paint coating and apply another coating. As a general rule, the dry film thickness should not exceed the specified minimum dry film thickness by more than 25%.

12.4 Damaged paintwork: - Any damage occurring to any part of a painting scheme shall be made good to the same standard of corrosion protection and appearance as that was originally applied.

### 12.5 Dry Film thickness:

- a) To the maximum extent practicable the coats shall be applied as a continuous film of uniform Thickness and free from pours. Overspray, skips, runs, sags, and drips should be avoided. The different coats may or may not be of same colour.



- b) Each coat of paint shall be allowed to harden before the next is applied as per manufacturer's recommendation.
- c) Particular attention must be paid to full film thickness at the edges.
- d) The requirement for dry film thickness (DFT) of paint and the materials to be used shall be as given below:

Sl No	Paint Type	Area to be painted	No of coats	Total minimum dry film thickness, (in Microns)	
1.	Thermosetting Power Paint.	Inside	01	30	
		Outside	01	60	
2.	Liquid Paint	a. Epoxy (Primer)	Outside	01	30
		b. Polyurethane (finish coat	Outside	02	25 each
		c. Hot oil resistant paint / Varnish	Inside	01	35 / 10

#### 12.6 Test for painted surface:

- a) The painted surface shall be tested for paint thickness.
- b) The painted surface shall pass the cross hatch adhesion test and impact test as acceptance test and salt spray test and hardness test as type test as per ASTM standard.
- c) **The paint work shall also come under the coverage of guarantee period of the equipment.**
- d) **Before** painting or filling with oil, all nu-galvanized parts shall be completely cleaned & free from rust, scale & grease and all external surface on castings shall be filled by metal deposition.
- e) **The** interior of all transformer tank & Internal structural steel work shall be thoroughly cleaned of all scale & rust by sand blasting or other approved method. This surface shall be painted with hot oil resisting varnish or paint.

**13.0 EARTHING TERMINALS :** Two earthing terminals with lugs capable of carrying the full amount of lower voltage , short circuit current of transformer continuously for a period of 5 Sec. shall be provided on tank body at suitable locations.

#### 14.0 RATING & DIAGRAM PLATE:-

- a) A rating plate bearing the data specified in the relevant clauses of IS 1180 (Part 1) of 2014 including connection diagram, Vector group, Voltage LV & HV, LV & HV current, percentage Impedance, Loss figure, Makers name, serial no etc. are to be provided along with the transformer. BIS logo for BIS level 2 CRGO core Aluminium winding is to be marked.
- b) The total weight of finished transformer along with the un-tanking weight of core & winding is to be mentioned.
- c) Guaranteed maximum temp rise in oil & winding should be mentioned. 12.04 It should be mentioned that the loss figures of the DTR corresponds to Efficiency Leve2 of IS 1180 (Part !) of 2014.
- d) The Guaranteed values of Temperature rise of top oil & winding are to be mentioned.
- e) "Property of TSECL" is also to be mentioned .
- f) The transformer shall also be marked with standard mark as per clause no. 13.4 of IS 1180 (Part 1) of 2014.

**15.0 MOUNTING ARRANGEMENT:** The Mounting arrangement shall be as per clause no. 14 of IS 1180 (Part 1) of IS2014 or latest amendment thereof. The 200 KVA ;11/0.433 KV transformer may also be placed on concrete base. However the distance between the hole centres shall be 415 mm. without any tolerance.

#### 16.0 DUTY UNDER FAULT CONDITION :

- a) It is to be assumed that abnormal voltage will be maintained on one side of the transformer when there is a short circuit between phases or to earth on the other side.





- b) The transformer may be directly connected to an underground or overhead line and may be switched into and out of service together with or without its associated incoming / outgoing line.
- c) The thermal ability to withstand short circuit shall be three seconds without injury for 3 phase dead short circuit at the terminals. The related calculation is to be submitted.
- d) **Over Load Capacity:** Each transformer shall be capable of carrying sustained overload as stated is IS 6600.

**17.0 FITTINGS:-** The following fittings shall be provided with the Transformers.

- i) Name , rating & terminal marking plates
- ii) Two nos. earthing terminals with the earthing symbol  $\perp$  with lugs
- iii) Lifting Lugs for the complete transformer as well as for core & winding assembly (2nos each)
- iv) Pole / plinth mounting arrangement.
- v) Dehydrating breather (Silica gel type) which would not permit ingress of rain water and insects.
- vi) H.V. Bushing with arcing horn.
- vii) L.V. Bushing for phases & neutrals.
- viii) One no. oil filling hole with cover on the tank top cover located right above the centre of top yoke for 25 KVA DTR.
- ix) One no. oil level gauge of prismatic type with Min , Normal & Max Temperature Markings at suitable location of tank for 25 KVA and for 63, 100 & 200 KVA DTR the same shall be fitted in the conservator.
- x) Conservator (for 63, 100 & 200 KVA DTR)
- xi) Drain Valve ( for 25 , 63 , 100 & 200 KVA DTR) [ REC type with 3/4" plug ]
- xii) Filter Valve ( for 63 , 100 & 200 KVA DTR) [ Wheel valve -- 3/4" size ]
- xiii) Explosion Vent with Air release plug( for 100 & 200 KVA DTR )
- xiv) Air release plug on the tank top cover for 63 , 100 & 200 KVA DTR and thermometer pocket as per specification on tank top cover located right above the centre of top yoke.
- xv) The thermometer pocket shall have threaded metallic cover.

**18.0 Lifting and Haulage facilities :** -Each transformer tank shall be provided with lifting lugs suitable for lifting of transformer complete with oil Suitable holes shall be provided in the base channel of the transformer tank for fixing in the D. P. Structure above ground level of height 4.5 meter approx.

**19.0 Insulating Oil : TRANSFORMER OIL:**

- A. The oil shall be as specified in IS:335-1993 or it's latest amendment and it shall free from moisture and have uniform quality throughout., with following technical particulars.
- B. Use of recycled oil is not acceptable.
- C. Oil shall be filtered and tested for breakdown voltage (BDV) and moisture content before filling.
- D. The oil shall be filled under vacuum.
- E. The design of the materials and processes used in the manufacture of transformer, shall be such as to reduce to a minimum the risk of development of acidity in the oil.
- F. The transformer oil is to be procured from reputed manufacturer only. During inspection of transformer the manufacturer may have to submit the complete test report as collected from the oil – manufacturer, whenever asked, failing which the transformer may not be accepted.

**ANNEXURE-A**

**TECHNICAL PARTICULARS OF TRANSFORMER OIL**

Sl. No	Characteristics	Requirements
<b>A</b>	<b>NEW OIL</b>	
1	<b>Flash Point Pensky Marten (Closed)</b>	140U
2	<b>Neutralization value</b> a) Total acidity, Max b) Inorganic acidity	a) 0.03 mg KQH/g b) NIL
3	Corrosive Sulfur	Non-corrosive
4	<b>Electric Strength (breakdown voltage Min)</b>	





	a) New Unfiltered Oil b) New oil after filtration	30 KV (rms) 60 KV (rms)
5	Dielectric dissipation factor (tan delta) at 90° c	0.002
6	<b>Specific resistance (resistivity)</b> a) at 90°C Min. b) at 27°C Min	35x10 <sup>12</sup> Ohm-cm 1500x10 <sup>12</sup> Ohm-cm
7	<b>Oxidation stability</b> a) Neutralization value after oxidation, Max b) Total sludge after oxidation Max c) S.K. Value	0.40 mg KQH/g 0.10% by weight 4% to 8%
8	<b>AGEING CHARACTERISTICS</b> Ageing characteristics after accelerated ageing(open breaker method with copper catalyst) <b>a) Specific resistance (resistivity)</b> i) at 27°C ii) at 90°C <b>b) Dielectric dissipation factor(Tan Delta)</b> <b>c) Total acidity in mg KgH/g</b> <b>d) Total sludge value</b>	2.5x10 <sup>12</sup> Ohm-em(Min) 0.2x10 <sup>12</sup> Oh-cm(Min) 0.20 Max 0.05 Max 0.05%by weight(Max)
<b>B</b>	<b>CHARACTERISTICS OF OIL IN THE TRANSFORMER</b> The important characteristics of the transformer oil after it is filled in the transformer (within 3 months of filling) shall be as follows :-	
1	Electric strength (breakdown voltage)	40 KV(Min.)
2	Dielectric dissipation factor Tan. Delta at 90°C	0.01 (Max.)
3	Specific resistance (Resistivity)at 27°C(Ohm-cm)	10 x10 <sup>12</sup> Ohm-cm
4	Flash point ,PM.(closed)	140° C (Min)
5	Interfacial tension at 27°C	0.03 N/m (Min.)
6	Neutralization value (total acidity)	0.05mgQH/g(Max.)
7	Water content	35 PPM (Max.)

**20.0 Internal Earthing Arrangement:-** 18.01 All metal parts of the transformer with the exception of the individual core lamination , core bolts and associated clamping plates shall be maintained at same fixed potential & core should be earthed at two points.

**21.0 ROUTINE & TYPE TEST AND OTHER COMMON DETAILS FOR 16, 25, 63, 100 & 200 KVA DISTRIBUTION TRANSFORMER :-**

**A. Testing & Inspection : -**

**Routine Test :** Offered transformers to the extent of minimum of 10% of the offered quantity subject to a minimum quantity of 1 no. for rating up to 100KVA; 11/0.433 KV and for rating 200KVA; 11/0.433 KV, 100% of the offered transformer shall be subjected to routine tests at the manufactures works. One transformer for each lot of offered item will be subjected to Temperature rise test at minimum tap position. The following tests are to be carried out :-

- a) Measurement of winding resistance.
- b) Ratio, polarity and phase relationship c) % Impedance voltage at 75°C and at 50 Hz.
- d) Load losses at 50% & at 100% loading at 75°C e) No load loss at 50 Hz and no load current at rated voltage.
- f) Insulation resistance.
- g) Induced over voltage withstand.
- h) Separate source voltage withstand
- i) Characteristic requirement of oil sample will be as per IS: 1866 -1983 amended upto 1987.



- j) Magnetizing current at rated voltage & frequency & 112.5 % of rated voltage & frequency should not exceed the limit as per IS: 1180 ( Part – I ) 1989 C 1 . 22.6 .
- k) Temperature Rise Test as per relevant clause of IS 1180(Part-1) of 2014 will be conducted on one transformer of each offered lot for each rating of DTR.
- l) Pressure Test: As per Clause no. 21.5 of IS 1180 (Part-1) 2014 m) Oil leakage Test: As per Clause no. 21.5 of IS 1180 (Part-1) 2014 19.02

- B. Pressure Test(type test):-**The transformer with all fittings including bushings and shall be subject to air pressure of 80Kpa above atmosphere for 30 minutes and vacuum of 250 mm. Of mercury upto 200KVA & 500 mm. of mercury for rating above 200KVA for 30 minutes. The permanent deflection of flat plate after pressure has been released shall no exceed values given below:- Length Of Plate Deflection for rating upto 200KVA Upto 750m 5 mm 751 to 1250 mm 6.5 mm If required, the manufacturers should submit pressure test certificates for the transformer tanks at least for one Tank for each batch either conducted by their fabricators or by themselves. Transformer tanks should be double welded electrically as per the specification.
- C. Routine Test:** The transformer tank with welded/bolted cover shall be tested at a pressure of 35 KPa above atmosphere pressure maintained inside the tank for 10 mins. There should be no leakage in any part.

**22.0 Oil Leakage Test:** The assembled transformer with all fittings including the bushing in position shall be tested at a pressure equivalent to twice the normal head measured at the base of the tank for 8 hr. There should be no leakage at any point. The manufacturers should submit pressure test certificates for the transformer tanks at least for one batch either conducted by them or by their fabricators, for which order is placed with them and edges(both inside and outside) of the transformer tanks should be double welded electrically and scrupulously as per the specification.

- A. Type test :-** In addition to the routine tests, the following type & special tests, are to be carried out at CPRI/ NABL Accredited third party Laboratory or any other Govt. recognized Test House on one transformer of the particular rating after being eligible and placement of Purchase Order of the particular rating .
- a) Dynamic short circuit withstand test to be conducted as per IS 2026(Part 5)
  - b) Lightning Impulse voltage withstand test to be conducted as per IS 2026(Part 3) The Impulse voltage wave shape should be Chopped on tail..The manufacturer will have to submit thermal calculation of short circuit withstand ability for 2 seconds and 3 seconds.
  - c)The purchaser intends to procure transformers designed and successfully tested for short circuit and impulse test. In case the transformers proposed for supply against the order are not exactly as per the tested design, the suppliers shall be required to carry out the short circuit test and impulse voltage test at their own cost in the presence of the representative of the Purchaser. The acceptance of supply is dependent on successful withstand of short circuit and healthiness of the active parts thereafter on un-tanking after a short circuit test. Apart from dynamic ability test, the transformers shall also be required to withstand thermal ability test or thermal withstand ability will have to be established by way of calculations.

**It may also be noted that the Purchaser reserves the right to conduct short circuit test and impulse voltage test in accordance with the ISS, afresh on each ordered rating at Purchaser's cost, even if the transformers of the same rating and similar design are already tested.** This test shall be carried out on a transformer to be selected by the purchaser either at their works when they are offered in a lot for supply or random sample units from the supplies already made. The findings and conclusions of these tests shall be binding on the supplier. In case the transformer does not pass in either of the tests and if the active part details are not found to be in line with the design tested and approved, the following punitive measures shall be taken:

- (i) 10% payment of the bill for the supplies already made will be recovered by the Purchaser.



(ii) For transformers already supplied, the guarantee period shall stand twice the normal guarantee period incorporated in the order and the period of performance Security Deposit shall be suitably extended to cover the extended guarantee period.

(iii) Further supply of balance quantity of transformers will not be accepted till another transformer from the manufactured batch is satisfactorily tested (or transformers are modified according to the testes design) for both tests at Supplier's cost and consequent to this if there is any delay in executing the order, the same shall be to Supplier's account.

The Purchaser reserves the right to take action as per terms and conditions of the order.

(iv) The test charges shall be borne by the firm.

**Note :** Purchaser reserves the right to get all or any type test carried out on at least one sample for each rating of transformer at the cost of supplier from any recognized laboratory government test house approved by the purchaser.

### **23.0 Performance under external short Circuit condition and limit of temperature rise-**

23.1 Heat run test shall have to be conducted at supplier's cost on one transformer of each rating in any offered lot during the course of supplies. In case of transformers with tapes shall be conducted on the lowest tap feeding corresponding losses at 75 degrees. To facilitate conduction of heat run test on any unit in any lot at any point of time during the supplies, the manufacturers will provide a thermometer pocket which gets immersed in oil on the side of the transformer in all the transformers. This pocket shall also be used for connecting thermal sensing device to monitor the variations in temperature and whenever required to operate the protective devices. The Sensor pocket shall be of 12 mm. diameter with blanking screwed cap, removable at site. The depth of the projecting stem of this pocket inside the transformer will be below oil level. It shall not infringe with electrical clearance nor obstruct the un tanking of the active part.

23.2 All transformers shall be capable of withstanding , without damaging the thermal and mechanical effects of short circuit at the terminal of any winding for 2 secs. The temperature in the winding after 2 secs of over current must not exceed 200oC for Al and 250oC for cu winding's.

23.3 **V a r i a t i o n % r e a c t a n c e :** The transformer so tested shall not exhibit more than 2 percent variation in percentage reactance for stack core after the short circuit test from the original measured value before testing according to clause 16.11.5.4 of IS:2026(Part-I),1977

**24.0 ACCEPTANCE TEST:-** The following tests shall be witnessed by the Purchaser's Representative at the works of manufacturer wherein the transformers should be offered along with factory routine test certificate as per relevant ISS and technical specification of the NIT.

(i) All the routine tests as mentioned in clause 12.1 shall be performed on minimum 10% quantity of offered lot.

(ii) Heat run test - One unit of the ordered quantity.

(iii) Verification of active parts on one unit of each rating of ordered quantity along with total weight of one unit.

One unit of each rating offered shall be dismantled at the time of pre-despatch inspection for physical verification for constructional details.

(iv) Further, the Purchaser's Inspector reserves the right to get the Spill Current Measurement Test and also the Pressure Test performed on any tank during his inspection.



**25.0 Type Test & special test Report as pre-requisites:** - The certified copies of valid type & special test reports for ISI clauses as per Energy Efficiency Level-2 specified in IS: 1180(Part-I):2014, Aluminium wound CRGO type 16, 25, 63, 100 & 160 KVA rating distribution transformer for which the bidder is participating from the Govt standard test Laboratories/Govt. approved laboratories/NAB accreditation third party laboratory shall be submitted along with the tender. The bidder should submit Type **Test Report** of Short circuit Test and Lightning Impulse voltage test **report etc. for the rating they are offering** along with drawing conducted from **CPRI, NABL accredited laboratory of third party /Govt. approved laboratories** carried out **within Five years** along with their offer having similar rating and type as that of the tendered item as **credential mentioned in ITB**, failing which their offer may not be technically accepted. The type test certificates for all ratings shall not be more than 5 years old from the date opening of the tender.

**26.0 TESTING FACILITIES :-** The tenderer should have adequate testing facilities with following instruments for all routine and acceptance tests and also arrangement for measurement of losses, resistance etc.

- I. **KV Meter ( 0 - 30 KV ) for 11 KV system .**
- II. **Volt Meter ( 0 - 1000 V ) .**
- III. **Milli ammeter for leakage current ( 0 - 100 ma ) .**
- IV. **Power Analyzer of reputed make ( should display 3 – phase current , voltage , watt and  $\Sigma$  3 –  $\emptyset$  Power )**
- V. **Megger - 2 . 5 KV.**
- VI. **Thermometer ( preferably Digital ) 0 - 1000 C**
- VII. **TTR Meter viii) Winding Resistance measurement ( Preferably ELTEL or reputed make )**
- VIII. **Digital Multimeter measure magnetizing current & core balance of 11 KV system x) Clamp on ammeter ( 0 - 300 A )**
- IX. **Instrument for measuring the thickness of different layers of painting.**
- X. **Instrument/Equipments required for testing of painting as per IS 1180 (Part 1) of 2014**
- XI. **Equipment for pressure test as per Clause no. 21.5 of IS 1180 (Part-1) 2014**
- XII. **Equipment for Oil leakage test as per Clause no. 21.5 of IS 1180 (Part-1) 2014 xv) 4(Four) nos. ambient pots as per relevant ISS for measurement of ambient temperature during Temperature rise Test.**
- XIII. **Instrument for measurement of Dry paint thickness.**

**27.0 ALL THE ABOVE TESTING EQUIPMENTS SHALL BE AVAILABLE IN THE TESTING LAB AND SHOULD BE CALIBRATED FROM NABL ACCRIDATED LABORATORY. COPY OF CALIBRATED CERTIFICATES AS PER GCC CLAUSE NO. 8 SHALL BE AVAILABLE WITH THE BIDDER AS AND WHEN REQUIRED.**  
**Note : To facilitate testing , arrangement should be made for carrying out Heat run test of two Transformers simultaneously.**

**28.0 Drawings & Manuals :-** The following drawings and manuals shall be furnished in triplicate along with tender

- i) General Arrangement outline drawing with plan , elevation and end view showing various dimension of transformer and its vital equipment including height of the bottom most portion of bushing from the bottom of base channel and also indicating thereon physical centre line & position of centre of gravity.
- ii) Cross sectional drawing showing various parts, including Core - coil assembly.
- iii) Drawing for rating & diagram plate, complete list of fittings, Net weight of core, winding, tank, oil, total weight, fixing arrangement of transformer in structures.



iv) Cross sectional details with Plan, Elevation, End view showing all internal clearance.

**29.0 Guaranteed Technical Particulars:-** Tenders shall be furnished with guaranteed technical particulars of equipment offered as per Schedule . Performance guarantee shall be based on guaranteed technical particulars.

**SCHEDULE OF GUARANTEED TECHNICAL PARTICULARS.**

**Annexure-B-**

(To be furnished and signed by the tenderer for each category of Transformer )

Sl. No.	PARTICULARS	GTP TO BE FILLED BY THE BIDDER FOR EACH OFFERED RATING
1	Name of the manufacturer & Factory address	::
2	Country of origin	::
2(a)	Whether the manufacturer has the BIS certification for manufacturing the item offered? If yes, Energy efficiency level for which BIS certification is Submitted?	:: ::
2(b)	Whether the manufacturer has uploaded Type, Special & other test reports required for BIS certification for manufacturing the item offered?	::
3	Applicable standard	::
4	Maximum continuous rating in KVA	::
5	No load voltage ratio (In KV/KV)	::
6	Rated frequency (in HZ)	::
7	Number of phases	::
8	Type of Cooling	::
9 Connections		
(i) H.V. Winding		
(ii) L.V. Winding		
10		Vector Symbol
11	(i) Temperature also under normal operating condition above ambient temperature	::
(a) Top oil (in 0 C.)		
(b) Winding (in 0 C)		
(ii) Maximum hot spot temperature of winding (in 0 C)		
12	Magnetizing current referred to H.V. at rated frequency	::
(a) At 90% rated voltage (in Amps)		
(b) At 100% rated voltage (in Amps)		
(c) At 112.5% rated voltage (in Amps)		
13	Power factor of magnetizing current at 100% rated voltage & frequency	::
14	No load current at rated voltage and rated frequency (in Amps)	::
15	Declared No load loss in watt at rated frequency & voltage (For the purpose of record)	::
16	Declared Load loss in Watt at 75 0C. at rated output and frequency (For the purpose of record)	::
17	Maxm Total Loss ( including NLL & FLL) at 50 % loading at 75 0C	::
18	Maxm Total Loss ( including NLL & FLL) at 100 % loading at 75 0C	::
19	Percentage Regulation at full load at 75 0C	::
(a) At unity power factor		



(b) At 0.8 power factor lagging		::
20	Efficiencies at 75 0 C (in percentage)	::
(a)	At full load	::
(i) At unity power factor		::
(b)	At ¾ full load	::
(i) At unity power factor		::
(ii) At 0.8 power factor lagging		::
(c)		At ½ full load
(i) At Unity power factor		
(ii) At 0.8 Power factor lagging		
2	Impedance voltage on rated KVA base at rated current and frequency at 75 0 C (in percentage)	::
2	(a) Resistance voltage at rated current and frequency at 75 0C (in percentage)	::
2	(b) Reactance voltage at rated current and frequency at 75 0C (in percentage)	::
2	Resistance at H.V. base at 75 0 C a) HV (between lines) (ohms) b) LV (between lines) (ohms)	::
2	Reactance at H.V. base at 50 c/s	::
2	Withstand time without injury for three phase dead short circuit at terminal (in seconds):	::
2	Short time current rating for short circuit with duration	::
6		
(a) H.V. Winding (in K Amps)		::
(b) L.V. Winding (in K Amps)		::
(c) Duration in seconds)		::
2	Permissible over loading with time at max amb temp a) 125% load after running with 50% load with steady temp rise. (hrs.)	::
7	b) 120% load after running with 100% load with steady temp rise. (hrs.)	
28	Core :	
(i)	Material Type :	
(ii)	Whether stack core / wound core type :	
(ii)	Flux density of Core and yoke : (a) At rated voltage at 50 HZ (in line/sq cm)	::
i)		
(b) At 112.5% rated voltage at 50 HZ (in line/sq cm)		
(iv)	Thickness of Stamping (in mm)	::
(v)	Type of Insulation between core lamination	::
(vi)	Approximate area of Cross Section of Core and yoke (in sq.mm)	::
(vii)	Material of Core clamping plate	::
)		
(vii)	Thickness of Core clamping plate (in mm)	::
i)		
(ix)	Insulation of Core clamping plate	::
(x)	Describe location/Method of Core grounding	::
(xi)	Please specify the use of primary core material in the offered transformer	
(xii)	Whether the proof of use of prime core material is enclosed.	
)		
29	Terminal Arrangement :	::
(i) high voltage		::
(ii) low Voltage		::





30	Positive Sequence Impedance between HV & LV winding on rated KVA base at rated current and frequency at 75 0 C. Winding temperature (in percent).	::
31	Zero Sequence Impedance at reference temperature of 75 0 C (in percent)	::
32	Details of windings :	::
	(i) Type of Winding : (ii) Joints in the windings soldering / brazing but in any case crimping is not allowed	::
	a) High Voltage ;	::
	b) Low Voltage	::
	(ii) Material of the winding conductor	::
	(a) High Voltage :	::
	(b) Low Voltage :	::
	(iii) Conductor Area	::
	(a) High voltage (in sq.mm)	::
	(b) Low Voltage (in sq.mm)	::
	(iv) Current density of winding at rated KVA	::
	(a) High Voltage (Amp per sq.cm)	::
	(b) Low voltage (Amps per Sq.cm)	::
	(v) Insulating material used for	::
	(a) High Voltage Winding	::
	(b) Low Voltage Winding	::
	(vi) Insulating material used between	::
	(a) High voltage and low voltage winding	::
	(b) Low Voltage winding and Core	::
33	Insulation withstand Test Voltages	::
	(i) Lightning Impulse withstand test voltage (KV Peak)	::
	(ii) Power frequency withstand test voltage (in KV rms for 1 mtn)	::
	(iii) Induced over voltage withstand test voltage (in KV rms)	::
34	Current in the winding at rated KVA	::
	(I) Low voltage (in Amps)	::
	(ii) High Voltage (in Amps)	::
35	Voltage per turn (KV per turn)	::
36	Ampere turn	::
37	Number of turns	::
	(i) Low Voltage	::
	(ii) High Voltage	::
38	Bushing	:: High Voltage                      Low Voltage
	(i) Make	::
	(ii) Type	::
	(iii) Applicable standard	::
	(iv) Insulation withstand test voltage	::
	(a) Lightning Impulse withstand test voltage (1.2 x 50 micro seconds (in KV Peak)	::
	(b) Power frequency withstand test voltage (in KV for 1 min )	::
	i) Dry	::



ii) Wet		::			
(v) Creepage distance in air		::			
(i) Total (in mm)		::			
(ii) Protected (in mm)		::			
(vi) Minimum height of the bushing					
39 Minimum clearance (in mm)		::			
Between live conductive parts and live conductive parts to earthed structure		In Oil		In Air	
		Between Phases	Phase to Ground	Between Phases	Phase to Ground
(i) H.V.					
(ii) L.V.					
4 0	Approximate weight of Transformer (in Kgs)	::			
(i) Core with clamping		::			
(ii) Coil with Insulation		::			
(iii) Core and winding		::			
(iv) Tank and fitting with accessories		::			
(v) Untanking weight		::			
(vi) Oil required for the transformer		::			
(vii) Total weight with Core, Winding, oil and fittings		::			
4 1	Details of Tank	::			
(i) Type of tank		::			
(ii) Approximate thickness of Sheet (in mm)		::			
(a) Sides		::			
(b) Bottom		::			
(c) Cover		::			
(iii) Vacuum withstand capacity		::			
(iv) Dimension of base channel (in mm x mm)		::			
42	Oil quality	::			
(i) Applicable standard		::			
(ii) Total quality of oil (in litres)		::			
43	Approximate overall Dimensions (in mm)	::			
(a) Length		::			
(b) Breadth		::			
(c) Height		::			
(d) Minimum height of bottom most portion bushing from bottom of base channel		::			
4 4	Minimum clearance height for lifting tank cover (in mm)	::			
4 5	Whether Type Test Report, Credential, Performance Certificate submitted as Pre-requisites as mentioned in respective clauses .	::			
4 6	Marking : whether agreeable to a) Punching of transformer Sl. No. on the Top yoke. b) Transformer Rating and Diagram plate along with Asset codification number shall be welded on the tr. Body.	::			
4 7	Whether they have facility for Air pressure test and oil leakage test in line with the technical specification	::			



48	Whether they have facility for painting and test in line with the technical specification	::
49	Whether they have facility for carrying out Tank Pressure & oil leakage test in line with the technical specification at their works	::
50	List of testing equipments available in the testing lab. of manufacturer in line with Cl. No. 31 . 00	::

Signature of the Representative of the firm with seal  
Name :  
Designation:

**30.0 MAXIMUM FLUX DENSITY AND CORE WEIGHT CALCULATION**  
(To be filled in by Bidder and shall be furnished with the Technical Bid)

Step No	Width of steps [mm]	Stack Thickness [mm]	Gross Iron Area [mm <sup>2</sup> ]
1			
2			
3			
4			
5			
6			
7			
8			
9			
10			
----			

$$B_{\max} = E / (4.44 \times f \times A_i \times N)$$

Where E = L.V. winding phase voltage / phase

f = Rated frequency = 50 HZ.

B<sub>max.</sub> = Maximum flux density in Tesla.

A<sub>i</sub> = Net iron area in sq.m = Gross iron area x stacking factor in sq.m

N = Number of L.V.winding, turns/phase

Stacking Factor = 0.97 maximum

**Core weight calculation:-**

Core dia [in mm] =

Window height [in mm] =                      Limb center [in mm] =

Weight of core = [3 x window height + 4 x limb centre + 2 x max. width] x Net iron area x Density of core

NB: - 1 Specific loss vs. flux density graph for the type of core lamination to be used has to be furnished.

2. VA/Kg. Vs flux density graph for the core lamination to be used has to be furnished.

3. Any other factor assumed for above calculation to be explained with reasons.

N.B.:- The bidder may use its own method of calculation towards determination of maximum flux density and weight of the core. But the same shall be supported with proper explanation and justification.



Place:

Date:

Signature of Tenderer with seal of Company



## D. TECHNICAL SPECIFICATION OF ALUMINIUM CONDUCTOR STEEL REINFORCED (ACSR) CONDUCTORS, "WEASEL", "RABBIT" and "DOG" ACSR

- SCOPE** :-This section covers design, manufacture, testing before dispatch, packing, supply and delivery to destination of Kms of "WEASEL", "RABBIT", "DOG", ACSR of sizes, 6/1/2.59mm, 6/1/3.35mm, & (6/4.72mm + 7/1.57mm) respectively.
- STANDARDS** :-The Conductor shall also comply in all respects with the IS: 398(Part-II)-1996 with latest amendments unless otherwise stipulated in this specification or any other International Standards which ensure equal or higher quality material.  
The ACSR Conductor shall also conform to the following standards.

Sl. No.	Indian Standards	Title	International
1	IS:209-1979	Specification for Zinc	BS-3436-1961
2	IS:398-1996	Specification for aluminium conductors for overhead transmission purposes.	
	Part-II	Aluminium conductors Galvanized steel reinforced	IEC-209-1966 BS-215(Part-II)
3	IS:1521-1972	Method of Tensile Testing of Steel wire	ISO/R89-1959
4	IS:1778-1980	Reels and Drums for Bare conductors	BS-1559-1949
5	IS:1841-1978	E.C. Grade Aluminium rod produced by rolling	
6	IS:2629-1966	Recommended practice for Hot Dip Galvanizing of iron and steel	
7	IS:2633-1986	Method of testing uniformity of coating of zinc coated articles.	
8	IS:4826-1968	Galvanized coatings on round steel wires.	ASTM A472-729
9	IS:5484-1978	E.C. Grade Aluminium rod produced by continuous casting and rolling.	
10	IS:6745-1972	Methods of determination of weight of zinc-coating of zinc coated iron and steel articles	BS-443-1969

Standards other than IS-398 shall be accompanied by the English version of relevant standards in support of the guaranteed technical particulars to be furnished as per format enclosed.

- GENERAL TECHNICAL REQUIREMENTS**:-The General Technical Requirements are given in Section-II. The Conductor shall conform to these technical requirements.  
The Bidder shall furnish Guaranteed Technical Particulars in Section-III.
  - MATERIALS/WORKMANSHIP**
    - The material offered shall be of best quality and workmanship. The steel cored aluminum conductor strands shall consist of hard drawn aluminum wire manufactured from not less than 99.5% pure electrolytic aluminum rods of E.C. grade and copper content not exceeding



0.04%. They shall have the same properties and characteristics as prescribed in IEC: 889-1987. The steel wire shall be made from material produced either by the acid or basic open hearth process or by electric furnace process or basic oxygen process. Steel wire drawn from Bessemer process shall not be used.

- 3.1.2. The steel wires shall be evenly and uniformly coated with electrolytic high grade, 99.95% purity zinc complying with the latest issue of IS-209 for zinc. The uniformity of zinc coating and the weight of coating shall be in accordance with Section-II and shall be tested and determined according to the latest IS-2633 or any other authoritative standard.
- 3.1.3. The steel strands shall be hot dip galvanized and shall have a minimum zinc coating of 250 gm/sq. m after stranding. The coating shall be smooth, continuous, and of uniform thickness, free from imperfections and shall withstand minimum three dips after stranding in standard piece test. The steel strands shall be preformed and post formed in order to prevent spreading of strands in the event of cutting of composite core wire. The properties and characteristics of finished strands and individual wires shall be as prescribed in IS:398-1996

4. **CONDUCTOR PARAMETERS:-**The Parameters of individual strands and composite steel core aluminium conductor, shall be in accordance with the values given in this Section.

Creep in a conductor is attributed partly due to settlement of strands and partly due to non-elastic elongation of metal when subjected to load. The manufacturer of conductor shall furnish the amount of creep which will take place in 10, 20, 30, 40 and 50 years along with the supporting calculations. The calculations should be based on everyday temperature of 32 °C and everyday tension of 25% of UTS of conductor of 11/33 KV Feeders.

5. **TOLERANCES: -** The following tolerances shall be permitted:

- (a) Tolerance on nominal diameter of aluminium wires:  $\pm 1$  (one) percent.
- (b) Tolerance on nominal diameter of galvanized steel wires:  $\pm 2$  (two) percent.

6. **SURFACE CONDITIONS :-**All aluminium and steel strands shall be smooth, and free from all imperfections, spills/and splits. The finished conductor shall be smooth, compact, uniform and free from all imperfections including spills and splits, die marks, scratches, abrasions, scuff marks, kinks (protrusion of wires), dents, pressmarks, cut marks, wire cross-over, over-riding looseness, pressure and/or unusual bangle noise on tapping, material inclusions, white rust, powder formation or black spots (on account of reaction with trapped rain water etc.), dirt, grit, etc. The surface of conductor shall be free from points, sharp edges, abrasions or other departures from smoothness or uniformity of surface contour that would increase radio interference and corona losses. When subjected to tension upto 50% of the ultimate strength of the conductor, the surface shall not depart from the cylindrical form nor any part of the component parts or strands move relative to each other in such a way as to get out of place and disturb the longitudinal smoothness of the conductor.

7. **JOINTS IN WIRES**





- 7.1. **Aluminum wires** :-During stranding, no aluminium wire welds shall be made for the purpose of achieving the required conductor length.  
No joint shall be permitted in the individual aluminium wires in the outer most layer of the finished Conductor. However, joints in the 12 wire & 18 wire inner layer of the conductor are permitted but these joints shall be made by the cold pressure butt welding and shall be such that no two such joints shall be within 15 meters of each other in the complete stranded conductor.
- 7.2. **Steel wires**:-There shall be no joints in finished steel wires forming the core of the steel reinforced aluminium conductor.
8. **STRANDING** :-The wires used in construction of the stranded conductor, shall, before stranding, satisfy all requirements of IS-398 (Part-II) 1996.  
In all constructions, the successive layers shall be stranded in opposite directions. The wires in each layer shall be evenly and closely stranded round the underlying wire or wires. The outer most layer of wires shall have a right hand lay. The lay ratio of the different layers shall be within the limits given under Section-II.
9. **PACKING**
- 9.1. The conductor shall be supplied in non-returnable strong wooden drums provided with lagging of adequate strength constructed to protect the conductor against any damage and displacement during transit, storage and subsequent handling and stringing operations in the field. The drums shall generally conform to IS-1778-1980 and latest version except as otherwise specified hereinafter. The conductor drums shall be adequate to wind one standard length of 2,500 meters of WEASEL/RABBIT/DOG, ACSR.
- 9.2. The drums shall be suitable for wheel mounting and for letting off the conductor under a minimum controlled tension of the order of 5KN. The conductor drums shall be provided with necessary clamping arrangements so as to be suitable for tension stringing of power conductor.
- 9.3. The bidders should submit their drawings of the conductor drums along with the bid. After placement of letter of intent the Manufacturer shall submit four copies of fully dimensioned drawing of the drum for Employer's approval. After getting approval from the Employer, Manufacturer shall submit 30 more copies of the approved drawings for further distribution and field use.
- 9.4. All wooden components shall be manufactured out of seasoned soft wood free from defects that may materially weaken the component parts of the drums. Preservative treatment for anti-termite/anti fungus shall be applied to the entire drum with preservatives of a quality which is not harmful to the conductor.
- 9.5. All flanges shall be 2-ply construction with 64 mm thickness. Each ply shall be nailed and clenched together at approximately 90 degrees. Nails shall be driven from the inside face of the flange, punched and then clenched on the outer face. Flange boards shall not be less than the nominal thickness by more than 2 mm. There shall not be less than 2 nails per board in each circle.
- 9.6. The wooden battens used for making the barrel of the conductor shall be of segmental type. These shall be nailed to the barrel supports with at least two nails. The battens shall be



- closely butted and shall provide a round barrel with smooth external surface. The edges of the battens shall be rounded or chamfered to avoid damage to the conductor.
- 9.7. Barrel studs shall be used for construction of drums. The flanges shall be holed and the barrel supports slotted to receive them. The barrel studs shall be threaded over a length on either end, sufficient to accommodate washers, spindle plates and nuts for fixing flanges at the required spacing.
- 9.8. Normally, the nuts on the studs shall stand protruded of the flanges. All the nails used on the inner surface of the flanges and the drum barrel shall be countersunk. The ends of the barrel shall generally be flushed with the top of the nuts.
- 9.9. The inner cheek of the flanges and drum barrel surface shall be painted with bitumen based paint.
- 9.10. Before reeling, card board or double corrugated or thick bituminized waterproof bamboo paper shall be secured to the drum barrel and inside of flanges of the drum by means of a suitable commercial adhesive material. The paper should be dried before use. Medium grade craft paper shall be used in between the layers of the conductor. After reeling the conductor the exposed surface of the outer layer of conductor shall be wrapped with thin polythene sheet across the flanges to preserve the conductor from dirt, grit and damage during transportation and handling and also to prevent ingress of rain water during storage/transport.
- 9.11. A minimum space of 75 mm shall be provided between the inner surface of the external protective lagging and outer layer of the conductor. Outside the protective lagging, there shall be minimum of two binders consisting of hoop iron/ galvanized steel wire. Each protective lagging shall have two recesses to accommodate the binders.
- 9.12. Each batten shall be securely nailed across grains as far as possible to the flange edges with at least 2 nails per end. The length of the nails shall not be less than twice the thickness of the battens. The nail shall not protrude above the general surface and shall not have exposed sharp edges or allow the battens to be released due to corrosion.
- 9.13. The conductor ends shall be properly sealed and secured with the help of U-nails on one side of the flanges.
- 9.14. Only one standard length of conductor shall be wound on each drum. The method of lagging to be employed shall be clearly stated in the tender.
- 9.15. As an alternative to wooden drum Bidder may also supply the conductors in non-returnable painted steel drums. The painting shall conform to IS: 9954-1981, reaffirmed in 1992. Wooden/ steel drum will be treated at par for evaluation purpose and accordingly the Bidder should quote the package.
- 10. LABELLING AND MARKING :-**The drum number shall be branded or gauged or stencilled into the flange. An arrow shall be marked on the sides of the drum, together with the words "Roll this way". Each drum shall have the following information provided on the outside of the flange stencilled with indelible ink.
- i) Manufacturer's name and address.
  - ii) Contract/Specification number.
  - iii) Size and type of conductor.
  - iv) Net weight of the conductor.



- v) Gross weight of the conductor and drum.
- vi) Length of the conductor.
- vii) Position of the conductor end.
- viii) Drum and lot number.
- ix) Name and address of the consignee.
- x) Month and year of manufacture.
- xi) The drum may also be marked with standard specification as per which the conductor is manufactured.

## 11. STANDARD LENGTHS

11.1. The standard length of the conductor shall be 2,500 metres to 7,000 meters. Bidder shall indicate the standard length of the conductor to be offered by them. A tolerance of plus or minus 5% on the standard length offered by the bidder shall be permitted. All lengths outside this limit of tolerance shall be treated as random lengths.

11.2. Random lengths will be accepted provided no length is less than 70% of the standard length and total quantity of such random length shall not be more than 10% of the total quantity order. When one number random length has been manufactured at any time, five (5) more individual lengths, each equivalent to the above random length with a tolerance of +/-5% shall also be manufactured and all above six random lengths shall be dispatched in the same shipment. At any point, the cumulative quantity supplied including such random lengths shall not be more than 12.5% of the total cumulative quantity supplied including such random lengths. However, the last 20% of the quantity ordered shall be supplied only in standard length as specified.

11.3. Bidder shall also indicate the maximum single length, above the standard length, he can manufacture in the guaranteed technical particulars of offer. This is required for special stretches like river crossing etc. The Employer reserves the right to place orders for the above lengths on the same terms and conditions applicable for the standard lengths during the pendency of the Contract.

12. **QUALITY ASSURANCE PLAN:-**A Quality Assurance Plan including customer hold points covering the manufacturing activities of the material shall be required to be submitted by the bidder to the Employer along with the tender. The Quality Assurance Plan after the same is found acceptable will be approved by the Employer.

The contractor shall follow the approved Quality Assurance Plan in true spirit. If desired by the Employer, he shall give access to all the documents and materials to satisfy the Employer that the Quality Assurance Plan is being properly followed.

13. **TEST CERTIFICATE :-** The bidder must submit the notarized copy of the Type test certificate of the material offered conducted from a NABL accredited Lab. The type test reports shall not be older than FIVE years and shall be valid up to expiry of validity of offer.

14. **TESTS:-** The following tests shall be carried out on sample/samples of conductor.

### 14.1 Type Tests



- (i) Visual examination
- (ii) Measurement of diameters of individual aluminium and steel wires.
- (iii) Measurement of lay ratio of each layer
- (iv) Breaking load test
- (v) Ductility test
- (vi) Wrapping test
- (vii) Resistance test on aluminium wires.
- (viii) DC resistance Test on Composite Conductor.
- (ix) Galvanizing test
- (x) Surface condition test
- (xi) Stress Strain test
- (xii) Procedure qualification test on welded joint of Aluminium Strands.

#### **14.2 Acceptance tests and Routine tests**

- (i) Visual and dimensional check on drum.
- (ii) Visual examination
- (iii) Measurement of diameters of individual aluminium and steel wires.
- (iv) Measurement of lay ratio of each layer
- (v) Breaking load test
- (vi) Ductility test
- (vii) Wrapping test
- (viii) Resistance test on aluminium wires.
- (ix) DC resistance Test on Composite Conductor.
- (x) Galvanizing test

**14.3 Visual examination:-** The conductor shall be examined visually for good workmanship and general surface finish of the conductor. The conductor drums shall be rewound in the presence of Inspecting Officer. The Inspector will initially check for Scratches, Joints etc., and that the conductor shall generally conform to the requirements of the specifications/IS 398(Part-II)-1996.

**14.4 Measurement of diameters of individual Aluminum and Steel Wires.:-**The diameters of individual Aluminium and Steel Wires shall be checked to ensure that they conform to the requirements of this specification.

**14.5 Measurement of lay-ratios:-** The lay-ratios of each layer of the conductor shall be measured and checked to ensure that they conform to the requirements of this specification and IS:398 (Part-II)-1996.

#### **14.6 Breaking load test**

a) **Breaking load test on complete conductor.**

Circles perpendicular to the axis of the conductor shall be marked at two places on a sample of conductor of minimum 5m length between fixing arrangement suitably fixed on a tensile testing machine. The load shall be increased at a steady rate upto 50% of minimum specified UTS and held for one minute. The circles drawn shall not be



distorted due to relative movement of strands. Thereafter the load shall be increased at steady rate to 100% of UTS and held for one minute. The Conductor sample shall not fail during this period. The applied load shall then be increased until the failing load is reached and the value recorded.

**b) Breaking load test on individual Aluminum and Galvanized steel wires.**

This test shall be conducted on both Aluminium and Galvanized steel wires. The breaking load of one specimen cut from each of the samples taken shall be determined by means of suitable tensile testing machine. The load shall be applied gradually and the rate of separation of the jaws of the testing machine shall be not less than 25 mm/min. and not greater than 100 mm. / min. The ultimate breaking load of the specimens shall be not less than the values specified in the Section-II.

**14.7 Ductility Test:**-For the purpose of this test both torsion and elongation tests shall be carried out on galvanized steel wires only.

**14.8 Torsion Test**

One specimen cut from each of the samples taken shall be gripped in two vices exactly 15 cms. apart. One of the vices shall be made to revolve at a speed not exceeding one revolution per second and the other shall be capable of moving longitudinally to allow for contraction or expansion during testing. A small tensile load not exceeding 2 (two) percent of the breaking load of the wire shall be applied to the samples during testing. The test shall be continued until fracture occurs and the fracture shall show a smooth surface at right angles to the axis of the wire. After fracture, the specimen shall be free from helical splits. The sample shall withstand a number of twists equivalent to not less than 18 on length equal to 100 times the diameter. When twisted after stranding the number of complete twists before fracture occurs shall be not less than 16 on a length equal to 100 times the diameter of the wire. In case test sample length is less or more than 100 times the stranded diameter of the strand, the minimum number of twists will be proportioned to the length and if number comes in the fraction then it will be rounded off to the next higher whole number. The fracture shall show a smooth surface at right angles to the axis of the wire.

**14.9 Elongation Test**

The elongation of one specimen cut from each of the samples taken shall be determined. The specimen shall be straightened by hand and an original gauge length of 200 mm. shall be marked on the wire. A tensile load shall be applied as described in 1.1.4.6.2.1 and the elongation shall be measured after the fractured ends have been fitted together. If the fracture occurs outside the gauge marks, or within 25 mm. of either mark or the required elongation is not obtained, the test shall be disregarded and another test conducted. When tested before stranding, the elongation shall be not less than 4 percent and when tested after stranding, the elongation shall be not less than 3.5 percent.

**14.10 Wrapping Test**

This test shall be conducted on both Aluminium and Galvanized steel wires.

**14.11.1 Aluminum wires**

One specimen cut from each of the samples of aluminium wires shall be wrapped round a wire of its own diameter to form a close helix of 8 turns. Six turns shall then be unwrapped and closely wrapped in the same direction as before. The wire shall not break or show any crack.

**14.11.2 Galvanized steel wires**

One specimen cut from each of the samples of galvanized steel wire taken shall be wrapped round a mandrel of diameter equal to 4 times the wire diameter to form a close



helix of 8 turns. Six turns shall then be unwrapped and again closely wrapped in the same direction as before. The wire shall not break.

#### 14.11 Resistance Test

This test shall be conducted on aluminium wires only, conforming to procedure as per IEC: 889. The electrical resistance of one specimen of aluminium wire cut from each of the samples taken shall be measured at ambient temperature. The measured resistance shall be corrected to the value corresponding to 20°C. by means of following formula.

$$R_{20} = R_T [1 / \{1 + \alpha (T - 20)\}]$$

Where,

**R<sub>20</sub> = Resistance corrected at 20°C.**

**R<sub>T</sub> = Resistance measured at T°C.**

**α = Constant mass temperature coefficient of resistance, 0.004.**

**T = Ambient temperature during measurement.**

**This resistance R<sub>20</sub> shall be not more than the maximum value specified in the relevant Indian Standards.**

**14.12 Galvanizing Test:-**This test shall be conducted on galvanized steel wires only. The uniformity of Zinc coating and the weight of coating shall be in accordance with IS 4826-1979.

**14.13 Surface Condition Test:-** A sample of the finished conductor for use in 11/33 KV system having a minimum length of 5 meters with compression type dead end clamps compressed on both ends in such manner as to permit the conductor to take its normal straight line shape, shall be subjected to a tension of 50 percent of the UTS of the conductor. The surface shall not depart from its cylindrical shape nor shall the strands move relative to each other so as to get out of place or disturb the longitudinal smoothness of conductor. The measured diameter at any place shall be not less than the sum of the minimum specified diameters of the individual aluminium and steel strands as indicated in Section-II.

**14.14 Stress-Strain Test:-** The test is contemplated only to collect the creep data of the conductor from the manufacturer. A sample of conductor of minimum 10 meters length shall be suitably compressed with dead end clamps.

#### 15. TEST SET-UP.

- 15.1. The test sample shall be supported in a trough over its full length and the trough adjusted so that the conductor will not be lifted by more than 10mm under tension. This shall be ascertained by actual measurement.
- 15.2. The distance between the clamp and the sleeve mouth shall be monitored with calipers during the test to ensure that, after the test, it does not change by more than 1mm + 0.1mm from the value before the test.
- 15.3. The conductor strain shall be evaluated from the measured displacements at the two ends of the gauge length of the sample. The gauge reference targets shall be attached to the clamps which lock the steel and aluminum wires together. Target plates may be used with dial gauges or displacement transducers and care shall be taken to position the plates





perpendicular to the conductor. Twisting the conductor, lifting it and moving it from side-to-side by the maximum amounts expected during the test should introduce no more than 0.3mm error in the reading.

#### **16. TEST LOADS FOR COMPLETE CONDUCTOR**

The loading conditions for repeated stress-strain tests for complete conductor shall be as follows:

- 16.1. 1KN load shall be applied initially to straighten the conductor. The load shall be removed after straightening and then the strain gauges are to be set At zero tension.
- 16.2. For non-continuous stress-strain data, the strain readings at 1KN intervals at lower tensions and 5 KN intervals above 30% of UTS shall be recorded.
- 16.3. The sample shall be reloaded to 30% of UTS and held for 1 hour. Readings are to be noted after 5, 10, 15, 30, 45 and 60 minutes during the hold period. The load shall be released then after the hold period.
- 16.4. The sample shall be reloaded to 50% of UTS and held for 1 hour. Readings are to be noted after 5, 10, 15, 30, 45 and 60 minutes during the hold period. The load shall be released then after the hold period.
- 16.5. Reloading upto 70% of UTS shall be done and held for 1 hour. Readings are to be noted after 5, 10, 15, 30, 45 and 60 minutes. The load shall be released.
- 16.6. Reloading upto 85% of UTS shall be done and held for 1 hour. Readings are to be noted after 5, 10, 15, 30, 45 and 60 minutes and the load shall be released then.
- 16.7. Tension shall be applied again and shall be increased uniformly until the actual breaking strength is reached. Simultaneous readings of tension and elongation shall be recorded upto 90% of UTS at the intervals described under Clause 16.6.

#### **17. TEST LOADS FOR STEEL CORE ONLY**

The loading conditions for repeated stress-strain tests for the steel core of ACSR shall be as follows:

- 17.1. The test shall consist of successive applications of load applied in a manner similar to that for the complete conductor at 30%, 50%, 70% and 85% of UTS.
- 17.2. The steel core shall be loaded until the elongation at the beginning of each hold period corresponds to that obtained on the complete conductor at 30%, 50%, 70% and 85% of UTS respectively.

#### **18. STRESS-STRAIN CURVES**

The design stress-strain curve shall be obtained by drawing a smooth curve through the 0.5 and 1 hour points at 30%, 50% and 70% of UTS loadings. The presence of any aluminium slack that can be related to any observed extrusion entering the span from the compression dead ends shall be removed from the lower ends of the design curves. Both



the laboratory and standard stress-strain curves shall be submitted to the Employer along with test results. The stress-strain data obtained during the test shall be corrected to the standard temperature i.e. 20 deg. C.

**19. DC RESISTANCE TEST ON COMPOSITE CONDUCTOR**

On a conductor sample of minimum 5m length, two contact clamps shall be fixed with a pre-determined bolt torque. The resistance of the sample shall be measured by a Kelvin double bridge by placing the clamps initially zero meter and subsequently one meter apart. The test shall be repeated at least five times and the average value recorded. The value obtained shall be corrected to the value at 20 deg. C as per clause no. 12.8 of IS:398 (Part-II)-1982/1996. The corrected resistance value at 20 deg. C shall conform to the requirements of this specification.

**20. PROCEDURE QUALIFICATION TEST ON WELDED ALUMINUM STRANDS.**

Two Aluminium wires shall be welded as per the approved quality plan and shall be subjected to tensile load. The breaking strength of the welded joint of the wire shall not be less than the guaranteed breaking strength of individual strands.

**21. CHEMICAL ANALYSIS OF ALUMINUM AND STEEL**

Samples taken from the Aluminium and Steel ingots / coils/ strands shall be chemically/ spectrographically analyzed. The same shall be in conformity with the requirements stated in this specification.

**22. CHEMICAL ANALYSIS OF ZINC:-** Samples taken from the zinc ingots shall be chemically / spectrographically analyzed. The same shall be in conformity with the requirements stated in this specification.

**23. VISUAL AND DIMENSIONAL CHECK ON DRUMS**

The drums shall be visually and dimensionally checked to ensure that they conform to the requirements of this specification.

**24. REJECTION AND RETEST**

24.1. In case of failure in any type test, the Manufacturer is either required to manufacture fresh sample lot and repeat all the tests successfully once or repeat that particular type test three times successfully on the sample selected from the already manufactured lot at his own expenses. In case a fresh lot is manufactured for testing then the lot already manufactured shall be rejected.

24.2. If samples are taken for test after stranding and if any selected reel fails in the retest, the manufacturer may test each and every reel and submit them for further inspection. All rejected material shall be suitably marked and segregated.

**25. CHECKING AND VERIFICATION OF LENGTH OF CONDUCTOR**

The contractor should arrange for inspection by the representative of the Employer specially authorized for this purpose. At least 50% of the total number of drums of conductor subject to minimum of two taken at random should be checked to ascertain the length of conductor. Arrangements should be made available in the works of the manufacturer for transferring the conductor from one reel to another at the same time measuring the length of the conductor so transferred by means of a meter.



**26. ADDITIONAL TESTS**

The Employer reserves the right of having at his own expenses any other test(s) of reasonable nature carried out at Bidder's premises, at site, or in any other standard Laboratory in addition to the aforesaid type, acceptance and routine tests to satisfy himself that the materials comply with the specifications.

**27. TESTING EXPENSES**

- 27.1. The breakup of the testing charges for the type tests specified shall be indicated separately.
- 27.2. Bidder shall indicate the laboratories in which they propose to conduct the type test. They shall ensure that adequate facilities are available in the laboratories and the tests can be completed in these laboratories within the time schedule guaranteed by them.
- 27.3. The entire cost of testing for the acceptance and routine tests and tests during manufacture specified herein shall be treated as included in the quoted unit price of the conductor, except for the expenses of the inspector/Employer's representative.
- 27.4. In case of failure in any type test, if repeat type tests are required to be conducted then all the expenses for deputation of Inspector/Employer's representative shall be deducted from the contract price. Also if on receipt of the Manufacturer's notice of testing, the Employer's representative does not find 'plant' to be ready for testing, the expenses incurred by the Employer for redeputation shall be deducted from contract price.

**28. TEST REPORTS**

- 28.1. Copies of type test reports shall be furnished in at least six copies along with one original. One copy will be returned duly certified by the Employer only after which the commercial production of the material shall start.
- 28.2. Record of Routine test reports shall be maintained by the Manufacturer at his works for periodic inspection by the Employer's representative.
- 28.3. Test certificates of Tests during manufacture shall be maintained by the Manufacturer. These shall be produced for verification as and when desired by the Employer.

**29. TEST FACILITIES**

The following additional test facilities shall be available at the Manufacturer's works:

- (i) Calibration of various testing and measuring equipment including tensile testing machine, resistance measurement facilities, burette, thermometer, barometer, etc.
- (ii) Standard resistance for calibration of resistance bridges.
- (iii) Finished Conductor shall be checked for length verification and surface finish on separate rewinding machine at reduced speed (variable from 8 to 16 meters per minute). The rewinding facilities shall have appropriate clutch system and be free of vibrations, jerks etc with traverse laying facilities.

**30. INSPECTION**

- 30.1. The Employer's representative shall, at all times, be entitled to have access to the works and all places of manufacture where conductor shall be manufactured and the representative shall have full facilities for unrestricted inspection of the Bidder's works,



raw materials and process of manufacture and conducting necessary tests as detailed herein.

- 30.2. The Bidder shall keep the Employer informed in advance of the time of starting and of the progress of manufacture of conductor in its various stages so that arrangements can be made for inspection.
- 30.3. The contractor will intimate the Employer about carrying out of the tests at least 45 days in advance of the scheduled date of tests during which the Employer will arrange to depute his representative/s to be present at the time of carrying out of the tests. Six (6) copies of the test reports shall be submitted.
- 30.4. **No material shall be dispatched from its point of manufacture before it has been satisfactorily inspected and tested, unless the inspection is waived off by the employer in writing. In the later case also, the conductor shall be dispatched only after satisfactory testing for all tests specified herein has been completed and approved by the employer.**
- 30.5. The acceptance of any quantity of material shall in no way relieve the Bidder of any of his responsibilities for meeting all requirements of the specification, and shall not prevent subsequent rejection if such material is later found to be defective.
- 30.6. At least 50% of the total number of drums subject to minimum of two in any lot put up for inspection, shall be selected at random to ascertain the length of conductor by the following method:  
"At the works of the manufacturer of the conductor, the conductor shall be transferred from one drum to another at the same time measuring its length with the help of a graduated pulley and Cyclometer. The difference in the average length thus obtained and as declared by the Bidder in the packing list shall be applied to all the drums if the conductor is found short during checking".

**31. Chemical composition of high carbon steel wire:**

<b>Element</b>	<b>% Composition</b>
i) Carbon	0.5 to 0.85
ii) Manganese	0.5 to 1.10
iii) Phosphorus	Not more than 0.035
iv) Sulphur	Not more than 0.045
v) Silicon	0.10 to 0.35

**32. GUARANTEED TECHNICAL PARTICULARS OF ACSR**

**GUARANTEED TECHNICAL PARTICULARS OF ACSR DOG, RABBIT & WEASEL CONDUCTOR**



(To be furnished by the bidder along with Part-I bid)						
Sl No.	Description					Confirmation
1.	ACSR Conductor shall be manufactured and supplied conforming to Indian Standard Specification IS: 398 (Part I & II) of 1996 with latest amendments and specification contained in the bid document.					
2	Conductor drum shall bear ISI mark					
3	ACSR conductor confirms to size -					
	Name of Conductor or	Stranding & wire dia. In mm	Aluminium Area, mm <sup>2</sup>	Steel Area, mm <sup>2</sup>	Total Area, mm <sup>2</sup>	Total mass in Kg/Km
	WEASEL	<b>6/1/2.59</b>	<b>31.61</b>	<b>5.27</b>	<b>36.88</b>	<b>129</b>
	RABBIT	<b>6/1/3.35</b>	<b>52.88</b>	<b>8.81</b>	<b>61.70</b>	<b>214</b>
	DOG	<b>6/4.72+7/1.57</b>	<b>104.98</b>	<b>13.55</b>	<b>118.5</b>	<b>394</b>
4	Whether following parameters confirm to IS:- 398 (Part II)					
a)	Minimum breaking load of Aluminium wire, after stranding (kN)					
b)	Minimum breaking load of Steel wire (kN)					
c)	Minimum breaking load of completed conductor (kN)					
d)	Mass of conductor (kg / km)					
e)	Resistance of Al. wire at 200C (ohm/km)					
f)	Resistance of conductor at 200 C(ohm/km)					
g)	Modulus of elasticity of conductor (GN/m <sup>2</sup> )					
h)	Co-efficient of linear expansion(per degree c)					
5	Uniformity of galvanizing and mass of Zincoating confirms to Tests as per IS : 4826 /1979					
6	Standard length of conductor shall be as per this specification					
7	Non-standard length shall not be less than 80%, up to 10% of ordered quantity					
8	Wooden packing drums shall confirm toIS:1778					
9	Wooden drums shall have markings as per this specification					



## E. TECHNICAL SPECIFICATION OF M.S STRUCTURAL STEEL SECTION.

**1.1 SCOPE:-** This specification covers the supply/ delivery & transportation of **ISI** marked M.S. Structural Steel Sections (i.e. M.S. Angles & M.S. Channels) conforming to IS: 808/1989 & IS: 2062/2006 and as amended latest.

**1.2 STANDARDS :-**The M.S. Structural Steel Sections (i.e. M.S. Angles & M.S. Channels) shall conform in all respect to the relevant Indian/International Standard Specifications with latest amendments.

### **1.3 SPECIFICATIONS FOR M.S. STRUCTURALSTEEL SECTION (i.e. M.S.ANGLES & M.S.CHANNELS) AS PER IS:808/1989& IS:2062/2006 AND AS AMENDED LATEST.**

- a) Type of Steel Sections: -i)M.S. Angles of sizes (50x50x6)mm & (65x65x6)mm.  
ii) M.S. Channels of Designations MC 75 & MC 100.
- b) Grade of Steel section: - Grade A
- c) Dimensions: - (i) M.S. Angle (50x50x6)mm.  
(ii) M.S. Angle (65x65x6)mm.  
(iii) M.S. Channel (75x40x40x6)mm.  
(iv) M.S. Channel (100x50x50x6)mm.
- d) Tolerance in Dimension (Thickness, Width):- As per IS: 1852/1967 and as amended latest.
- e) Chemical Composition: - Carbon (Maximum):- 0.230%  
Sulphur (Maximum):- 0.045%  
Phosphorus (Maximum):-0.045%  
Manganese (Maximum):- 1.500%  
Silicon (Maximum):- 0.400%
- f) Tensile Strength: - 42 - 54 Kgf /mm<sup>2</sup>
- g) Yield stress (Minimum):- 26.0 Kgf /mm<sup>2</sup>
- h) Length of each section: - 5.0 – 6.0 m
- i) Weight of section: - (i) M.S. Angle (50x50x6)mm = 4.5 Kg/m  
(ii) M.S. Angle (65x65x6)mm = 5.8 Kg/m  
(iii) M.S. Channel, MC 75= 7.14 Kg/m  
(iv) M.S. Channel, MC 100 = 9.56 Kg/m
- j) Elongation (Minimum):- 23%
- k) Tolerances(in Weights):- As per IS:226/1975.

**1.4 SERVICE CONDITIONS:-** The M.S. Structural Steel Sections (i.e. M.S. Angles & M.S. Channels) which are to be supplied for those Specifications shall be suitable for satisfactory continuous operation under the following climatic conditions as per IS: 808/1989 & IS: 2062/2006 or as amended latest.

- i. Location: At various locations in Tripura.
- ii. Max. Ambient air temperature (Deg. C): 45
- iii. Min. Ambient air temperature (Deg. C): 4
- iv. . Max. Average daily ambient air





temperature (Deg. C):	40
v. Max yearly weighted average ambient temperature (Deg. C):	32
vi. Max. Altitude above mean sea level (Meters):	1000 M.

**1.5 TEST CERTIFICATE :-** The bidder shall furnish the type test / the routine test certificates as part of the condition for supply of M.S. Structural Steel Sections (i.e. M.S. Angles & M.S. Channels) from a NABL accredited lab **The type test reports shall not be older than FIVE years and shall be valid up to expiry of validity of offer.**

**Acceptance Tests:**

- (a) Tensile strength test,
- (b) Dimension test along with surface condition.

**Routine Tests:**

- (a) Tensile strength test,
- (b) Dimension test along with surface condition,
- (c) Chemical Composition test.

Sample at random will be selected from the offered lot for the above testing and the lot will be accepted subject to permissible limit of failure as per IS.

Note: Purchaser reserves the right to get all or any type test carried out on one sample of steel section of all sizes each at the cost of supplier from any recognized laboratory / government test house if there arises any dispute regarding the quality of the materials.

**1.6 INSPECTION:-** All tests and inspection shall be made at the place of manufacture unless otherwise especially agreed upon by the manufacturer and purchaser at the time of purchase. The manufacturer shall afford the inspector representing the purchaser all reasonable facilities without charge to satisfy him that the material is being furnished in accordance with the specifications. The purchaser reserves the right to have the tests carried out at the cost of the supplier by an independent agency whenever there arises any dispute regarding the quality of materials.

**1.7 PACKING :-** The M.S. Structural Steel Sections (i.e. M.S. Angles & M.S. Channels) shall be loaded as convenient to the supplier. All Steel Sections (i.e. M.S. Angles & M.S. Channels) shall comply with the dimensions specified. The Steel Sections (i.e. M.S. Angles & M.S. Channels) shall be sound, free from splits, surface flaws, rough jagged and imperfect edges and other harmful surface defects.

The M.S. Structural Steel Sections (i.e. M.S. Angles & M.S. Channels) shall be so supplied that the Steel Sections are adequately protected against damage in ordinary handling and transit. To avoid damage of the Steel Sections transshipment in between the road transportation must be avoided i.e. each consignment should be transported from the factory to worksite/store through a single carrier.

**1.8 MARKING :-** Each Steel Section will bear the following information embossed/metal-tagged on the inner surface of each section:

- a) Manufacturers' name
- b) Manufacturers' Trade mark
- c) Size of section
- d) ISI certification mark, .



**1.9 GUARANTEED TECHNICAL PARTICULARS:-**The Guaranteed Technical Particulars of the M.S. Structural Steel Sections (i.e. M.S. Angles & M.S. Channels) offered shall be given by the bidder along with the tender document.

**1.10 Guaranteed Technical Particulars for M.S. Structural Steel Sections**  
(To be furnished by the Manufacturer)

Sl. No.	Descriptions
1.	Name of Manufacturer: -
2.	Place of Manufacture: -
3.	Type of Steel Sections: -
4.	Grade of Steel Sections; -
5.	Dimensions ( mm): -
6.	Tolerance in Dimensions (Thickness, Width & Weight): -
7.	Chemical Compositions: -
8.	Tensile Strength(Kgf/mm <sup>2</sup> ): -
9.	Yield stress (Minimum): -
10.	Length of each section(mm): -
11.	Weight of sections(Per Metre): -
12.	Elongation (Minimum): -
13.	Reference IS code: -
14.	ISI mark, : -

15. Marking as per Clause No.5.2 of section-IV: -

16. Type Tests certified enclosed:-

Name of Firm .....

Name & Signature  
of the authorized signatory .....  
Designation .....  
Date .....

**F. TECHNICAL SPECIFICATION OF MILD STEEL, PAINTED ,STAY SET.**

**1.1 SCOPE**

This specification covers design, engineering, manufacture, assembly, inspection, testing at manufacturer's workshop before dispatch, packing, supply, delivery and transportation upto



destination of Painted Stay Set for H.T./L.T. line conforming to relevant ISS and Tolerance in the dimensions as per IS:1852/1985 or as amended latest.

## 1.2 STANDARDS

The Painted Stay Set for H.T./L.T. line shall conform in all respect to the relevant Indian/ International Standard Specification, with latest amendments.

### **SPECIFICATION FOR PAINTED STAY SET FOR H.T./L.T.LINE:**

- 1) Type of Stay Set: -16mm.dia Painted Stay Set for H.T. /L.T. line.
- 2) Standard: -IS: 1852/1985 or as amended latest in respect of tolerance in dimensions.
- 3) Anchor Rod:
  - a. Size: - 16mm $\phi$ .
  - b. Length: - 1800mm.exclusive of circular point.
  - c. Thread length: - 50mm.
  - d. Nut:-Hexagonal nut 12mm thick to match the thread of anchor rod.
  - e. Washer: - 40x40x2mm M.S. washer.
  - f. Circular Point: - 40mm $\phi$ .
- 4) Anchor Plate:
  - a. Dimension: - 300x300x8mm M.S.Plate.
  - b. The hole at the centre of the M.S. Plate:-18mm $\Phi$ .
5. Turn Buckle:
  - a. Number of M.S. Rods including Strain rod:-3(three).
  - b. Diameter of Each rod:- 16mm.dia.
  - c. Length of each rod:- 300mm.exclusive of circular point in case of strain rod and excluding the portion to be driven into the solid trapezoidal Caps on both the sides for having forged in case of other two rods.
  - d. Thread length of Strain Rod:-250mm.
  - e. Diameter of each circular points: - 40mm $\phi$ .
  - f. Number of solid trapezoidal Cap made from Square bar:- 2(two).
  - g. Dimension of each Square bar (cap):
    - i). Length of large side:- 72mm.
    - ii). Length of small side:- 30mm.
    - iii).Height:- 28mm.
  - h. Inner distance between the two parallel rods:- 30mm.
  - i. Diameter of hole in the Cap opposite to the Cap holding Strain rod:-18mm. including bush.
  - j. Diameter of Rivet: - 22mm.
  - k. Dimension of M.S. Bush: - 20mm outer dia. X (10mm -11mm) width.
6. Material: - Mild Steel.
7. Painting:-Two coatings of Red Oxide Paint after brushing, scrubbing, Cleaning etc.
8. Dimensions as per Drawing (shown below):-

## 1.3 Diagram of Painted Stay Set



**16mm DIA STAY SETS  
FOR L.T. LINES & 11 KV LINES**

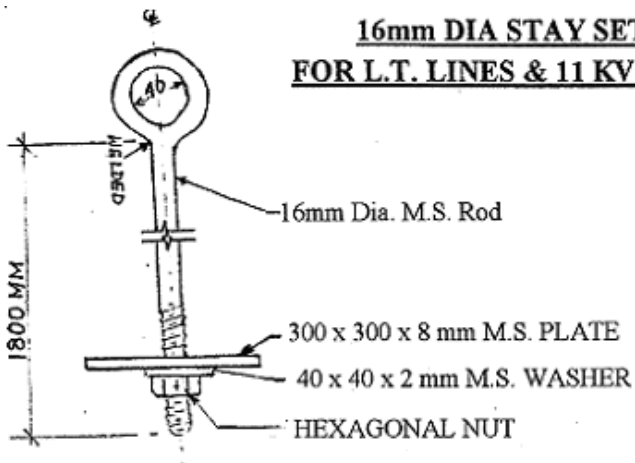

**ANCHOR ROD**

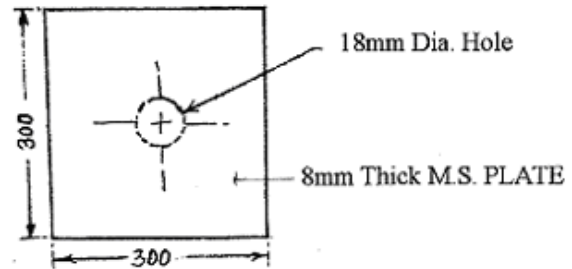

**ANCHOR PLATE**

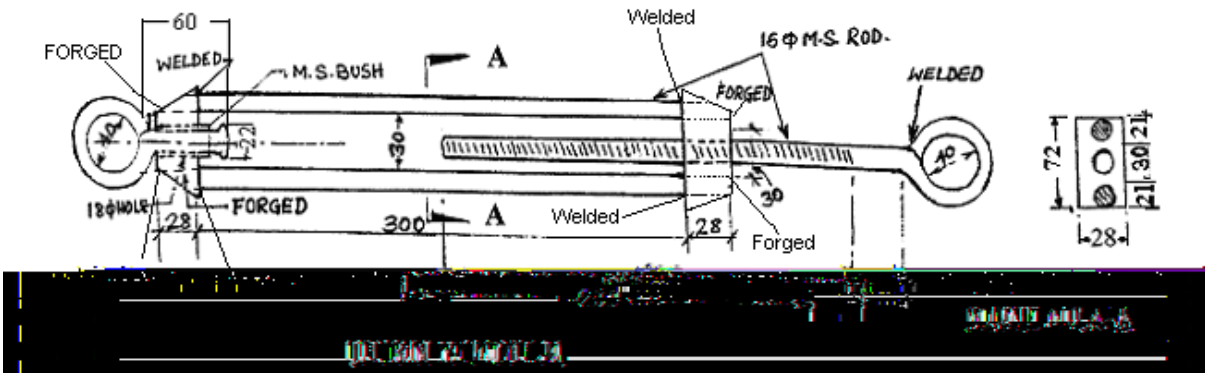

NOTE:- All dimensions are in mm.



## **G. TECHNICAL SPECIFICATION FOR GI STAY WIRE SIZE 7/2.50 MM**

- 1.1 SCOPE:-** This specification covers design, engineering, manufacture, assembly, inspection, testing at manufacturer's workshop before dispatch, packing, supply, delivery and transportation upto destination of the 7/2.50mm Stranded wire.
- 1.2 STANDARDS :-**The G.I. Stranded wires shall comply with the specific requirement of IS-2141/1992, IS-4826/1979.
- 1.3 MATERIAL :-** The wires shall be drawn from steel made by the open hearth basic oxygen or electric furnace process and of such quality that when drawn to the size of wire specified and coated with zinc, the finished strand and the individual wires shall be of uniform quality and have the properties and characteristics as specified in this specification. The wires shall not contain Sulphur and Phosphorus exceeding 0.060 percent each.
- 1.4 TENSILE GRADE :-** The wires shall be grade 4 having minimum tensile strength of 700 N/mm<sup>2</sup> Confirming to IS-2141/1992.
- 1.5 GENERAL REQUIREMENT :-**The lay length of wire strands shall be 12 to 18 times the strand diameter.
- 1.6 MINIMUM BREAKING LOAD :-** The minimum breaking load of the wires before and after stranding shall be as follows.

No. of wires and Const.	Wire Dia (mm)	Min. breaking load of Single Wire before Stranding (KN)	Min. breaking load of the stranded wire (KN).
7 (6/1)	2.50mm	3.44	22.86

### **1.7 CONSTRUCTION.**

- The stay wire shall be of 7 wire construction. The wires shall be so stranded together that when as even distributed pull is applied at the end of completed stand, each wire shall take an equal share of the pull.
- Joints are permitted in the individual wires during stranding but such joints shall not be less than 15 meters part in the finished strands.
- The wire shall be circular and free from scale, irregularities, imperfection, flows, splits and other defect. The zinc coating shall confirm to IS: 4826/1979.

**1.8 TOLERANCE :** -A tolerance of + or - 2.5 % on the diameter of wires before stranding shall be permitted.

**1.9 SAMPLING CRITERIA :**The sampling criteria shall be in accordance with Table-3 Annexure-A IS: 2141/1992.

### **1.10 TESTS ON WIRES BEFORE MANUFACTURE:**



The wire shall be subjected to the following tests in accordance with Is : 2141/1992.

- (1) Ductility test.
- (2) Tolerance on wire diameter.

**1.11 TESTS ON COMPLETED STRAND:** The samples shall be tested for the following tests in accordance with IS: 2141/1992 in addition to other acceptance tests.

a) Tensile and Elongation test.

The percentage elongation of the stranded wire shall not be less than 6 % (Grade-4D)

b) Chemical Analysis:

The manufacturer shall have to submit test certificate with every lot for the chemical composition of the steel rods from which the wires are drawn.

c) Galvanizing test.

The zinc coating shall confirm to "heavy coating" as laid down in IS 4826/1979.

**1.12 PACKING. :**

The G. I. Stay wire shall be supplied in coils. Each coil should be weighing 50 to 70 Kgs. Each coil shall be wrapped in hessian to avoid surface damage to wire during transport and for protection against pollution. Each coil shall be supplied with a metallic tag with on the following particulars shall be printed with water-proof ink/itched.

- 1) Name of Manufacturer.
- 2) Size of G. I. Stay wire.
- 3) Coil Serial No.
- 4) Weight of Coil (approx.)
- 5) Tensile designation.
- 6) Coating.
- 7) A/T No. & Date.
- 8) ISI Mark if any.

**1.13 SEALING.:-**The manufacturer shall keep all the coils ready with seal wire and lead seal so as to enable the Company's inspectors to seal the inspected material immediately. Coils shall then be wrapped with hessian before dispatch.

**1.14 GUARANTEED TECHNICAL PARTICULAR (G.T.P.)**The bidders shall submit guaranteed Technical particulars along with the offer as per enclosed format.

**1.15 DEVIATION FROM SPECIFICATION :**No. deviation in the above specification shall be allowed.

**1.16 GUARANTEED TECHNICAL PARTICULAR:-** Technical information and guaranteed technical particulars for supply of G. I. Stay wire 7/2.5mm size.

**PART - 'A':** Bidder has to conform following important requirements:

<u>Sl.No.</u>	<u>Particulars.</u>	<u>Confirmation.</u>
---------------	---------------------	----------------------

- |    |   |  |
|----|---|--|
| 1. | The G. I. Stay wire 7/2.50mm shall confirm to IS:2141/1992 and 4826/1979 and Company's Specification. |  |
|----|---|--|





2. Quality of Wire shall be hard.
3. The wire shall not contain Sulphur and phosphorous exceeding 0.060 % each.
4. The wire shall be of Grade-4 having minimum tensile strength 700 N/MM<sup>2</sup>
5. The wire shall be of 2.50mm diameter qirt + or - 2.5 % tolerance.
6. The wire shall be circular and free from scale, irregularities, imperfection, flows, splits and other defect.
7. Minimum breaking load of Single wire shall be 3.44 KN.
8. Minimum breaking load of the stranded wire shall be 22.86 KN.
9. Lay Ratio shall be 12 to 18 (RHS)
10. The percentage elongation of the stranded wire shall be 6 % minimum(Grade-4)
11. The wire shall be heavily zinc coated
12. The wire shall be hot dip galvanized as per IS:4826/79
13. The mass of zinc coating shall be 218.5 Gms/m<sup>2</sup> (Minimum)
14. 2 Nos. of 1 minutes dips guaranteed for uniformity test.
15. Weight of each coil shall be from 50 Kg. to 70 Kg.
16. Each coil shall be wrapped in hession to avoid surface damage.
17. Each coil shall be supplied with a metallic tag with following particular shall be printed with water proof ink/itched.
  - a) Name of Manufacturer.
  - b) Size of G. I. Stay wire.
  - c) Coil Serial No.
  - d) Weight of Coil (approx.)
  - e) Tensile designation.
  - f) Coating.
  - g) A/T No. & Date.
  - h) ISI Mark if any.



**H. Technical specification for 8 S.W.G, M.S. Heavy coating Galvanised Iron Wire conforming to IS:280 / 2006 as amended latest , Type of zinc coatingHeavily coated wire (soft) galvanization shall conform to IS : 4826 / 1979as amended latest.**

**1.0 SCOPE:-** This specification covers the design, manufacture, testing at works, supply / deliverytransportation of 8 SWG M.S. heavy coating galvanized Iron Wire conforming to IS:280 / 2006 and as amended latest. Type of zinc coating, heavily coated wire (soft) galvanization shallconform to IS: 4826 / 1979 and as amended latest.

**2.0 STANDARDS**

2.1 The 8 SWG M.S. heavy coating galvanized Iron Wire shall conform in all respect to the relevant Indian / International Standard Specification, with latest amendments.

The standards listed below contain provisions, which through reference in this text constitute provisions of this standard. At the-time of publication, the editions indicated were valid. All standards are subject to revision and parties to agreements based on this standard are encouraged to investigate the possibility of applying the most recent editions of the standards indicated below:

I. S.	Title.
228 (All parts)	Methods for chemical analysis of steels.
1387:1993	General requirements for the supply of metallurgical materials (second revision).
1608:2005	Metallic materials — Tensile testing at ambient temperature (third revision).
1755:1983	Method for wrapping test for metallic wire (First revision).
1956 (Part 5): 1975	Glossary of terms relating to iron and steel: Part 5 Bright steel bar and steel wire.
4826:1979	Hot-dipped galvanized coatings on round steel wires (First revision).
4905:1968	Methods for random sampling.
7887:1992	Mild steel wire rods for general engineering purposes (First revision).
12753:1989	Electro galvanized coatings on round steel wire.

**SPECIFICATION FOR 8 SWG M.S. HEAVY COATING GALVANIZED IRON Wire AS PER IS:280/1978 AND IS: 4826 / 1979 AS AMENDED LATEST.**

1	Type of Wire	:	8 SWG M.S. heavy coating galvanized Iron Wire.
2	Diameter	:	8 SWG (4.06 mm).
3	Tolerance in Diameter	:	± 2.5%.
4	Chemical Composition	:	(i) Carbon % =0.08 to 0.13 ,
			(ii) Mn % = 0.30 to 0.60,
			(iii) S % = 0.05 and
			(iv) Phosphorus % = 0.05.
			(As per IS: 7887 / 1992 and as amended latest).
5	Tensile Strength	:	8 SWG = 45 - 55 Kgf /mm <sup>2</sup> .
6	Mass of Coating	:	8 SWG = 290 g/ m <sup>2</sup> (minimum).
7	Number of dips	:	1minute, 3dips / ½ minute, 1dip.
8	Weight of wire in each	:	50 Kg to 70 Kg.



	coil		
9	Number of wire in each coil	:	Single continuous length.

**3.0SERVICE CONDITIONS:-** The 8 SWG M.S. heavy coating galvanized Iron Wire to be supplied against this Specification shall be suitable for satisfactory continuous operation under the following climatic conditions as per ISS:280/1978 and as amended latest.

i. Location:	At various locations in Tripura.
ii. Max. ambient air temperature (Deg <sup>0</sup> C):	45
iii. Min.ambient air temperature (Deg <sup>0</sup> C):	4
iv. . Max yearly daily ambient air temperature (Deg <sup>0</sup> C):	40
v. Max average weighed average ambient temperature (Deg <sup>0</sup> C):	32
vi. Max. Altitude above mean sea level (Meters):	1000 M.

#### 4.0 TEST AND INSPECTION

4.1 Following tests shall be carried out at the works of the manufacturer as per relevant ISS before

delivery of each lot in presence of the representative of purchaser:

**A. Type Tests:**

Type test shall be carried out as per ISS:280/2006 and as amended latest

**B. Acceptance Tests:**

- (a) Tensile test,
- (b) Hot-Dipped Galvanized Coating Test,
- (c) Wrapping test,
- (d) Dimension test along with surface condition.

**B. Routine Tests:**

- (a) Tensile test,
- (b) Hot-Dipped Galvanized Coating Test,
- (c) Wrapping test,
- (d) Dimension test along with surface condition.
- (e) Chemical Composition test,

Sample at random will be selected from the offered lot for the above testing and the lot will be accepted subject to permissible limit of failure as per IS.

Note : Purchaser reserves the right to get all or any type test carried out on one sample per 400 coils of SWG M.S. heavy coating galvanized Iron Wire at the cost of supplier from any recognized laboratory / government test house.

4.2 The supplier shall furnish **the type test / the routine test** certificates as part of the condition for supply of M.S. heavy coating galvanized Iron Wire in bulk quantity at the discretion of the purchaser.

#### 4.3.0 INSPECTION



- 4.3.1 All tests and inspection shall be made at the place of manufacture unless otherwise especially agreed upon by the manufacturer and purchaser at the time of purchase. The manufacturer shall afford the inspector representing the purchaser all reasonable facilities without charge to satisfy him that the material is being furnished in accordance with specification.
- 4.3.2 The purchaser reserves the right to have the tests carried out at the cost of the supplier by an independent agency whenever there is dispute regarding the quality of supply.

## 5.0 PACKING & MARKING

- 5.1 **PACKING:-**The SWG M.S. heavy coating galvanized Iron Wire shall be supplied in Coils. Each coil of wire shall be suitably bounded and fastened compactly and shall be protected by suitable wrapping with jute cloths. All wires shall be well and cleanly drawn to the dimension specified. The wire shall be sound, free from splits, surface flaws, rough jagged and imperfect edges and other harmful surface defects.

The SWG M.S. heavy coating galvanized Iron Wire coil shall be so packed that the wires are adequately protected against damage in ordinary handling and transit. To avoid damage of the wire transshipment in between the road transportation must be avoided i.e. each consignment should be transported from factory to work site through a single carrier.

- 5.2 **MARKING :-**Each coil will bear the following information with a label fixed firmly on the inner part of the coil:
- Manufacturers' name
  - Manufacturers' Trade mark
  - Coil or identification number
  - Size of Wire
  - Length of Wire
  - Net weight of each coil
  - ISI certification mark if any
  - Year of manufacture TSECL/MMD/2016-17

- 6.0 **GUARANTEED TECHNICAL PARTICULARS:-** The guaranteed technical particulars of the 8 SWG M.S. heavy coating galvanized Iron Wire offered shall be given by the bidder along with the tender.

**Guaranteed & other technical particulars for 8 SWG M.S. heavy coating galvanized iron wire**  
(To be furnished by the Manufacturer)

Sl. No.	Description	NIT requirement	Bidder's offer
1.	Make & Manufacturer		



2.	Place of Manufacturer		
3.	Type of Wire	8 SWG M.S. heavy coating galvanized Iron Wire.	
4.	Diameter (Also in mm)	8 SWG (4.06 mm).	
5.	Tolerance in Diameter	± 2.5%.	
6.	Chemical Composition	(i) Carbon % = 0.08 to 0.13 , (ii) Mn % = 0.30 to 0.60, (iii) S % = 0.05 and (iv) Phosphorus % = 0.05. (As per IS: 7887 / 1992 and as amended latest).	
7.	Tensile Strength	45 - 55 Kgf / mm <sup>2</sup> .	
8.	Mass of Coating	8 SWG = 290 g/ m <sup>2</sup> (minimum).	
9.	Number of dips	1minute, 3dips / ½ minute, 1dip.	
10.	Weight of wire in each coil	50 Kg to 70 Kg.	
11.	Number of piece of wire in each coil	Single continuous length.	
12.	Marking as per clause No.5.2 of section-IV	a) Manufacturers' name b) Manufacturers' Trade mark c) Coil or identification number d) Size of Wire e) Length of Wire f) Net weight of each coil g) ISI certification mark if any h) Year of manufacture TSECL/MMD/2016-17	
13.	Reference IS code		

Signature of Authorized  
Signatory of the firm  
Seal of the firm



## I. TECHNICAL SPECIFICATION FOR 11 KV AIR BREAK GANG OPERATED SWITCH (ROCKING TYPE: 2 POSTS, 200 A RATING) (FOR 11 KV A.C. SYSTEM (VERTICAL))

1. **SCOPE:-** This specification covers the design, manufacture, testing at works, supply/delivery & transportation of outdoor, manual Gang Operated, Rocking Type, single break switch consisting of hot dip galvanized channel iron base, two Nos. post type HT insulators per Pole, electrolytic copper (with silver plating) contacts, hot dip galvanized iron arcing horns capable of breaking the magnetising current complete with horizontal connecting bar, G.I. Pipe, down rod, levers, couplings, operating handle with locking arrangement, marking of 'ON' & 'OFF' position conforming to IS:9921(P-I -IV ) /1981-1985 or its latest amendment including all standard accessories (Fittings) as per specification.
2. **APPLICABLE STANDARD:-** Unless otherwise stipulated in this specifications, the A.B. switches shall conform to IS:1818/1972 & IS:9921(P-I -IV)/1981-85 or its latest amendment.

### **SPECIFICATION FOR G.O.A.B. SWITCH CONFORMING TO IS:9921(P-I to IV)/1981-1985 (ROCKING TYPE:2 POST,200 KVA RATING)**

Sl. No.	PARTICULARS
1	Rated voltage :- 12KV
2	Rated normal current: - 200 Amps.
3	Rated short time current for 1 sec. :-16 KA
4	Frequency :- 50 Hz ( $\pm 3\%$ )
5	Standard of G.O.A.B.Switch:- <b>IS:1818/1972 &amp; IS:9921(P-I to IV)/1981-1985, 9921(P-4 &amp; 5)/1985</b>
6	Phase to phase distance :- 760mm
7	Minimum Isolating Distance:- 300mm
8	<b>G.I. Pipe conforming to IS:1239/79 shall be heavy duty with nominal bore 25mm and 34.2mm O.D.,4.05mm thick,6000mm long Galvanized as per IS:4736/1968 or relevant IS.</b>
9	Post Insulator :- Conforming to IS:2544/1973
10	Galvanization of other steel accessories: - Nuts and bolts, insulator top and exposed part of insulator base shall be of galvanized by hot dip method as per IS: 4736/1968.
11	Galvanization tests to be as per IS: 2633/1972.
12	Fixed contact support shall be phosphor bronze for proper surface contact.
13	Number of break / phase :- Single
14	Number of poles :- three poles
15	Number of post insulator /phase(Pole) :- 02(two) Nos.
16	Type (mounting):- Vertical pole mounting.
17	Type of Insulator :- Post type
18	Number of unit / Stack :- Single stack
19	Number of Units per Set :- 3(three) Units per Set.





	<b>POST INSULATOR conforming to IS:2544/1973</b>
20	Height of post insulator :- 254mm
21	Diameter of post insulator :- 152mm
22	Creepage distance :- 320mm
23	Cap & Pedestal Diameter:-81mm
24	PCD Hole:-57mm
25	Tensile Strength, Kg :- 2050
26	Flash over voltage :- Dry 50 C/S :- 70KV Wet 50 C/S :- 45KV
27	One minute power frequency withstand voltage To earth & between poles :- 28 KV (r.m.s.) Across the isolating distance :- 32 KV (r.m.s.)
28	Impulse 1 x 50 micro sec. (Peak) positive wave :- 90KVp
29	Puncture voltage of unit :- 110KV
30	Net Weight of Post Insulator, Kg (Minimum) :- 4.2
31	Base Channel :- 75 x 40x40x6mm x 508mm Long
32	Dimension of Square Bar made of M.S. Galv. Iron:- 25mm.Sq.side, 1800mm
33	Operating handle Of M.S.Galvanized :- 1No
34	Pad Locking Arrangement of M.S.Galv.:- 1No
35	Braided Flexible tape: - 25x3x1000mm Long.
36	Dimension of rivet: - 25x25x1mm thick rivet in each side of Braided Flexible tape with 10mm dia. hole right in the middle portion of the rivet leaving a length of 7.5mm in each side.
37	Weight of Braided Flexible Tape including strip of rivet: - Not less than <b>360gms.</b>
38	<b>Materials of Braided Flexible tape and rivet:-Tinned Copper</b>
	<b>Moving Contact:</b>
39	Length of Moving contact blade:-170mm
40	Width of Moving contact blade:-28mm
41	Length of Moving contact Base :-75mm
42	Thickness of Moving contact blade& base:-8mm
43	Centre to Centre distance between holes:-57mm
44	Dimension of Moving Arcing Horn:- <b>8mm dia.wire, 190mm long (Minimum) excluding 60mm inner diameter circular portion.</b>
45	Materials:- a. Moving Arcing Horn:-Mild Steel Galvanized, b. Moving contact blade& Base:-Brass.
	<b>Fixed Contact Assembly:</b>
46	(i). Height of Fixed contact strip :- 68mm.
47	(ii). Dimension of Fixed contact strip:-30 x 6mm.thick.
48	(iii).Total Length of Base including Front Terminal Pad:- 150mm.
49	(iv). Thickness of Front Terminal Pad & Base:-8mm.
50	(v). Fixed arcing Horn:- <b>8mm dia.wire, 200mm high x2 Nos.</b>
51	(vi). Centre to Centre distance between holes:-57mm
52	(vii). Materials: a. Contact strip & flexible strip:- Copper,



	b. Front Terminal Pad:- Brass,
	c. Contact Guard & Contact Spring:-M.S. Galvanized.

**N.B.:- Other dimensions are in conformity with the drawing.**

**All Ferrous parts are hot-dip galvanized.**

**All Non-ferrous parts are Electro Silver plated with 8 micron thickness (Minimum).**

**Socket to hold the Operating down rod shall be totally entered in the 'U' shape, strong and robust bracket and thoroughly welded with the latter so far possible. Surface of moving contact assembly & front terminal pad of fixed contact assembly shall be of plain solid surface. In this respect no grooving will be allowed.**

All joints in current carrying path shall be of two bolt type. Each joint shall be provided with one plane and one spring washer of not less than 2 mm thickness even if it is not shown in the drawings.

**2.1.** The handle for operating pipe shall be suitable for gripping by two hands of the operator and the same should be covered with corrugated polythenes /rubber sleeves. 'ON' and 'OFF' indication shall be indelibly marked on weather proof and corrosion proof plates riveted to the body of the handle.

**2.2. Rocking Base:**

M.S. Galvanized box type rocker shall be made from 3mm thick M.S. Sheet x 80mm width. Rocker shall be fitted on the base channel wall through M.S. galvanized studs 12 mm dia which should be passing through glass nylon/ brass bush to be fixed at the side walls of the channel. Moving post insulator to be fitted on the rocker for back and front movement.

**2.3. Flexible Jumper:**

The braided flexible tape will be treated as a part of the Isolator and the temperature – rise should be within allowable limit as per ISS when full load is passed through the isolator. The both ends of the tape will be suitably terminated by tinned copper sockets. They shall be provided with a connector at one end to connect it with Aluminium conductors not exceeding 10 mm dia. and the other end must be securely fixed at the terminal pad of the Rocking insulator with nut/bolt/washer etc. The connectors shall be such as to facilitate easy replacement during future maintenance.

**3. POST INSULATORS:-**

Design and manufacture of post insulator to be used in A.B.Switch assembly should be such as to avoid stress concentration due to direct engagement of the porcelain with the metal fittings and retention of water in the recesses of metal fittings. The post insulator unit shall be assembled in a suitable Jig, to ensure the correct positioning of the top and bottom metal fittings relative to one another. The faces of metal fittings shall be parallel and at right angle to the axis of insulator and corresponding holes on top and bottom metal fittings shall lie in a vertical plane containing the axis of the insulator. The cap and the pedestal must not become loose. The pedestal should be of malleable cast iron and cap should be of malleable cast iron or aluminium. The vertical alignment of post insulator must not vary after operations. The Insulator of M.C.I.Cap and M.C.I. pedestal of post insulators



shall bear the markings of original manufacturers like Biral NGK, BHEL, HTIF, BHEL, Allied Ceramics P. Ltd, India Potteries Ltd, M/s Techno Ceramics or reputed manufacturer. Each post insulator should conform to the requirements of IS: 2544/ 1973 (amended upto date).

**3.1 SAMPLE:-**

**The bidder shall have to supply 2 (two) sets of 2 Post Rocking Type, manual Gang Operated Air Break Switch in finished form as sample within 15(fifteen) days from the date of acceptance of LOA accompanied with a drawing with dimensions in details.**

**3.1 DRAWING: The bidder shall have to submit design and drawing of 2 Post Rocking Type, manual Gang Operated Air Break Switch in finished form with dimensions in details during submission of NIT matching with the drawing attached with the NIT in to.**

**WEATHER CONDITIONS:-**

The 12KV G.O.A.B. Switch to be supplied against the Specification shall be suitable for satisfactory continuous operation under the following climatic conditions as per IS:9921(P-I-IV)/1981-85 or latest revision:

- |  |   |                                 |
|--|---|---------------------------------|
| a) Location  | : | At various locations in Tripura |
| b) Max. ambient air temperature (Deg <sup>0</sup> C)                     | : | 45                              |
| c) Min ambient air temperature (Deg <sup>0</sup> C)                      | : | 4                               |
| d) Max yearly daily ambient air temperature (Deg <sup>0</sup> C)         | : | 40                              |
| e) Max average weighted average ambient temperature (Deg <sup>0</sup> C) | : | 32                              |
| f) Max. Altitude above mean sea level (Meters)                           | : | 1000 M.                         |

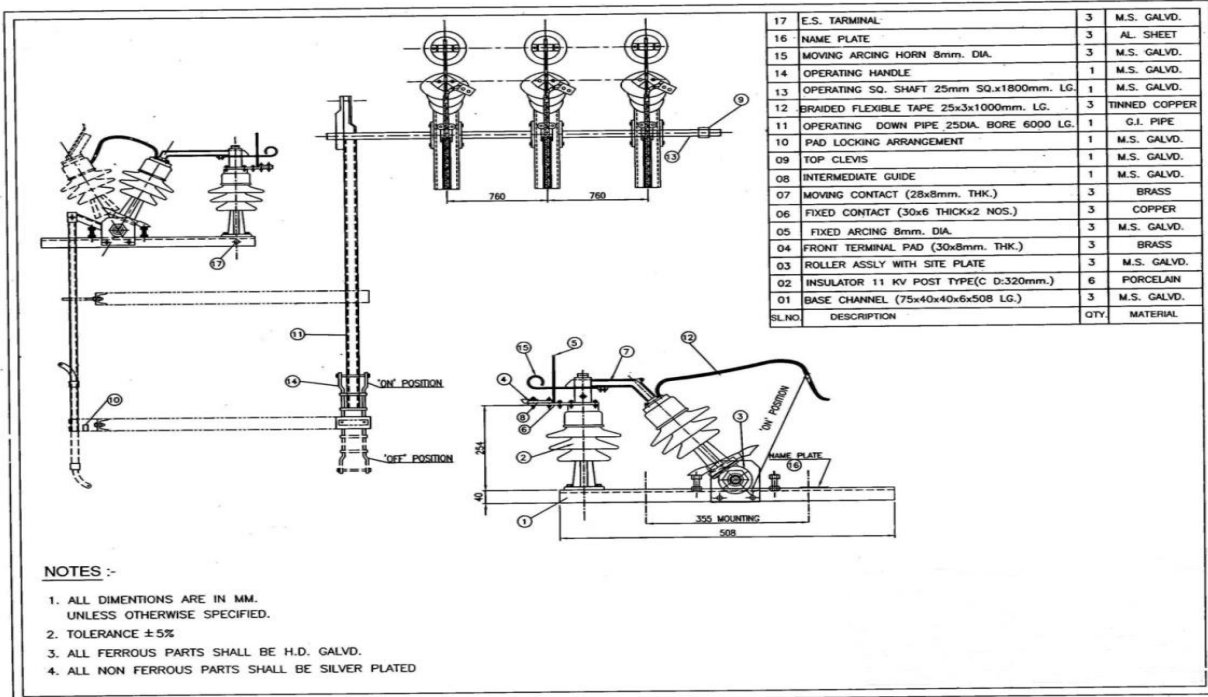

**Figure-1, Rocking Type, 2 Post G.O.A.B. Switch**

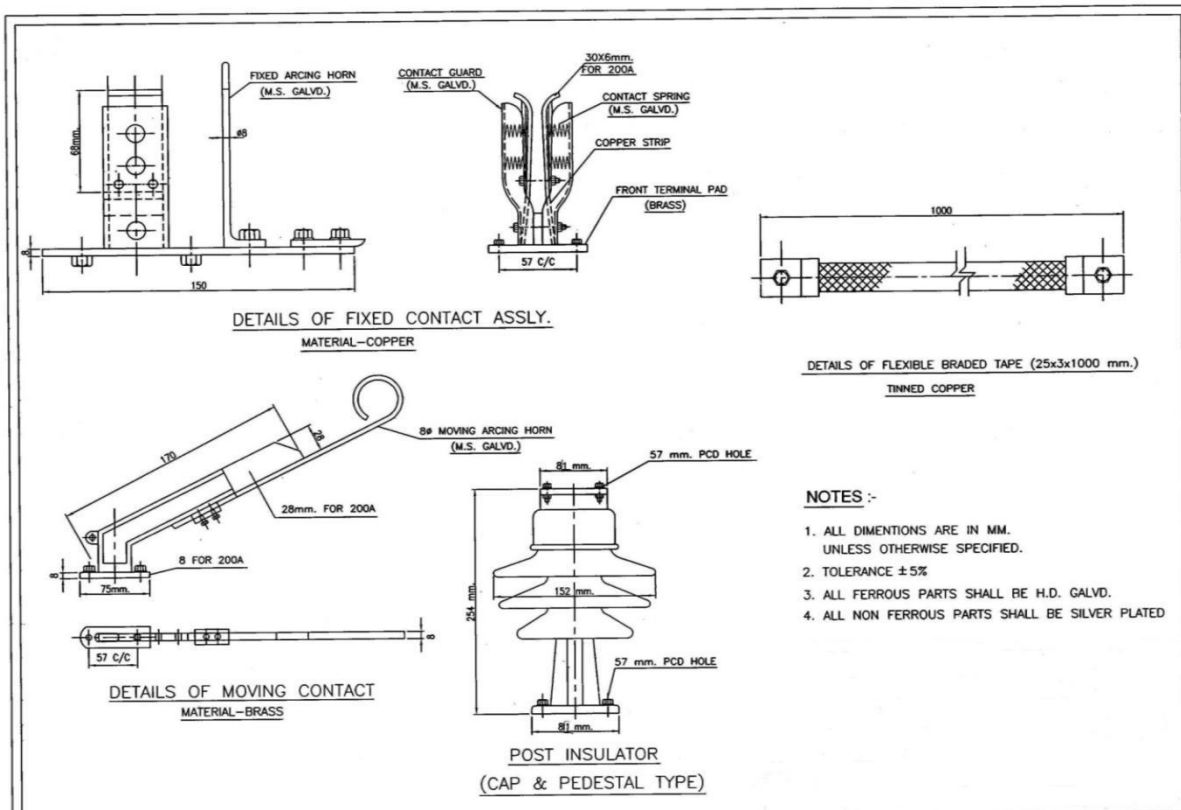



## **Fig-2, Details of G.O.A.B.Switch**

### **4.0 TEST AND INSPECTION**

**4.1 Acceptance Tests:** Following acceptance tests shall be carried out at the works of the manufacturer as per relevant IS before delivery of each lot in presence of the representative of purchaser:-

- (a) Temperature rise test.
- (b) Millivolt drop test.
- (c) 1 min. of power frequency voltage withstand test.
- (d) Operation test: The supplier shall make arrangement for operation test for the total height of the switches on selected samples.
- (e) **Uniformity of silver coating on contact.**
- (f) Dimensional checkup as per drawing and specifications on selected samples.
- (g) **Mechanical test for insulator as per IS: 2544.**

Sample at random will be selected from the offered lot for the above testing and if any one of the test pieces fails, the lot will be rejected. Contact pressure, material / dimensions of the moving / fixed contacts and other components shall also be verified / measured with the approved drawing.

**4.2 Routine Tests:** The following **routine tests** are to be carried out:

- (a) Temperature rise test.
- (b) Millivolt drop test. (For G.O.S.)
- (c) 1 min. of power frequency voltage withstand test.
- (d) Operation test: The supplier shall make arrangement for operation test for the total height of the switches on selected samples.
- (e) Uniformity of silver coating on contact.
- (f) Dimensional checkup as per drawing and specifications on selected samples.

**4.3 Type Tests:** In addition to the routine tests, the complete G.O.S may be required to be tested as per latest edition of IS:1818-1972 and 9921 (Part-I-III&V) 1985 for type test in approved laboratory.

Note : Purchaser reserves the right to get all or any type test carried out on one sample per 100 Sets of 12KV G.O.A.B. Switch and D.O. Fuse unit at the cost of supplier from any recognized laboratory/ government test house.

**4.4** The supplier shall furnish the type test as well as the routine test certificates as part of the condition for supply of switches in bulk quantity at the discretion of the purchaser.

#### **4.5.0 INSPECTION**

**4.5.1** All tests and inspection shall be made at the place of manufacture unless otherwise especially agreed upon by the manufacturer and purchaser at the time of purchase. The manufacturer shall afford the inspector representing the purchaser all reasonable facilities without charge to satisfy him that the material is being furnished in accordance with specification. The bidder should clearly specify the testing facility available for electrical, mechanical, ceramic and metallurgical tests.

**4.5.2** The purchaser reserves the right to have the tests carried out at the cost of the supplier by an independent agency whenever there is dispute regarding the quantity of supply.



## 5.0 PACKING & MARKING

### 5.1 PACKING

12KV Rocking Type G.O.A.B. Switch shall be delivered suitably packed. Although the method of packing is left to the discretion of the manufacturer it should be robust enough for rough handling that is occasioned during transportation by road and to avoid damage and breakage of the insulator trans-shipment in between the road transportation must be avoided i.e. each consignment should be transported from factory **to work site storeyard**

### 5.2 MARKING

The following information shall be **engraved** on the Base Channel & Operating pipe:

- i) Manufacturers' Trade mark
- j) The Manufacturers' name

## 6.0 GUARANTEED TECHNICAL PARTICULARS

The guaranteed technical particulars of the 12KV Rocking Type G.O.A.B. Switch offered shall be given by the bidder along with the tender.

## 7. Guaranteed & other technical particulars for G.O.A.B. Switch

(To be furnished by the Manufacturer)

Sl. No.	PARTICULARS
1	Make & Manufacturer
2	Place of Manufacture
3	Rated voltage
4	Rated normal current
5	Rated short time current for 1 sec.
6	Frequency:
7	Standard of G.O.A.B.Switch
8	Phase to phase distance
9	Minimum Isolating Distance
10	<b>G.I. Pipe Dimension &amp; IS</b>
11	Standard of Post Insulator :
12	Galvanization of other steel accessories/ IS
13	Galvanization tests to be as per IS:
14	Material of Fixed contact support
15	Number of break / phase
16	Number of poles
17	Number of post insulator /phase(Pole)
18	Type (mounting
19	Type of Insulator
20	Number of unit / Stack
21	Number of Units per Set
	<b><u>POST INSULATOR</u></b>
22	Height of post insulator
23	Diameter of post insulator
24	Creepage distance
25	Cap & Pedestal Diameter





26	PCD Hole
27	Tensile Strength, Kg
28	Flash over voltage :- Dry 50 C/S Wet 50 C/S
29	One minute power frequency withstand voltage To earth & between poles Across the isolating distance
30	Impulse 1 x 50 micro sec. (Peak) positive wave
31	Puncture voltage of unit
32	Net Weight of Post Insulator, Kg (Minimum)
33	Dimension of Base Channel
34	Dimension of Square Bar made of M.S. Galv.Iron
35	No of Operating handle Of M.S.Galvanized
36	No of Pad Locking Arrangement of M.S.Galv.
37	Braided Flexible tape:
38	Dimension of rivet
39	Weight of Braided Flexible Tape including strip of rivet
40	<b>Materials of Braided Flexible tape and rivet</b>
	<b>Moving Contact:</b>
41	Length of Moving contact blade
42	Width of Moving contact blade
43	Length of Moving contact Base
44	Thickness of Moving contact blade& base
45	Centre to Centre distance between holes
46	Dimension of Moving Arcing Horn
47	Materials:- a. Moving Arcing Horn b. Moving contact blade& Base
	<b>Fixed Contact Assembly:</b>
48	(i). Height of Fixed contact strip
49	(ii). Dimension of Fixed contact strip
50	(iii).Total Length of Base including Front Terminal Pad
51	(iv). Thickness of Front Terminal Pad & Base
52	<b>(v). No &amp; Dimension of Fixed arcing Horn</b>
53	(vi). Centre to Centre distance between holes
54	(vii). Materials: a. Contact strip & flexible strip b. Front Terminal Pad c. Contact Guard & Contact Spring

Signature of Authorized  
Signatory of the firm  
Seal of

the firm.

**J. TECHNICAL SPECIFICATION FOR 12KV, 200A D.O. FUSE UNIT FOR 11KV A. C. SYSTEM (VERTICAL)**

**1.0 SCOPE:-D.O. Fuse Unit:-**This specification covers the design, manufacture, testing at works, supply/ delivery & transportation of outdoor, triple pole, expulsion type, rewire-able Drop Out Fuse Unit complete with two post insulators per pole, contact parts of phosphor bronze spring with other non-ferrous metal parts heavily tinned with SRBP tube suitable for fuse conforming to IS:5792 & 9385 (PI-III)/1979 and suitable for vertical mounting on structures, F.O.R. at work site store yard

**2.0 STANDARDS :-**The 12KV D.O. Fuse Unit / materials shall conform in all respect to the relevant Indian/International Standard Specification, with latest amendments.

**SPECIFICATION FOR D.O. Fuse Unit IS:5792 & 9385 (PI-III)/1979**

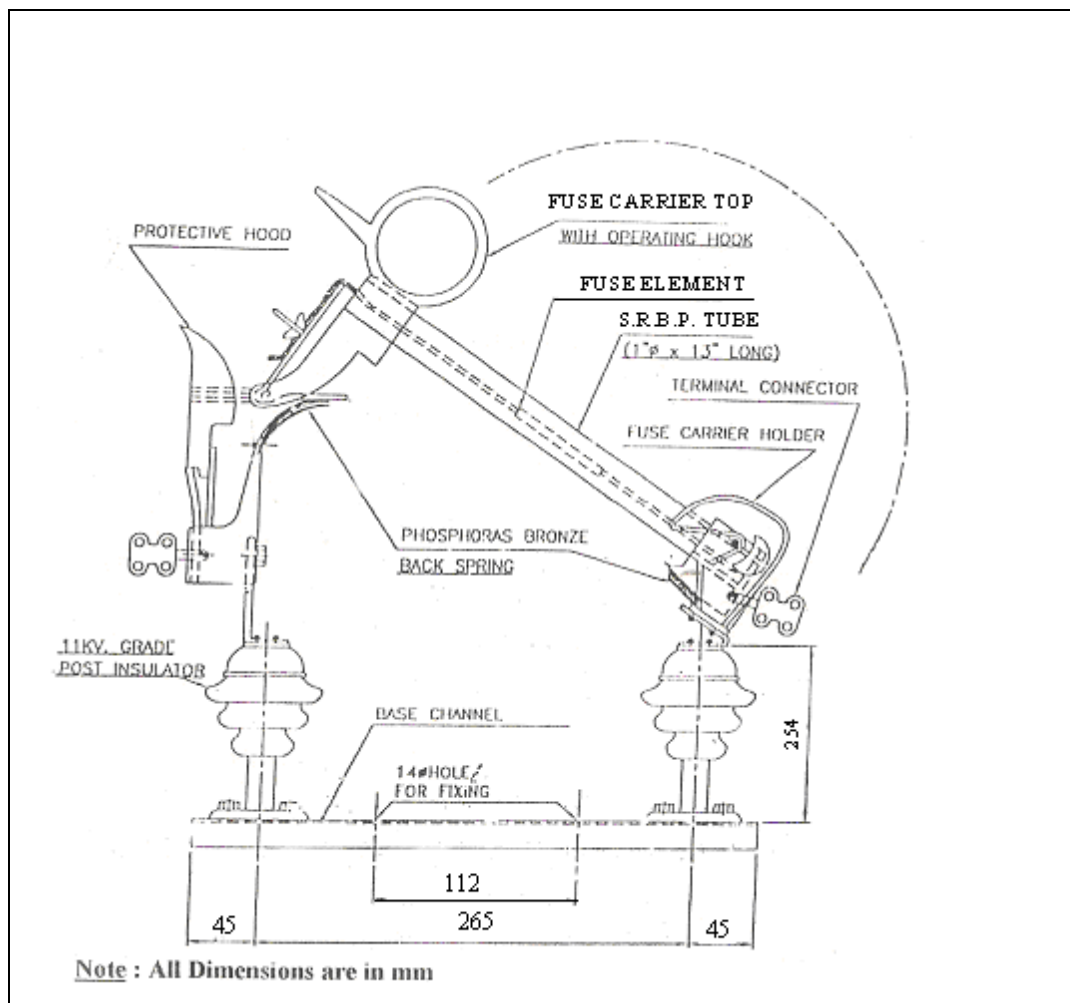

**Fig-3, Drop Out Fuse Unit.**



### **D.O. Fuse Unit**

<b>Sl. No.</b>	<b>PARTICULARS</b>
1	Rated voltage :- 12KV
2	Rated normal current: - 100 Amps.
3	Frequency :- 50 Hz
4	Phase to phase distance :- 760mm
5	Channel base nuts and bolts, post insulator top and exposed portion of insulator base etc, steel parts shall be galvanized by hot deep method as per IS:4736/1968.
6	Post Insulator :- Conforming to IS:2544/1973
7	Galvanisation test shall be as per IS: 2633/1972.
8	Standard :- Conforming to IS:9385
9	Number of break / phase :- one
10	Number of poles :- Triple pole
11	Number of post insulator /phase :- 2(Two) Nos. 11KV Post insulator
12	Type of contacts :- Fixed type
13	Type (mounting) :- Vertical pole mounting.
14	Type of Insulator :- Post type
15	Number of unit / Stack :- Single stack
16	Height of post insulator :- 254mm
17	Flash over voltage :- Dry 50 C/S :- 70KV Wet 50 C/S :- 45KV
18	One minute power frequency withstand voltage To earth & between poles :- 28 KV (r.m.s.) Across the isolating distance :- 32 KV (r.m.s.)
19	Impulse 1 x 50 micro sec. (Peak) positive wave :- 90KVp
20	Puncture voltage of unit :- 110KV
21	Creepage distance of Post insulator :- 320mm
22	Cap & Pedestal Diameter of Post insulator:-83mm
23	PCD Hole of Post insulator:-57mm
24	Tensile Strength of Post insulator, Kg :- 2050
25	Net Weight of Post Insulator, Kg (Minimum) :- 4.2
26	Base Channel :- 75 x 40x40x6mm
27	Material of Terminal Connector :- Brass
28	Weight of Terminal Connector (excluding Nuts & Bolts) :- 90 gm (Minimum)

### **SERVICE CONDITIONS**

The 12KV D.O.Fuse Unit to be supplied against this Specification shall be suitable for satisfactory continuous operation under the following climatic conditions as per IS:5792 & 9385 (PI-III)/1979 or latest revision.

- i. Location : At various locations in Tripura.
- ii. Max. ambient air temperature (Deg<sup>0</sup> C) : 45
- iii. Min ambient air



- temperature (Deg<sup>0</sup> C) : 4
- iv. Max yearly daily ambient air temperature (Deg<sup>0</sup> C) : 40
- v. Max average weighed average ambient temperature (Deg<sup>0</sup> C) : 32
- vi. Max. Altitude above mean sea level(Meters) : 1000 M.

### 3.0 TEST AND INSPECTION

3.1 **Acceptance Tests:** Following acceptance tests shall be carried out at the works of the manufacturer as per relevant IS before delivery of each lot in presence of the representative of purchaser:-

- (a) Temperature rise test.
- (b) Millivolt drop test. (For D O F)
- (c) 1 min. of power frequency voltage withstand test.
- (d) Operation test: The supplier shall make arrangement for operation test for the total height of the switches on selected samples.
- (e) Uniformity of silver coating on contact.
- (f) Dimensional checkup as per drawing and specifications on selected samples.
- (g) Sample at random will be selected from the offered lot for the above testing and if any one of the test pieces fails, the lot will be rejected. Contact pressure, material / dimensions of the moving / fixed contacts and other components shall also be verified / measured with the approved drawing.

3.2 **Type Tests:** In addition to the routine tests, the complete D.O.F. unit may be required to be tested as per latest edition of IS:1818-1972 and IS:9385(Part I-III) (for D.O.F. unit) for type test in approved laboratory.

Note: Purchaser reserves the right to get all or any type test carried out on one sample per 100 Sets of 12KV G.O.A.B. Switch and D.O. Fuse unit at the cost of supplier from any recognized laboratory/ government test house.

3.3 The supplier shall furnish the type test as well as the routine test certificates as part of the condition for supply of switches in bulk quantity at the discretion of the purchaser.

### 3.4 INSPECTION

3.4.1 All tests and inspection shall be made at the place of manufacture unless otherwise especially agreed upon by the manufacturer and purchaser at the time of purchase. The manufacturer shall afford the inspector representing the purchaser all reasonable facilities without charge to satisfy him that the material is being furnished in accordance with specification. The bidder should clearly specify the testing facility available for electrical, mechanical, ceramic and metallurgical tests.

3.4.2 The purchaser reserves the right to have the tests carried out at the cost of the supplier by an independent agency whenever there is dispute regarding the quantity of supply.

### 4.0 PACKING & MARKING

#### 4.1 PACKING



12KV D.O. Fuse unit shall be delivered suitably packed. Although the method of packing is left to the discretion of the manufacturer it should be robust enough for rough handling that is occasioned during transportation by road and to avoid damage and breakage of the insulator trans-shipment in between the road transportation must be avoided i.e. each consignment should be transported from factory to **work site Storeyard**

#### 4.2 MARKING

A. The following information shall be **engraved** on the Base Channel & Operating pipe:

- a) Manufacturers' Trade mark
- b) The Manufacturers' name
- c) Visible marking "TSECL/TLM/2014-15"

#### 5.0 GUARANTEED TECHNICAL PARTICULARS

The guaranteed technical particulars of the 12KV D.O.Fuse unit offered shall be given by the bidder along with the tender.

##### **Guaranteed & other technical particulars for** (To be furnished by the Manufacturer)

#### 1. D.O. Fuse Unit

Sl. No.	Description
1	Rated voltage :
2	Rated normal current :
3	Frequency :-
4	Phase to phase distance :
5	Method of Galvanisation of Channel base nuts and bolts, post insulator top and exposed portion of insulator base etc & steel parts.
6	Post Insulator / Standard :
7	Galvanization test
8	Number of break / phase :
9	Number of poles :
10	Number of post insulator /phase :
11	Type of contacts :
12	Type (mounting) :
13	Type of Insulator :
14	Number of unit / Stack :
15	Height of post insulator :
16	Flash over voltage :- Dry 50 C/S : Wet 50 C/S :
17	Impulse 1 x 50 micro sec. (Peak) positive wave :
18	Puncture voltage of unit :
19	Creepage distance of Post insulator :
20	Tensile Strength of Post insulator, Kg:
21	PCD Hole of Post insulator:
22	Net Weight of Post Insulator(Minimum),Kg :
23	Dimension of Base Channel :



- 24 Material of Terminal Connector :  
25 Weight of Terminal Connector:

Signature of Authorized  
Signatory of the firm  
Seal of the firm

## K. TECHNICAL SPECIFICATION OF GAPLESS LIGHTNING ARRESTORS FOR 11 KV AND 33 KV SYSTEM

### 1.0 SCOPE:

This specification covers design manufacture assembly, testing at manufacturers works supply and delivery of single phase outdoor metal oxide **polymeric** housed distribution type gapless surge arresters for use in effectively earthed system with the transformer neutral effectively earthed with normal voltage of 11KV for 9KV Lightning arrestors. The rated voltage of Arrestors shall be 9KV (rms) for 11KV system.

### 2.0 CLIMATIC CONDITIONS:-

(i)	Location	In the State of
(ii)	Maximum Ambient Air Temperature Deg.C	45
(iii)	Minimum Ambient Air Temperature Deg. C	2
(iv)	Average Daily Ambient Air Temperature Deg. C	32
(v)	Maximum Relative humidity (%)	90
(vi)	Average rainfall per annum (mm)	1200
(vii)	Maximum Altitude above mean sea level (meters)	Not more than 1000 meters (Average 200 to 600 Mtrs)
(viii)	Isoceraunic level (Day/annum)	20/50
(ix)	Maximum Wind Pressure (kg/sq. meters)	45
(x)	Seismic level (Horizontal acceleration)	0.1 g

### 3.0 SPECIAL CONDITIONS:-

The atmosphere at places is laden with dust in suspension during the dry months and subject to fog in cold months. The temperature variation between the daily minimum and maximum is large. Heavy lightning is usual in the area during the month of March to November. The area is also subjected to heavy monsoon rains 80% to 90% of the annual participation during the months of June to October.

### 4.0 SYSTEM CONDITIONS:-

(i)	Nominal system voltage	33KV	11KV
(ii)	Highest system voltage	36KV	12KV
(iii)	Frequency	50Hz	50 Hz
(iv)	Fault level	1500 MVA	250 MVA

- 4.1 The system is 3 phase 50 Hz solidly grounded system with earth fault protection. The winding of transformer which is to be protected is connected in delta formation.





4.2 The insulation level provided in our transformer is 170KVp for 33KV System and in case of 11KV System, 75KVp.

**5.0 STANDARD:-**

The surge arresters shall strictly conform to IEC 99-4 /IS-3070 Part-3 - 1993 with latest amendment if any in all respects. Maximum residual voltage shall comply with the requirement given hereunder.

The surge arresters meeting any other authoritative standards which ensure equal or better performance than mentioned above shall be acceptable.

The technical requirement have been detailed out below:

6.0 The supplier should offer nearest rating of surge arresters.

6.2 The transformers, which are to be protected having BIL 170 KVp for 33KV winding & 75 KVp for 11KV winding. We will be installing our LAs at a distance of 5/10 meters from transformer (another 5 meters be added towards height of LAs lead length and bushing of transformers). Considering 20% safe margin as per IEC the impulse voltage of more than 136 KVp should not appear across the 33 side of transformer. Similarly, impulse voltage of more than 60 KVp should not appear across 11KV winding of transformer.

6.3 Required Technical particulars:

Sr. No.	Particulars	Requirements		
		33KV	11KV	11KV
1.	Nominal system voltage	33KV	11KV	11KV
2.	Type of Arrestor	Gap-less (Metal Oxide) Station Type	Gap-less (Metal Oxide) Station Type	Gap-less (Metal Oxide) Distribution type for Lines
3.	Applicable Standard	IEC 99/4 IS 3070 Part-III latest Amendment.		
4.	Rated Arrestor voltage KV rms	30	9	9
5.	Maximum continuous operating voltage KVrms	24	7.65	7.65
6.	Nominal discharge current rating (8/20 micro sec) KA	10.0	10.0	5.0
7.	Minimum discharge capability (KJ/KV)	As per long duration discharge class 2 of IEC 99/4		Distribution class
8.	Long duration discharge class	2	2	2
9.	Maximum residual voltage at nominal discharge current of 8/20 micro sec. wave, KV peak	85	27	32
10.	Maximum steep current impulse residual voltage at nominal discharge current, KV Peak	93	36	38
11.	Maximum switching impulse residual voltage at 500 Amp. (Peak)	70	24	NA
12.	Minimum prospective symmetrical current (KA)	40	15	15
13.	Impulse high current short duration discharge of 4/10 micro sec. wave (KAP)	100	100	65
14.	Max. radio interference voltage	1000	--	--



	at 1000 Hz (micro volts)			
15.	Overall temporary over voltage withstand capacity (KVrms)			
	a) 1.0 Sec.	36	10	10
	b) 10.0 Sec.	34	9.5	9.5
	c) 100.0 Sec.	32	9.0	9.0
16.	Impulse withstand voltage (KVP)	170	75	75
17.	Current impulse withstand level	As duty prescribed in line discharge <b>class-II</b> of IEC TC-37/IS 3070 Pt-III.	18 impulse of long duration Current 75 Amp peak for 1000 micro secs.	18 impulse of long duration Current 75 Amp peak for 1000 micro secs.
18.	Disconnecting device	Not applicable	As per required specification IS:3070 (Part 2) 1985	
19.	Min. creepage distance of porcelain housing (mm)	900	300	300
20.	Terminal arrangement	Built in clamping Type, can be adjusted for Horizontal & Vertical take off and suitable for Panther/Dog/Raccoon Conductor for 33 KV and 11 KV substation type LAs and Rabbit for 11 KV distribution type LAs..		

- 6.4 Residual voltage for 8/20 micro sec. wave of nominal discharge current KA are specified above, however, we will prefer still lower residual voltage to ensure better protection.
- 6.5 The requirement of energy is very specific based on our system. The firms are requested to offer nearest energy rating of LAs for both single and double shot.
- 6.6 Current impulse withstands level - The 9KV arrestors shall withstand 18 impulse of long duration current with a peak level of 75 Amp. & duration 1000 micro secs. 30KV arrestors shall with stand - impulse of long duration current with a peak level of 175 Amp. & duration 2000 micro secs

**7.0 Disconnecting Device: -**

- 7.1 The arrestor shall be provided with a suitable disconnecting device. This shall be connected in series with the ground lead and should not affect the sealing system of the arrestor. The disconnecting device shall conform to the requirement specified in IS:3070 (Part-II)1993 & IEC 99 - 4 (1991-II) clause 5.12, 7.6.3.
- 7.2 A surge arrester having one or several non-linear metal-oxide resistors with highly non-linear voltage-current characteristics, in series, but having no integrated series or parallel spark gaps.
- 7.3 A surge arrester with a housing made of polymeric material without air voids neither between the housing and the metal-oxide resistors nor the housing itself.  
The surge Arrester housing shall be made with silicone Rubber (Polymeric) of reputed manufacturer. The Silicone rubber used for housing should pass the tracking & erosion test of 4.5kv as per IEC 587. The surge arrester should be made without any internal gas volume.  
The adhesion between the polymeric housing and the metal-oxide resistors or any other metallic or non-metallic parts inside the housing must be strong enough, homogeneous, robust and resistant to thermal cycles and environmental stresses.
- 7.4 All the units of arresters of same rating shall be interchangeable type without adversely affecting the performance.



- 7.5 All necessary bolts, nuts clamps etc., required for mounting on support structure shall be included in the scope of supply.
- 7.6 The polymer material which is used for the arrester housing must be tracking and erosion resistant, stabilized against UV radiation and have proven records in similar applications (like MV/HV cable terminations, insulators and arresters) in country.
- 7.7 All exposed ferrous parts shall be hot dip galvanized as per IS:2633.
- 7.8 Line terminal pads and ground terminal pads should be hot dip galvanized.

#### 8.0 TERMINAL CONNECTORS:-

Terminal connectors shall be manufactured and tested as per IS:5361 and should be type tested. The terminal connector drawings should be submitted separately with the tender documents.

- 8.1 All casting shall be free from blow holes, surface blisters, cracks and cavities. All sharp edges and corners shall be blurred and rounded off.
- 8.2 All current carrying parts shall be designed and manufactured to have minimum contact resistance.
- 8.3 The contact surface must be machined smooth to obviate excessive current density.
- 8.4 The terminal connector for connection of conductor should be suitable for ACSR/AAAC Panther/Dog/Raccoon Conductor for 33 KV and 11 KV substation type LAs and Rabbit/Weasal for 11 KV distribution type LAs with Universal take off arrangement (can be adjusted for both horizontal & vertical take off) and should have adequate current carrying capacity.
- 8.5 The terminal connector shall be manufactured out of Aluminum alloy grade LM 9 or 25 as per IS and by gravity die casting process only.
- 8.6 The base of the polymer lightning arrestors shall be provided with to separate terminal distinctly make for connection to earth.

#### 9.0 NAME PLATE:

The arresters shall be provided with non-corrosive legible name plate fitted rigidly at arrester body with indelibly marked with the following information :-

- (i) TSECL
- (ii) Order No. & date.
- (iii) Manufacturer's name or trade mark and identification Serial Number of the Arrester.
- (iv) Rated voltage.
- (v) Maximum continuous operating voltage.
- (vi) Type
- (vii) Rated frequency
- (viii) Nominal discharge current
- (ix) Long duration discharge class
- (x) Pressure relief current in KA rms.
- (xi) B.I.L. of the equipment to be protected
- (xii) Year of manufacture

The nameplate should be fitted rigidly so that during life of arrester, there should not be any possibility of removal of name plate.

#### 10.0 DRAWINGS:-



The supplier shall furnish two sets of following drawings for our approval before commencing the supplies:-

- i) General outlines drawings of the complete arrester with technical parameters.
- ii) Drawings showing clearance from grounded and other live objects and between adjacent poles of surge arresters required at various heights of surge arresters.
- iii) Mounting clamp details of surge arresters.
- vi) Details of line terminal and ground terminals.
- v) Volt time characteristics of surge arresters.
- vi) The detailed dimensional drawing of polymer housing such as ID, OD, thickness and insulator details such as height, profile of petticoats angle of inclination and gap between successive petticoats total creepage distance etc.

#### **11.0 TESTS & TEST CERTIFICATES:**

11.1 Type Test Certificates :- The complete type test certificate issued by any NABL accredited laboratory for the LAs of all the types/rating as per IEC 99/4 shall compulsorily be submitted in support of evidence of compliance of the specifications & guaranteed particulars. It should cover all the type tests as prescribed in Clause 7.1 of IEC 99/4 and IS-3070 (Part-III).

Note:- Type test report of manufacturer's laboratory shall not be acceptable.

#### **11.2 Type Tests:-**

(A) The following type tests shall be made in accordance with Clause 7.1 of IEC 99/4/IS-3070 Part-III latest amendment:-

1. Insulation withstand test.
2. Residual voltage test
3. Long duration current impulse withstand test
4. Operating duty test
5. Test of Arrestor Dis-connectors
6. Partial discharge test.
7. Accelerated Ageing test
8. Power frequency VS time characteristics

(B) The following additional tests are to be made in accordance with IS 3070 (part-II) 1985:-

1. Moisture Ingress test
2. Weather aging test
3. Galvanizing test on steel metal parts.

(C) For Energy Calculation, set of Type Test Reports should be submitted.

#### **11.3 ACCEPTANCE TESTS:**

The following tests as per clause 8.2 of IEC 99/4 and IEC 99/4 IS-3070 Part-I & Part-II shall be done on the lower whole number of the cube root of the number of arresters to be supplied.

- a) Power frequency reference voltage test at reference current on complete arresters.
- b) Lightning impulse residual voltage test at nominal discharge current on complete arresters.



- c) Partial discharge test.
- d) Galvanizing test on exposed steel parts.
- e) Visual/dimensional examination.

**11.4 ROUTINE TESTS:-**

The following routine tests as per Clause 8.1 of IEC 9/4 / IS-3070 Part-1/Part-III are to be conducted by the manufacturer on offered lot for pre-despatch inspection. The lot offered without routine test reports shall not be considered & delay in acceptance of the offer will be on firm's account:-

- a) Measurement of the reference voltage on the complete arresters.
- b) Residual voltage test at nominal discharge current on the complete arresters or sections.
- c) Test to verify the efficacy of sealing.
- d) Partial Discharge test

**12.0 INSPECTION:-**

- 12.1 The purchaser's representative shall at all times be entitled to have access to the works and all places of manufacture where equipment/material shall be manufactured and the representative shall have full facilities for unrestricted inspection of the supplier's works raw materials and process of manufacture for conducting necessary tests as detailed herein.
- 12.2 The supplier shall keep the purchaser informed in advance of the time of starting and of the progress of manufacture of equipment/material in its various stages so that arrangements can be made for inspection.
- 12.3 No material shall be dispatched from its point of manufacture before it has been satisfactorily inspected and tested, unless the inspection is waived off by the purchaser in writing. In the later case also, the equipment/material shall be dispatched only after satisfactory testing for all tests specified herein has been completed.
- 12.4 The acceptance of any quantity of material shall in no way relieve the supplier of any of his responsibilities for meeting all requirements of the specification, and shall not prevent subsequent rejection if such material is later found to be defective.
- 12.5 The number of sample selected to carryout the acceptance test shall be as per provision in the respective IS.
- 12.6. The purchaser has the right to have the tests carried out by an independent Agency subject to recovery of testing expenditure in case of failure, whenever there is dispute regarding the quality of supply.

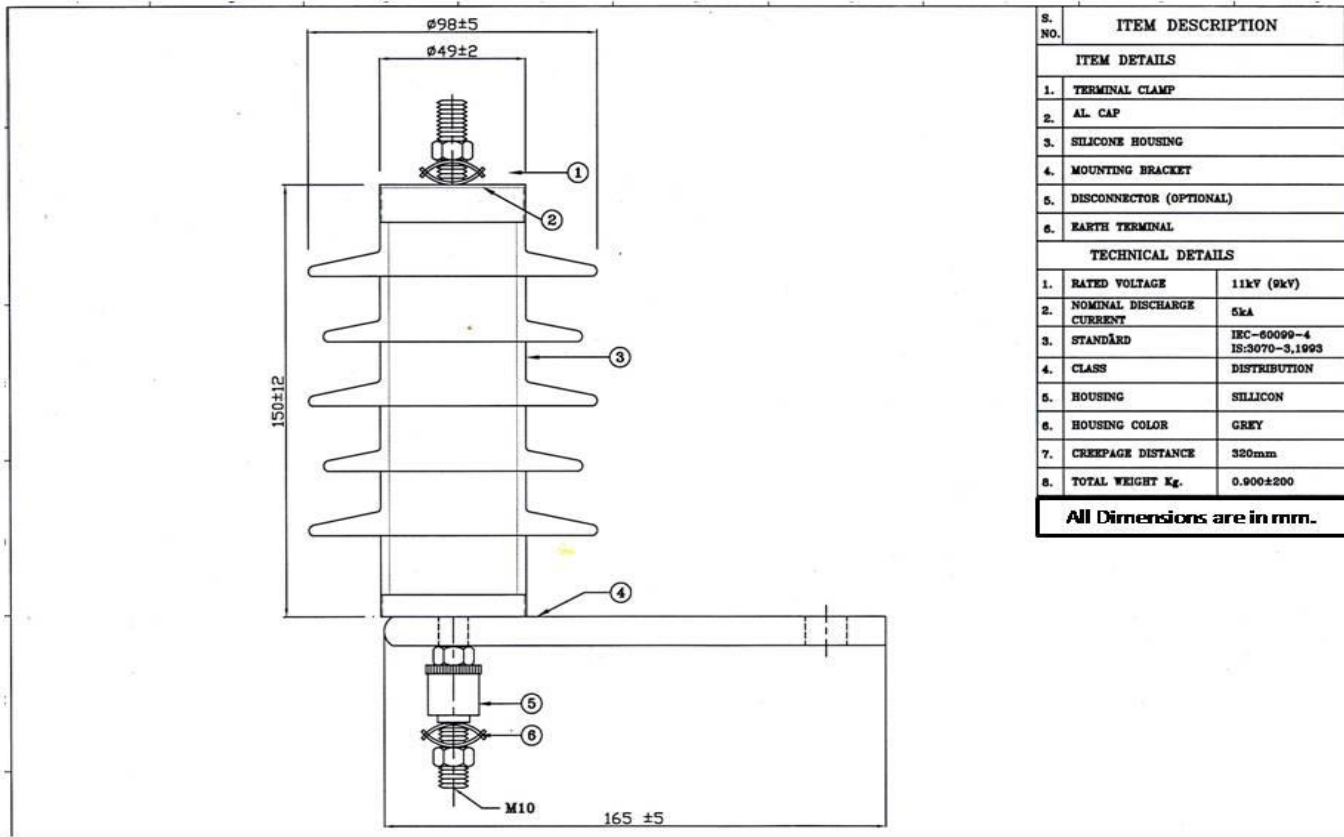

**GUARANTEED TECHNICAL PARTICULARS OF GAPLESS 9KV AND 30KV POLYMER LIGHTNING ARRESTORS**

Sl No.	Particular	9 KV LA	30 KV
1	Name of manufacturer & place of manufacture		
2	Type		
3	Model		
4	Applicable standard		
5	No. of units		
6	Rated voltage (KV rms)		
7	Rated frequency (Hz)		
8	Maximum continuous operating voltage (KV rms)		
9	Maximum leakage current at continuous operating voltage (micro amps)		
10	Temporary power frequency over voltage capacity (KV rms)		
	a) For 0.1 sec.		
	b) For 1 sec.		
	c) For 10 secs.		





	d) For 100 secs.		
11	Nominal discharge current (KA)(8/20 micro sec wave)		
12	Energy class		
13	Minimum discharge capability (KJ/KV)		
	a) For single impulse energy		
	b) For 2 consecutive discharge with 50/60 sec between them		
14	Maximum Switching Surge protection level at 500A		
15	Maximum equivalent front of wave protection level (KVp)		
16	Maximum residual voltage at nominal discharge current of 8/20 micro sec wave (KVP)		
	a) 5 KA		
	b) 10 KA		
	c) 20 KA		
17	Maximum steep current Impulse residual voltage at nominal discharge current(KVP)		
18	Maximum switching impulse Residual voltage at 500 Amp. Peak		
19	Minimum prospective symmetrical current (KA)		
20	Impulse high current short duration discharge of 4/10 Micro sec wave (KAP).		
21	Long duration current impulse withstand :		
	a) Current peak (Amps.)		
	b) Virtual duration (Micro sec.)		
22	Maximum radio interference voltage at 100 KHz (micro volts/DB)		
23	Protective ratio		
24	Total creep age distance		
25	Impulse withstand voltage		
26	Reference current (MAP)		
27	Partial discharge i.e. PICO		
28	Power frequency withstand voltage of arrester Housing		
29	(KVrms)		
	a) Dry		
	b) Wet		
	Lightning impulse withstand voltage of arrester housing (KVP)		
30	Current impulse withstand level		
31	Type of dis-connective device		
32	Dimensions of Arrester :		
33	a) Max. dia of Polymer (mm)		
	b) Complete height of arrester (mm (from base to line side		
	c) Total creepage of distance of arrester housing (mm)		
	d) Net weight of each arrester (Kg)		
34	Construction of arrester		
	a) Material of valve		
	b) Details of sealing		
	c) Description of pressure relief system		
	d) No. of unit per arrester		
	Type & Dimensions of clamping bracket		
35	Material of Top & Bottom metal cap		
36	Type of terminal arrangement (Whether as per tender		



	Specification)		
37	Size of line/ground terminals		
38	Minimum recommended spacing between Centre to centre of LA.		
39	Clearance required from ground equipment at various heights of arrester units.		
40	Earthing arrangement provided for earthing side of arrester (whether as per our requirement)		

PLACE:

DATE

SIGNATURE OF TENDERER  
NAME IN FULL  
DESIGNATION/  
STATUS IN THE FIRM  
COMPANY SEAL



## L. TECHNICAL SPECIFICATION OF 11 KV & 33 KV POLYMER PIN INSULATORS FOR OVERHEAD LINE.

1. **Scope :** This specification cover the design, manufacturing, testing at manufacturers works, transport to site, insurance, unloading & storage of 11 KV & 33 KV Polymer Pin Insulator suitable for use in 11 KV & 33 KV Overhead Lines under present scope of work..
2. **General Requirements:**
  - 2.1 The Composite insulators will be used on lines on which the conductor will be ACSR of size up to 200 Sq.mm. The insulators should withstand the conductor tension, the reversible wind load as well as the high frequency vibrations due to wind.
  - 2.2 Insulator shall be suitable for 3 Phase, 50 Hz effectively earthed 11KV Overhead Lines and 33 KV Impedance Grounded distribution systems in a moderately/heavily polluted atmosphere.
  - 2.3 Bidder must be an indigenous manufacturer and supplier of composite insulators of rating 11KV or above or must have developed proven in house technology and manufacturing process for composite insulators of above rating. The Bidder shall furnish necessary evidence in support of the above along with the bid, which can be in the form of certification from the utilities concerned, or any other documents to the satisfaction of the owner.
  - 2.4 Insulator shall be suitable for the long Rod Type.
  - 2.5 Insulators shall have sheds with good self-cleaning properties. Insulator shed profile, spacing, projection etc. and selection in respect of polluted conditions shall be generally in accordance with the commendation of IEC- 60815/ IS: 13134.
  - 2.6 The tolerances on all dimensions e.g. diameter, length and creepage distance shall be allowed as follows in line with-IEC 61109:  
 $\pm (0.04d + 1.5)$  mm when  $d \leq 300$  mm  
 $\pm (0.025d+6)$  mm when  $d > 300$  mm  
Where, d being the dimensions in millimeters for diameter, length or creepage distance as the case may be. However, no negative tolerance shall be applicable to creepage distance.
  - 2.7 The composite insulators including the end fitting connection shall be standard design suitable for use with the hardware fittings of any make conforming to relevant IEC/IS standards.
  - 2.8 All surfaces shall be clean, smooth, without cuts, abrasions or projections. No part shall be subjected to excessive localized pressure. The insulator and metal parts shall be so designed and manufactured that it shall avoid local corona formation and not generate any radio interference beyond specified limit under the operating conditions.
3. **Service condition :** The insulators to be supplied against this specification shall be suitable for satisfactory continuous operation under the following topical condition :
  - a ) Max. ambient temperature : 50 ° C
  - b ) Min. ambient temperature : -5 ° C



- c ) Relative humidity : 10 % to 100 %
- d ) Avarage number of rainy days : 100 / annum.
- e ) Max. Anual Rainfall : 1500 mm
- f ) Max. Wind Pressure : 150 Kg/ sq. Meter
- g ) Max. Wind Velocity : 50 Km/ hour
- h ) Max. Altitude above MSL : 1000 Meter.
- i ) Seismic level : 0.3 g ( Horizontal acceleration )
- j ) Avarage Thunder storm : 45 Days per annum.
- k ) Climatic condition : Moderately hot and humid tropical Climate, conductive to rust and fungus groth. Pollution level is high.

**4. System Parameters:**

- a ) Nominal system voltage : 11 KV & 33 KV.
- b ) Highest system voltage : 12 KV & 36 KV.
- c ) Power frequency : 50 Hz.
- d ) Number of Phases : Three.
- e ) System earthing : 11 KV Solidly earthed, 33 KV Impedence earth.

- 5. Standard :** The following Indian / International Standards with latest revisions and amendments shall be referred while accessing conformity of insulators with this specification.

Sl. No.	Indian Standard	Title	International Standard
1.		Definition, test methods and acceptance criteria for composite insulators for a.c. overhead lines above 1000V	IEC : 61109
2.	IS : 731	Porcelain insulators for overhead power lines with a nominal voltage greater than 1000V	IEC : 60383
3.	IS : 2071	Methods of High Voltage Testing	IEC : 60060-1
4.	IS : 2486	Specification for insulator fittings for overhead power lines with a nominal voltage greater than 1000V General Requirements and Tests Dimensional Requirements Locking Devices	IEC : 60120 IEC : 60372
5.		Thermal Mechanical Performance test and mechanical performance test on string insulator units	IEC : 60575
6.	IS : 13134	Guide for the selection of insulators in respect of polluted conditions	IEC : 60815
7.		Characteristics of string insulator units of the long rod type	IEC : 60433
8.		Hydrophobicity classification guide	STRI guide 1.92/1
9.		Radio interference characteristics of overhead power lines and high-voltage equipment	CISPR:18-2 part2
10.	IS : 8263	Methods of RI Test of HV Insulators	IEC : 60437
11.		Standard for insulators – Composite-Distribution Dead-end type	ANSI C29 13-2000
12.	IS : 4759	Hot dip zinc coatings on structural steel & other allied products	ISO : 1459 ISO : 1461
13.	IS : 2629	Recommended Practice for Hot, Dip Galvanization for iron and steel	ISO-1461 (E)



14.	IS : 6745	Determination of weight of zinc coating on zinc coated iron and steel articles	ISO : 1460
15.	IS : 3203	Methods of testing of local thickness of electroplated coatings	ISO : 2178
16.	IS : 2633	Testing of Uniformity of coating of zinc coated articles	
17.		Standard specification for glass fiber strands	ASTMD 578-05
18.		Standard test method for compositional analysis by Thermo-gravimetric	ASTM E 1131-03
19.	IS : 4699	Specification for refined secondary zinc	

## 6. Technical Requirement:

- I. Composite Insulators shall be designed to meet the light quality, safety and reliability and are capable of withstanding a wide range of environmental conditions.

Core : The internal insulating part

Housing : The external insulating part.

Metal end fittings: For attaching to hardware to support conductor.

- a) **Core:** It shall be a glass-fibber reinforced epoxy resin rod of high strength (FRP rod). Glass fibbers and resin shall be optimized in the FRP rod. Glass fibbers shall be Boron free electrically corrosion resistant (ECR) glass fibber or Boron free E-Glass and shall exhibit both high electrical integrity and high resistance to acid corrosion. The matrix of the FRP rod shall be Hydrolysis resistant. The FRP shall be manufactured through Pultrusion process. The FRP rod shall be void free.

b) **Housing (Sheath):**

The FRP rod shall be covered by a seamless sheath of a silicone elastometric compound or silicone alloy compound of a thickness of 3 mm minimum. It shall be one-piece housing using injection Moulding Principle to cover the core. The elastomer housing shall be designed to provide the necessary creepage distance and protection against environmental influences, external pollution and humidity. Housing shall conform to the requirement of IEC 61109/92-93 with latest amendments.

It shall be extruded or directly moulded on core and shall have chemical bonding with the FRP rod. The strength of the bond shall be greater than the tearing strength of the polymer. Sheath material in the bulk as well as in the sealing / bonding area shall be free from voids.

Manufacturer should furnish a description of its quality assurance programme including fabrication; testing and inspection for any material (i.e rubber) Components (i.e rod) or hardware (i.e. end filings). The manufacturer has had fabricated by others should also be included. Manufacturing methods and material composition documentation will be a part of Technical Bid to be submitted along with offer.

c) **WEATHERSHEDS:**

The composite polymer Weathersheds made of silicone elastometric compound or silicon alloy shall be firmly bonded to the sheath, vulcanized to the sheath or moulded as part of the sheath and shall be free from imperfections. The weathersheds should have silicon content of minimum 30% by weight. The strength of the weathershed to sheath interface shall be greater than the tearing strength of the polymer. The interface, if any, between sheds and sheath (housing) shall be free from voids.

d) **METAL END FITTINGS:**



End fittings transmit the mechanical load to the core. Hardware of respective specified mechanical load and shall be hot dip galvanized in Zinc coated with minimum 99.95 % purity of electrolytic high grade Zinc in accordance with IS 2629. The material used in fittings shall be corrosion resistant.

Metal end fittings shall be uniform and without sharp edges or corners and shall be free of cracks, flakes, silvers, slag, blow-holes shrinkages defects and localized porosity.

They shall be connected to the rod by means of a controlled compression technique. As the main duty of the end fittings is the transfer of mechanical loads to the core the fittings should be property attached to the core by a coaxial or hexagonal compression process and should not damage the individual fibers or crack the core.

The gap between fittings and sheath shall be sealed by flexible silicone elastomeric compound or silicone alloy compound sealant, system of attached of endfitting to the rod shall provide superior sealing performance between housing, i.e. seamless sheath and metal connection. The sealing must be moisture proof.

The dimensions of end fittings of insulators shall be in accordance with the standard dimensions stated in IEC: 60120/IS:2486 Part-II/1989.

Nominal dimensions of the pin insulator shall be in accordance with the Specific Technical Particulars. No joints in pin will be allowed. Outer portion of Pin should be Zinc coated with minimum 99.95% purity of electrolytic high grade Zinc.

The finished surface shall be smooth and shall have a good performance. The surface shall not crack or get chipped due to ageing effect under normal and abnormal service conditions or while handling during transit or erection.

The design of the fittings and the insulators shall be such that there is no local corona formation or discharges likely to cause the interference to either should or vision transmission.

Bottom end metal fitting (Shank) of Pin Insulator should be as per IS: 2486. Length of thread on shank should be minimum 110 mm for 11 KV Pin and 130 mm for 33 KV Pin insulator. Shank diameter is 20 mm for 11 KV Pin Insulator & 24 mm for 33 KV Pin Insulator. Minimum Collar diameter should be 40 mm and its minimum thickness should be of 5 mm. Two number nuts as per IS 1363 (P-III) and 4 mm thick Spring Washer shall be as per IS 3063 with latest amendments if any, Nuts and spring washer shall be hot dip galvanized.

## II. Workmanship :

### III.

- a) All the materials shall be of latest design and conform to the best engineering practices adopted in the high voltage field. Bidders shall offer only such insulators as are guaranteed by them to be satisfactory and suitable for continued good service in power transmission lines.
- b) The design, manufacturing process and material control at various stages shall be such as to give maximum working load, highest mobility, best resistance to corrosion, good finish and elimination of sharp edges and corners.
- c) The design of the insulators shall be such that stresses due to expansion and contraction in any part of the insulator shall not lead to deterioration.
- d) The core shall be sound and free of cracks and voids that may adversely affect the insulators.
- e) Weather sheds shall be uniform in quality. They shall be clean, sound and smooth and shall be free from defects and excessive flashing at parting lines.
- f) End fittings shall be free from cracks, seams, shrinks, air holes and rough edges. End fittings should be effectively sealed to prevent moisture ingress. Effectiveness of sealing system must be supported by test documents. All surfaces of the metal parts shall be





perfectly smooth without projecting points or irregularities, which may cause corona. All load bearing surfaces shall be smooth and uniform so as to distribute the loading stresses uniformly.

- g) All ferrous parts shall be hot dip galvanized to give a minimum average coating of zinc equivalent to 610 gm/sq.m. or 87 $\mu$ m thickness and shall be in accordance with the requirement of IS:4579. The zinc used for galvanizing shall be of purity 99.5% as per IS : 4699. The zinc coating shall be uniform, adherent, smooth, reasonably bright continuous and free from imperfections such as flux, ash rust stains, bulky white deposits and blisters. The galvanized metal parts shall be guaranteed to withstand at least four successive dips each lasting for one (1) minute duration under the standard preece test. The galvanizing shall be carried out only after any machining.

7. **Drawing:-** The bidder shall furnish along with the bid the outline drawing of each insulator unit including a cross sectional view of the long rod insulator unit. The drawing shall include but not be limited to the following information :

- (a) Long rod diameter with manufacturing tolerances
- (b) Minimum Creepage distance with positive tolerance
- (c) Protected creepage distance
- (d) Eccentricity of the long rod unit
  - (i) Axial run out
  - (ii) Radial run out
- (e) Unit mechanical and electrical characteristics
- (f) Weight of composite long rod units.
- (g) Identification mark
- (h) Manufacturer's catalogue number

8. **Marking:** Each insulator shall be legibly and indelibly marked (embossing/engraved) to show the following:

- a ) Name & Trade mark of the manufacturer
- b ) Month & Year of manufacturing
- c ) Voltage & Type
- d ) Minimum Failing Load ( in KN)

**“N.B. Marking with sticker/written by Ink is not acceptable.**

9. **Type Test:** The following Type Test shall have to be conducted on insulator unit, components, materials or complete strings;

- a ) Dry Positive & Negative Lightning Impulse voltage withstand test
- b ) Dry Positive & Negative Lightning Impulse Flashover voltage test
- c ) Dry & Wet Power Frequency Voltage withstand test
- d ) Dry & Wet Power Frequency Voltage Flashover test
- e ) Mechanical Failing Load test.
- f ) Radio Interference test
- g ) Recovery of Hydrophobicity test
- h ) Dye Penetration Test.
- i ) Water Diffusion Test
- j ) Chemical composition test for Silicon content
- k ) Brittle fracture resistance test.

**NB:-Notarized copy of complete type test certificate issued by any NABL accredited laboratory for the polymeric insulators shall be uploaded with part-I**



**bid, in support of evidence of compliance of the specifications & guaranteed particulars.**

**10. Routine Test :**

- a ) Identification of marking
- b ) Visual inspection
- c ) Mechanical routine test

**11. Acceptance Test :** The following test will be carried out at manufacturers works during inspection of the offered insulators before delivery :

- a ) Visual examination
- b ) Verification of dimension
- c ) Galvanizing test
- d ) Mechanical performance test
- e ) Mechanical Failing Load test

**12. Testing Facilities :**

The tenderer must clearly indicate what testing facilities are available in the works of the manufacturer and whether facilities are adequate to carry out all Routine & Acceptance Tests. These facilities should be available to TSECL's Engineers if deputed or carry out or witness the tests in the manufacturer works. If any test cannot be carried out at the manufacturer's work, the reasons should be clearly stated in the tender. The insulators shall be tested in accordance with the procedure detailed in IEC 61109/92-93 with latest amendments.

**13. Inspection :**

All Acceptance tests shall be carried out at manufacturer's works in presence of the TSECL's and manufacturers representatives. In addition to above, all routine tests are also to be carried on the insulator as per relevant IS / IEC. The entire cost of acceptance and routine test that to be carried out as per relevant IS / IEC shall be treated as included in the quoted price of Insulator. The manufacturer shall give at least 21(twenty one) days advance notice intimating the actual date of inspection and details of all tests that are to be carried out from the date when the tests will be carried out. Routine tests on all insulators shall be carried out as per IEC / IS and test reports shall be submitted along with respective inspection offer to TSECL.

**14. Sampling & Rejection during inspection:**

The sampling and rejection procedure for Acceptance Test shall be as per IEC 61109.

**15. Packing :**

a ) All insulators shall be packed in strong corrugated box of min. 7 ply duly palette or wooden crates. The gross weight of the crates along with the material shall not normally exceed 100 Kg to avoid handling problem. The crates shall be suitable for outdoor storage under wet climate during rainy season.

b ) The packing shall be of sufficient strength to withstand rough handling during transit, storage at site and subsequent handling in the field.

c ) Suitable cushioning, protective padding or dunn age or spacers shall be provided to prevent damage or deformation during transit and handling.



d) Each wooden case / crate / corrugated box shall have all the markings stenciled on it in indelible ink.

e) The bidder shall provide instructions regarding handling and storage precautions to be taken at site.

**16. Guarantee :**

In the event of any defect in the equipment / materials arising out of faulty design, materials, workmanship within a period of 12 (twelve) months of commissioning or 18 (eighteen) months from the date of last despatch of any integral part of the equipment / materials whichever is earlier the supplier shall guarantee to replace or repair the same to the satisfaction of the purchaser.

If the supplier fail to do so within a reasonable time, TSECL reserves the right to effect repair or replacement by any other agency and recover charges for repair or replacement from the supplier.

**17. Quality Assurance Plan:**

- a) The successful bidder shall submit following information along with the bid.
- b) Test certificates of the raw materials and bought out accessories.
- c) Statement giving list of important raw material, their grades along with names of sub-suppliers for raw materials, list of standards according to which the raw materials are tested. List of tests normally carried out on raw materials in presence of bidder's representative.
- d) List of manufacturing facilities available.
- e) Level of automation achieved and lists of areas where manual processing exists.
- f) List of areas in manufacturing process, where stage inspections are normally carried out for quality control and details of such tests and inspections.
- g) List of testing equipments available with the bidder for final testing equipment along with valid calibration reports.
- h) The manufacturer shall submit Manufacturing Quality Assurance Plan (QAP) for approval & the same shall be followed during manufacture and testing.
- i) The successful bidder shall submit the routine test certificates of bought out raw materials/accessories and central excise passes for raw material at the time of inspection.
- j) The Owner's representative shall at all times be entitled to have access to the works and all places of manufacture, where insulator, and its component parts shall be manufactured and the representatives shall have full facilities for unrestricted inspection of the Supplier's and sub-Supplier's works, raw materials, manufacture of the material and for conducting necessary test as detailed herein.
- k) The material for final inspection shall be offered by the Supplier only under packed condition. The owner shall select samples at random from the packed lot for carrying out acceptance tests. The lot offered for inspection shall be homogeneous and shall contain insulators manufactured in 3-4 consecutive weeks.
- l) The Supplier shall keep the Owner informed in advance of the time of starting and the progress of manufacture of material i/n their various stages so that arrangements could be made for inspection.
- m) No material shall be dispatched from its point of manufacture before it has been satisfactorily inspected and tested unless the owner in writing waives off the inspection. In the later case also the material shall be dispatched only after satisfactory testing specified herein has been completed.



- n) The acceptance of any quantity of material shall in no way relieve the Supplier of his responsibility for meeting all the requirements of the specification and shall not prevent subsequent rejection, if such materials are later found to be defective.

### ANNEXURE: A

#### **Test on Insulator units**

- a. RIV Test (Dry): The insulator string along with complete hardware fittings shall have a radio interference voltage level below 100 micro volts at one MHz when subjected to 50 Hz voltage of 10 kV & 30 kV for 11 kV & 33 kV class insulators respectively under dry condition. The test procedure shall be in accordance with IS: 8263/IEC: 437/CISPR 18-2.
- b. Brittle Fracture Resistance Test: Brittle fracture test shall be carried out on naked rod along with end fittings by applying “1n HNO<sub>3</sub> acid” (63 g conc. HNO<sub>3</sub> added to 937 g water) to the rod. The rod should be held at 80% of SML for the duration of the test. The rod should not fail within the 96 Hour test duration. Test arrangement should ensure continuous wetting of the rod with Nitric acid.
- c. Recovery of Hydrophobicity & Corona Test:
- The surface of selected samples shall be cleaned with isopropyl alcohol. Allow the surface to dry and spray with water. Record the Hydrophobicity classification in line with STRI guide for Hydrophobicity classification (Extract enclosed at Annexure-D) Dry the sample surface.
  - The sample shall be subjected to mechanical stress by bending the Sample over a ground electrode. Corona is continuously generated by applying 12 kV to a needle like electrode placed 1 mm above the sample surface. Tentative arrangement shall be as shown in Annexure-E. The test shall be done for 100 hrs.
  - Immediately after the corona treatment, spray the surface with Water and record the HC classification. Dry the surface and repeat the corona treatment as at Clause-2 above. Note HC classification. Repeat the cycle for 1000 Hrs. or until an HC of 6 or 7 is obtained. Dry the sample surface.
  - Allow the sample to recover and repeat hydrophobicity Measurement at several time intervals. Silicone rubber should recover to HC 1 – HC 2 within 24 to 48 hours, depending on the Material and the intensity of the corona treatment.
- d. Chemical composition test for Silicon content:  
The content of silicon in the composite polymer shall be evaluated by EDX (Energy Dispersion X-ray) Analysis or Thermo-gravimetric analysis. The test may be carried out at CPRI or any other NABL accredited laboratory.

### 18. MANDATORY PARTICULARS FOR 11 KV & 33 KV PIN INSULATOR

	11 KV Pin	33 KV Pin
Type of insulator	Polymeric composite Pin Insulator	Polymeric composite Pin Insulator
Reference Standard	IEC 61109	IEC 61109
Material of FRP Rod	Borron free ECR	Borron free ECR
Material of sheds	Silicon Rubber	Silicon Rubber



Material of Top End Fittings	SGCI /MCI/FORGED STEEL	SGCI /MCI/ FORGED STEEL
Material of Bottom End Fittings	FORGED STEEL	FORGED STEEL
Material of sealing compound	RTV Silicon	RTV Silicon
Colour of sheds	Grey	Grey
Rated voltage	11 KV	33 KV
Highest voltage	12 KV	36 KV
Dry Power Frequency Withstand voltage	60 KV	95 KV
Wet Power Frequency Withstand voltage	35 KV	75 KV
Dry Power Frequency Flashover Voltage	75 KV	130 KV
Wet Power Frequency Flashover Voltage	45 KV	90 KV
Dry Lightning Impulse withstand voltage	Positive : 75 KV Negative : 80 KV	Positive : 170 KV Negative : 180 KV
Dry Lightning Impulse Flashover voltage	Positive : 95 KV Negative : 100 KV	Positive : 210 KV Negative : 230 KV
RIV at 1 MHz when energised at 10 KV / 30 KV (rms) under dry condition	< 50 microvolt	< 70 microvolt
Creepage distance ( min )	320 mm	900 mm
Min Failing load	5 KN	10 KN
Dia of FRP Rod	20 mm	24 mm
Length of FRP Rod (min)	165 mm	300 mm
Dia of weather sheds	100 mm	110 mm
Thickness of housing	3 mm	3 mm
Dry arc distance	150 mm	300 mm
Method of fixing sheds to housing	Injection moulding	Injection moulding
Visible Discharge Voltage (PF)	9 KV	27 KV
No of weather sheds (min)	Three	Eight
Type of sheds	Aerodynamic	Aerodynamic
Dia of bottom end fitting	20 mm	24 mm
Thread length of bottom end fitting	110 mm (Min)	130 mm (min)
Type of packing	Wooden / Corrugated box	Wooden / Corrugated box
No of insulator in each pack	Thirty	Twenty
Guarantee	12 months from commissioning or 18 months from the date of last despatch.	12 months from commissioning or 18 months from the date of last despatch.

**ANNEXURE B**

**19. G T P TO BE FILLED UP BY THE BIDDER**

**Name of the manufacturer:**



**Address of works:**

<b>Sl no</b>	<b>Particulars</b>	<b>11 KV Pin</b>	<b>33 KV Pin</b>
1	Type of insulator		
2	Reference Standard		
3	Material of FRP Rod		
4	Material of sheds		
5	Material of Top End Fittings		
6	Material of Bottom End Fittings		
7	Material of sealing compound		
8	Colour of sheds		
9	Rated voltage		
10	Highest voltage		
11	Dry Power Frequency Withstand voltage		
12	Wet Power Frequency Withstand voltage		
13	Dry PF Flashover Voltage		
14	Wet PF Flashover Voltage		
15	Dry Lightning Impulse withstand voltage		
16	Positive		
17	Negative		
18	Dry Lightning Impulse Flashover voltage		
19	Positive		
20	Negative		
21	RIV at 1 MHz when energised at 10 KV / 30 KV (rms) under dry condition		
22	Creepage distance ( min )		
23	Visible Discharge Voltage (PF)		
24	Minimum Failing load		
25	Dia of FRP Rod		
26	Length of FRP Rod		
27	Dia of weather sheds		
28	Thickness of housing		
29	Dry arc distance		
30	Method of fixing sheds to housing		
31	No of weather sheds		
32	Type of sheds		
33	Dia of bottom end fitting		
34	Thread length of bottom end fitting		
35	Weight of composite insulator		
36	Type of packing		
37	No of insulator in each pack		
38	Weight of Insulator		
39	Gross weight of package		
40	Marking		
41	Guarantee		





## M. TECHNICAL SPECIFICATION FOR FITTING FOR DISC INSULATORS OF BALL & SOCKET TYPE.(3 NOS U BOLT TYPE)

1.0 **General**:-The fittings shall consist of the following components:

- a) Cross arm strap conforming to IS:2486 (Pt.II)-1989.
- b) Forged steel ball eye for attaching the socket end of the strain insulator to the cross arm strap. Forgings shall be made of steel as per IS:2004-1978.
- c) Aluminium alloy thimble-socket made out of permanent mould cast, high strength aluminium alloy for attaching to the strain insulator on one end and for accommodating the loop of the helically formed dead-end fittings at the other end in its smooth internal contour. The thimble-socket shall be attached to the strain insulator with the help of locking pin as per the dimensions given in IS:2486 (Pt.II)-1989 and
- d) Helically formed dead-end grip having a pre-fabricated loop to fit into the grooved contour of the thimble on one end and for application over the conductor at the other end. The formed fitting shall conform to the requirement of IS:12048-1987.
- e) Nominal dimensions of the Ball & Socket type insulator fittings are shown in Fig. 1 & 2

2.0 **SPECIFICATION FOR 11KV SINGLE INSULATOR TENSION FITTINGS AS PER IS: 2486(P-I)/1971 & 2486/(P-II)/1974 AND (P-III)/1974 OR LATEST AMENDMENTS.**

Type of Fittings: - insulator tension fittings 3 'U' Bolt Type.

### TECHNICAL SPECIFICATION FOR THE MAIN PARTS OF SINGLE INSULATOR TENSION FITTINGS SUITABLE FOR DOG CONDUCTOR OF SIZE 6/7/4.72/1.57 mm

SL No	Description	Materials	Guiding drawing/specification	Remarks
1	2	3	4	5
1.	Tension End Fittings:			
a).	Cross-arm Straps	Mild Steel Galvanized	As per Drawing i.e.Fig.1	A=100mm,B=16mm,C=140mm, D=35mm,E=6mm, H=145mm.
b).	Ball and connector (Ball Eye/ Clevis)	Forged Steel Galvanized	As per Drawing i.e.Fig.1	Shank dia. Of ball-16 mm of matching socket of 45 KN Insulator.Wt. not less than 200gms.
2.	Tension Clamp adopter (Socket Eye)	Forged Steel Galvanized	As per Drawing i.e.Fig.1 As in 1(b).	To match ball of 45 KN Disc Insulator.Wt. not less than 450gms.(600)



3.	Conductor Tension Clamp:			
a).	Male Part (Sleeve)	Aluminium Alloy	As per Drawing i.e. Fig.1	To match 3(b).Wt.not less than 65gms. (75-80)
b).	Female part	Aluminium Alloy	As per Drawing i.e.Fig.1	To match 3(a). Wt. in between 480-490 gms. excluding 'U' bolts, nuts & washers.
c).	'U' Bolts & Nuts	Mild Steel Galvanization	As per Drawing i.e.Fig.1	Dia.-9.5mm,over all length 160-165 mm.
4.	Spring Washer	Mild Steel Galvanization for both item-4, 5	As per Drawing i.e.Fig.1	2mm thick. (1) External dia. not less than 25mm=1No. (2) External dia. not less than 15mm.= 6nos
5.	Flat washer	Mild Steel for both item-4 & 5	As per Drawing i.e.Fig.1	i).2mm thick to suit 16mm dia bolt, external dia. not less than 35mm = 2nos. ii).2.5mm thick to suit 16mm dia bolt, external dia. not less than 20mm = 6nos.
6.	Split Pins	Mild Steel	As per Drawing i.e.Fig.1	To suit 4mm dia holes in 16mm dia bolts = 3 nos.
7.	'W' Clip	Phosphor	As pr Drawing	

Fig. 1 SINGLE INSULATOR TENSION FITTING

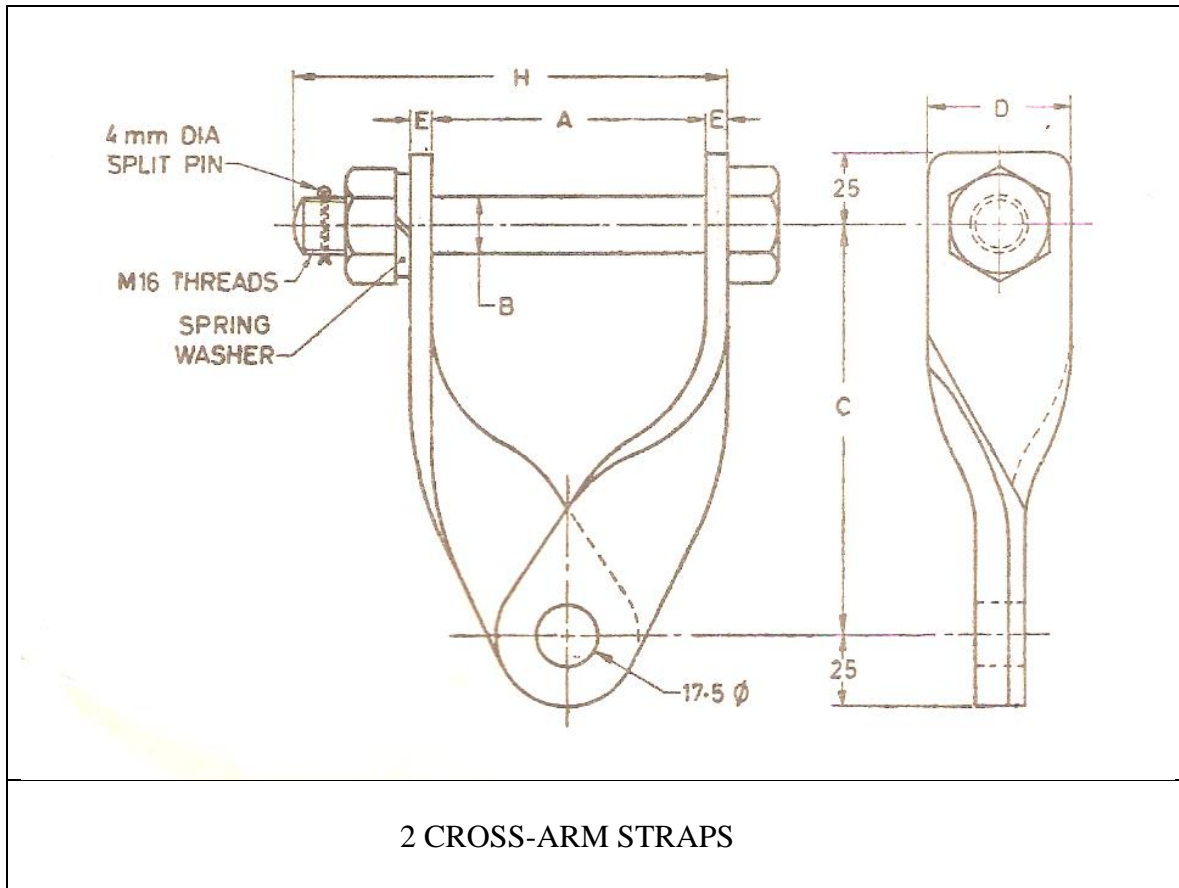

Note s:-  
(i) All dimensions are in mm but not to scale.  
(ii) Galvanization to conform to IS: 2633/

1964 or latest version

(iii) All other dimensions are as per drawing.

3.0 SERVICE CONDITIONS:-The 11KV single insulator tension fittings to be supplied against this Specification shall be suitable for satisfactory continuous operation under the following climatic conditions as per IS: : 2486(P-I)/1971 & 2486/(P-II)/1974 and (P-III)/1974 or latest revision.

i. Location:	At various locations in Tripura.
ii. Max. ambient air temperature (Deg0 C):	45
iii. Min. ambient air temperature (Deg0 C):	4
iv. Max yearly daily ambient air temperature (Deg0 C):	40
v. Max average weighed average ambient temperature (Deg0 C):	32
vi. Max. Altitude above mean sea level(Meters):	1000 M.



#### 4.0 TEST AND INSPECTION

4.1 Tests:- The helically formed fittings for strain insulators shall be subjected to tests as per IS:12048-1987. The other hardware fittings shall be tested as per IS:2486 (Part-I). Following tests on clamps, insulator string fittings and non-tension components shall be carried out at the works of the manufacturer as per relevant ISS before delivery of each lot in presence of the representative of purchaser

SL No.	Description	Materials	Quantity
1.	Cross Arm Straps	Mild Steel Galvanized	1 Pair
2.	Ball and connector (Ball Eye/ Clevis)	Forged Steel Galvanized	1No.
3.	Tension Clamp adopter (Socket Eye)	Forged Steel Galvanized	1No.
4.	Tension Clamp (a) Male Part (b) Female Part	Aluminium Alloy (Diacasted) Aluminium Alloy (Diacasted)	1No. 1No.
5.	Rivet/Cotter Bolt	Forged Steel Galvanized	2Nos.
6.	Bolt, Nut	Mild Steel Galvanized	1No.
7.	Split pin	Mild Steel Galvanized	3 Nos.
8.	'W' Clip	Phosphor Bronze	1No.
9.	'U' Bolts & Nuts	Mild Steel (Electro Galvanized)	3 Nos.
10.	Spring Washer	Mild Steel Galvanized	7 Nos.
11.	Flat Washer	Mild Steel Galvanized	8 Nos.
SL No.	Description	Materials	Quantity
1.	Cross Arm Straps	Mild Steel Galvanized	1 Pair
2.	Ball and connector (Ball Eye/ Clevis)	Forged Steel Galvanized	1No.
3.	Tension Clamp adopter (Socket Eye)	Forged Steel Galvanized	1No.
4.	Tension Clamp (a) Male Part (b) Female Part	Aluminium Alloy (Diacasted) Aluminium Alloy (Diacasted)	1No. 1No.
5.	Rivet/Cotter Bolt	Forged Steel Galvanized	2Nos.
6.	Bolt, Nut	Mild Steel Galvanized	1No.
7.	Split pin	Mild Steel Galvanized	3 Nos.
8.	'W' Clip	Phosphor Bronze	1No.
9.	'U' Bolts & Nuts	Mild Steel (Electro Galvanized)	3 Nos.
10.	Spring Washer	Mild Steel Galvanized	7 Nos.
11.	Flat Washer	Mild Steel Galvanized	8 Nos.

A. Type Tests:

- (a). Visual examination,
- (b). Verification of dimensions,



- (c). Mechanical test (for both string fittings & non-tension components),
- (d). Galvanizing/electroplating tests,
- (e). Slip strength test (for clamps only),
- (f). Electrical resistance test (for clamps only),
- (g). Ultimate strength test (for clamps only),
- (h). Heating cycle test (for clamps only),
- (i) Chemical composition test (for both string fittings & non-tension components).

**B. Acceptance Tests:**

- (a) Visual examination Test,
- (b) Verification of dimensions,
- (c) Mechanical test (except insulator string fittings),
- (d) Ultimate strength test (except non-tension components).
- (e) Galvanizing tests,
- (f) Chemical composition test,
- (g) Electrical resistance test (for clamps only).

**C. Routine Tests:**

- (a) Visual examination Test,
- (b) Mechanical test (for clamps and insulator string fittings only).

Sample at random will be selected from the offered lot for the above testing as per IS.

Note : Purchaser reserves the right to get all or any type test carried out on one sample per 1000 single insulator tension fittings at the cost of supplier from any recognized laboratory / Government test house.

4.2 The supplier shall furnish the type test / the routine test certificates as part of the condition for supply of 11KV single insulator tension fittings in bulk quantity at the discretion of the purchaser.

#### 4.3.0 INSPECTION

4.3.1 All tests and inspection shall be made at the place of manufacture unless otherwise especially agreed upon by the manufacturer and purchaser at the time of purchase. The manufacturer shall afford the inspector representing the purchaser all reasonable facilities without charge to satisfy him that the material is being furnished in accordance with specification.

4.3.2 The purchaser reserves the right to have the tests carried out at the cost of the supplier by an independent agency whenever there is dispute regarding the quality of supply.

#### 5.0 PACKING & MARKING

##### 5.1 PACKING

The 11KV single insulator tension fittings shall be so packed that the 11KV single insulator tension fittings are adequately protected against breakage and damage in ordinary handling and transit. To avoid damage of 11KV single insulator tension fittings trans-shipment in between the road transportation must be avoided i.e. each consignment should be transported from factory to **work site Storeyard..**

##### 5.2 MARKING



A. The following information shall be marked on each clamp:

- a) Manufacturers' name
- b) Manufacturers' Trade mark
- c) 'ISI certification mark if any

6.0 Guaranteed & other technical particulars for 11kv single insulator tension fittings Suitable for DOG Conductor of size 6/7/4.72/1.57 mm as per IS: 2486(P-I)/1971 & 2486/(P-II)/1974 AND (P-III)/1974 or latest amendments.

(To be furnished by the Manufacturer)

**SL.  
No**

**Description**

- 1) Name of Manufacturer:-
- 2) Place of Manufacture:-
- 3) ISI Certification Mark if any:-
- 4) Type of Fittings: -

SL No	Description	Materials	Guiding drawing/specification	Remarks
1	2	3	4	5
1.	<b><u>Tension End Fittings:</u></b>			
a).	Cross-arm Straps with Nuts & Bolts			
b).	Ball and connector			
2.	Tension Clamp			
3.	<b><u>Conductor Tension Clamp:</u></b>			
a).	Male part (Sleeve)			
b).	Female part			
c).	'U' Bolts & Nuts			
4.	Spring Washer			
5.	Flat washer			
6.	Split Pins			
7.	'W' Clip			
8.	Rivet /Cotter Bolt			
9.	Nuts & Bolts			

Signature of Authorized

Signatory of the firm  
Seal  
of the firm.





## N. TECHNICAL SPECIFICATION FOR 11KV COMPOSITE POLYMERIC DISC INSULATOR (Ball & Socket Type)

**1.0SCOPE:-**This specification covers design, manufacture, testing, inspection, packing and supply of composite insulators for use in the 11 KV overhead transmission lines. The composite **polymer insulators** shall be of following type:

1.1 **Long rod insulators ball and socket type** for AAAC/ACSR conductors in **tension application** at dead end/angle / cut point.

1.2 The Bidder should be original manufacturer of the composite insulators and shall have all the facilities to manufacturing and in house testing or their product.  
**This will be pre-qualifying requirement as a “Bidder”.**

**2.0STANDARDS :-**Following Indian/International Standards, which shall mean latest revision, with amendments / changes adopted and published, unless specifically stated otherwise in the Specification, shall be referred while accessing conformity of Insulators with these specifications.

Sr. No.	Indian Standard	Title	International Standard
1		Definition, test methods and acceptance criteria for composite Insulators for a. c. overhead lines above 1000V.	IEC:61109
2	IS: 731	Porcelain insulators for overhead power lines with a nominal voltage greater than 1000V.	IEC: 60383
3	IS:2071	Methods of High Voltage Testing.	IEC:60060-1
4	IS:2486	Specification for Insulator fittings for overhead power lines with a nominal voltage greater than 1000V General Requirements and Tests Dimensional Requirements locking devices.	IEC:60120 IEC:60372
5		Thermal Mechanical performance test and mechanical performance test on string Insulators units.	IEC:60575
6	IS: 13134	Guide for the selection of insulators in respect of polluted condition.	IEC: 60815
7		Characteristics of string insulator units of the long rod type.	IEC: 60433
8		Hydrophobicity Classification Guide.	STRI guide 1.92/1
9		Radio interference characteristics of overhead power lines and high voltage equipment.	CISPR 18.2 Part 2
10	IS:8263	Methods of RI Test of HV Insulators.	IEC:60437
11		Standard for Insulators- Composite- Distribution Dead-end Type.	ANSI C 29.13-2000



12	IS:4759	Hot dip zinc coatings on structural steel & other allied products.	ISO:1459
13	IS:2629	Recommended practice for Hot Dip galvanization for iron and steel	ISO:1461(E)
14	IS:6745	Determination of weight of zinc coating on zinc coated Iron and steel articles.	ISO:1460
15	IS:3203	Methods of testing of local thickness of electroplated coatings.	ISO:2178
16	IS:2633	Testing of Uniformity of coating of zinc coated articles.	
17		Standard specification for glass fiber standards.	ASTM D 578-05
18		Standard specification for compositional analysis by Thermogravimetry.	ASTM E 1131-03
19	IS:4699	Specification for refined secondary zinc	

**2.1** The 11KV Disc Insulator / materials shall conform in all respect to the relevant Indian/International Standard Specification, with latest amendments thereof:

**SPECIFICATION FOR 11KV COMPOSITE POLYMERIC DISC INSULATOR ( B & S TYPE) AS PER IEC:61109**

Name	Material
Socket fitting	S. G. Iron as per IS:1865
Security Clip( W Clip)	Phosphor Bronze
Housing	Polymer Silicon
FRP Rod	Fiber Reinforced Plastic
Ball fitting	S. G. Iron as per IS:1865

Sl no.	Description	Min. requirement for 11 KV 45 KN
1	Type of Insulator	Polymeric Composite
2	Standard according to which the insulators manufactured and tested.	IEC 61109:2008
3	Name of material used in manufacture of the insulator with class/grade)	SILICON Wacker-Germany Dow Corning-USA or equivalent Silicon material as per specification.
a)	Material of core(FRP rod) (i) E-glass of ECR-glass. (ii) Boom content	ECR or BORRON FREE
b)	Material of housing & weathersheds (silicon content by weight)	SILICON RUBBER 43 %



c)	Material of end fittings	SGI
d)	Sealing compound for end fittings	RTV SILICON
4	Colour	GREY
5	Electrical characteristics	
a)	Nominal system voltage	11 KV
b)	Highest system voltage	12 KV
c)	Dry Power frequency withstand	70 KV
d)	Wet Power frequency withstand	45 KV
e)	Dry flashover voltage	80 KV
f)	Wet flash over voltage	50 KV
g)	Dry lighting impulse withstand voltage a) Positive b) Negative	110 KV 110 KV
h)	Dry lighting impulse flashover voltage a) Positive b) Negative.	120 KV 130 KV
i)	RIV at 1 MHz when energized at 10 KV /30kV (rms) under dry condition.	<100 micro volts
j)	Creepage distance (Min.)	<b>320 MM</b>
6	Mechanical characteristics : Minimum failing load.	<b>45 KN</b>
7	Dimensions of insulator	
i)	Weight	1.25 KG(Approx.)
ii)	Dia of FRP rod	16 MM (Min.)
iii)	Length of FRP rod	240 MM (Min.)
iv)	Dia of weathersheds	To be submitted by bidder
v)	Thickness of housing	3 MM
vi)	Dry arc distance Dimensioned drawings of insulator (including weight with tolerances in weight) enclosed.	160+5 MM (+ve tolerance shall be allowed)
8	Method of fixing of sheds to housing specify). Single mould or Modular construction (injection moulding /compression moulding)	Injection moulding
9	No of weathersheds	3 (min.)
10	Type of sheds	
i)	Aerodynamic	Aerodynamic
ii)	With underribs	
11	Packing details	



a)	Type of packing	Strong corrugated box of minimum 7 ply duly paleted / Wooden Box
b)	No. of insulators in each pack	30 nos.(Maximum)
c)	Gross weight of package.	50 KG. (Maximum)
12	Any other particulars which the bidder may like to give.	
13	The insulators shall have “W” type phosphors Bronze or “R” type Stainless steel security clips for ball sockets portion of insulators confirming to IS-2486	YES
14	Length of Crimping dye for crimping at both end of FRP Rod should be minimum	25 MM

**N.B. The bidder must submit the design & drawing with dimensions & labeling in respect of the GTP submitted with the bid failing which tender will be treated non-responsive. Moreover, Colour Photograph of the finished product of the item must also be submitted with the technical bid.**

**a. SERVICE CONDITIONS**

The 11KV Composite Polymeric Disc Insulator to be supplied against this Specification shall be suitable for satisfactory continuous operation under the following climatic conditions as per IEC: 61109 or latest revision.

- i. Location: At various locations in Tripura.
- ii. Max. ambient air temperature (Deg<sup>0</sup> C): 50<sup>0</sup>C
- iii. Maximum relative humidity: 95% (sometime approaches Saturation point)
- iv. Max. Altitude above mean sea level(Meters): 1000 M.

**4.0 TEST AND INSPECTION**

Insulators offered shall be manufactured with the same configuration & raw materials as used in the insulators for which design & type test reports are submitted. The manufacturer shall submit a certificate for the same. The design & type test reports submitted shall not be more than five years old.

**4.1 DESIGN TESTS :**

For polymeric insulators it is essential to carry out design test as per clause 4.1 of IEC 61109 / 92-93 with latest amendments. The design tests are intended to verify the suitability of the design, materials and method of manufacture (technology). When a composite insulator is



submitted to the design tests, the result shall be considered valid for the whole class of insulators, which are represented by the one tested and having the following characteristics:

- Same materials for the core, and sheds and same manufacturing method;
- Same material of the fittings, the same design, the same method of attachment;
  - Same or greater layer thickness of the shed material over the core (including a sheath where used );
- Same or smaller ratio of the highest system voltage to insulation length;
  - Same or smaller ratio of all mechanical loads to the smallest core diameter between fittings
- Same or greater diameter of the core.

The tested composite insulators shall be identified by a drawing giving all the dimensions with the manufacturing tolerances.

Manufacturer should submit test reports for Design Tests as per IEC – 61109 (clause –5) along with the bid. Additionally following tests shall be carried out or reports for the tests shall be submitted after award of contract:

**UV test:** the test shall be carried out in line with clause 7.2 of ANSI C29.13.

#### 4.2 TYPE TESTS :

The type tests are intended to verify the main characteristics of a composite insulator. The type tests shall be applied to composite insulators, the class of which has passed the design tests.

**4.2.1** Following Type test shall be conducted on a suitable number of individual insulator units, components, materials or complete strings:

Sl no	Description of type test	Test procedure / standard
1	Dry lightning impulse withstand voltage test	As per IEC 61109(Clause 6.1)
2	Wet power frequency test	As per IEC 61109(Clause 6.2)
3	Mechanical load-time test	As per IEC 61109(Clause 6.4)
4	Radio interference test	As per IEC 61109(Clause 6.5) revised
5	Recovery of Hydrophobicity test	Annexure – B This test may be repeated every 3 yrs by the manufacturer
6	Chemical composition test for silicon content	Annexure – B Or any other test method acceptable to the owner
7	Brittle fracture resistance test	Annexure – B

The bidder shall submit type test reports as per IEC 61109 along with the bid. Additional type tests required if any shall be carried out by the manufacturer, after award of contract for which no additional charges shall be payable. In case, the tests have already been carried out, the manufacturer shall submit reports for the same.

#### 4.3 ACCEPTANCE TESTS :

The test samples after having withstood the routine test shall be subject to the following acceptance tests in order indicated below:



(a)	Verification of dimensions	Clause 7.2 IEC: 61109
(b)	Verification of the locking system (if applicable)	Clause 7.3 IEC: 61109,
©	Verification of tightness of the interface Between end fittings & Insulator housing	Clause 7.4 IEC: 61109 amendment 1 of 1995
(d)	Verification of the specified mechanical load	Clause 7.4 IEC: 61109, amendment 1 of 1995
(e)	Galvanizing test	IS:2633/IS:6745

#### 4.4 ROUTINE TESTS:

Sl no	Description	Standard
1	Identification of marking	As per IEC: 61109 Clause 8.1
2	Visual Inspection	As per IEC: 61109 Clause 8.2
3	Mechanical routine test	As per IEC: 61109 Clause 8.3

Every polymeric insulator shall withstand mechanical routine test at ambient temperature tensile load at RTL corresponding to at least 50 % of the SML for at least 10 sec.

#### 4.5 TESTS DURING MANUFACTURE:

Following tests shall also be carried out on all components as applicable

(a)	Chemical analysis of zinc used for galvanizing
(b)	Chemical analysis, mechanical, metallographic test and magnetic particle inspection for malleable castings.
©	Chemical analysis, hardness tests and magnetic particle inspection for forgings.

#### 4.6 QUALITY ASSURANCE PLAN :

**4.6.1** The successful bidder shall submit following information along with the bid:

**4.6.2** Test certificates of the raw materials and bought out accessories.

**4.6.3** Statement giving list of important raw material, their grades along with names of sub-Suppliers for raw materials, list of standards according to which the raw materials are tested. List of tests normally carried out on raw materials in presence of bidder's representative.

**4.6.4** List of manufacturing facilities available.

**4.6.5** Level of automation achieved and lists of areas where manual processing exists.

**4.6.6** List of areas in manufacturing process, where stage inspections are normally carried out for quality control and details of such tests and inspections.

**4.6.7** List of testing equipments available with the bidder for final testing of equipment along with valid calibration reports.

**4.6.8** The manufacturer shall submit Manufacturing Quality Assurance Plan (QAP) for Approval & the same shall be followed during manufacture and testing.

**4.6.9** The successful bidder shall submit the routine test certificates of bought out raw materials / accessories and central excise passes for raw material at the time of inspection.





- 4.6.10** The Owner's representative shall at all times be entitled to have access to the works and all places of manufacture, where insulator, and its component parts shall be manufactured and the representatives shall have full facilities for unrestricted inspection of the Supplier's and sub-Supplier's works, raw materials, manufacture of the material and for conducting necessary test as detailed herein.
- 4.6.11** The material for final inspection shall be offered by the Supplier only under packed condition. The owner shall select samples at random from the packed lot for carrying out acceptance tests. The lot offered for inspection shall be homogeneous and shall contain insulators manufactured in 3-4 consecutive weeks.
- 4.6.12** The Supplier shall keep the Owner informed in advance of the time of starting and the progress of manufacture of material in their various stages so that arrangements could be made for inspection.
- 4.6.13** No material shall be dispatched from its point of manufacture before it has been satisfactorily inspected and tested unless the owner in writing waives off the inspection. In the later case also the material shall be dispatched only after satisfactory testing specified herein has been completed.
- 4.6.14** The acceptance of any quantity of material shall in no way relieve the Supplier of his responsibility for meeting all the requirements of the specification and shall not prevent subsequent rejection, if such material are later found to be defective.

**4.7 RETEST AND REJECTION:**

**4.7.1** Sample Procedure for testing of insulators shall be as per clause 7.1 to 7.6 of IEC 61109 for Acceptance & Routine Tests. For the sampling tests, two samples are used, E1 and E2. The sizes of these samples are indicated in the table below.

Lot Size (N)	Sample Size	
	E1	E2
N < 300	Subject to agreement	
300 < N < 2000	4	3
2000 < N < 5000	8	4
5000 < N < 10000	12	6

If more than 10000 insulators are concerned, they shall be divided into an optimum number of lots comprising between 2000 and 10000 insulators. The results of the tests shall be evaluated separately for each lot. The insulators shall be selected by the purchaser's representative from the lot at random.

The samples shall be subjected to the applicable sampling tests.

The sampling tests are:

- Verification of dimensions - (E1 + E2)
- Verification of the locking system - (E2)
- Verification of tightness of the interface between end fittings & Insulator housing - (E2)
- Verification of the specified mechanical load SML - (E1)
- Galvanizing test - (E2)



In the event of a failure of the sample to satisfy a test, the retesting procedure shall be as follows

If only one insulator or metal part fails to comply with the sampling tests, a new sample equal to twice the quantity originally submitted to the tests shall be subjected to retesting. The retesting shall comprise the test in which failure occurs. If two or more insulator or metal parts fail to comply with any of the sampling tests or if any failure occurs during the retesting, the complete lot is considered as not complying with this standard and shall be withdrawn by the manufacturer.

Provided the cause of the failure can be clearly identified, the manufacturer may sort the lot to eliminate all the insulators with these defects. The sorted lot then be resubmitted for testing. The number then selected shall be three times the first chosen quantity for tests. If any insulators fail during this retesting, the complete lot is considered as not complying with this standard and shall be withdrawn by the manufacturer.

#### 4.7.2 Verification of dimensions (E1 + E2)

The dimensions given in the drawings shall be verified. The tolerances given in the drawing are valid. If no tolerances are given in the drawings the values mentioned in this specification shall hold good.

#### 4.7.3 Verification of the locking system (E2)

This test applies only to the insulators equipped with socket coupling as specified by IEC 120 and is performed according to IEC 383.

#### 4.7.4 Verification of tightness of the interface between end fittings & Insulator housing (E2)

One insulator selected randomly from the sample E2, shall be subjected to crack indication by dye penetration, in accordance with ISO 3452, on the housing in the zone embracing the complete length of the interface between the housing and metal fitting and including an additional area, sufficiently extended beyond the end of the metal part.

The indication shall be performed in the following way.

- the surface shall be properly pre-cleaned with the cleaner ;
- the penetrant, which shall act during 20 minutes, shall be applied on the cleaned surface;
- with in 5 minutes after the application of the penetrant, the insulator shall be subjected, at the ambient temperature, to a tensile load of 70 % of the SML, applied between the metal fittings; the tensile load shall be increased rapidly but smoothly from zero up to 70 % of the SML, and then maintained at this value for 1 minute;
- the surface shall be cleaned with the excess penetrant removed, and dried;
  
- the developer shall be applied if necessary;
- the surface shall be inspected.

Some housing materials may be penetrated by the penetrant. In such cases evidence shall be provided to validate the interpretation of the results.

After the 1 min. test at 70 % of the SML, if any cracks occur, the housing and, if necessary, the metal fittings and the core shall be cut, perpendicularly to the crack in the middle of the widest of the indicated cracks, into two halves. The surface of the two halves shall then be investigated for the depth of the cracks.



#### 4.7.5 Verification of the specified mechanical load SML

The insulators of the sample E1 shall be subjected at ambient temperature to at tensile load, applied between the couplings. The tensile load shall be increased rapidly but smoothly from zero to approximately 75 % of the SML, and then be gradually increased to the SML  
in a time between 30 sec. to 90 sec.

If 100 % of the SML is reached in less than 90 s, the load (100 % of the SML) shall be maintained for the remainder of the 90 s. (This test is considered to be equivalent to a 1 min withstand test at the SML.)

The insulators have passed the test at **4.7.4&4.7.5** above if:

- No failure (breakage or complete pull out of the core, or fracture of the metal fitting) occurs either during the 1 min. 70 % withstand test (a) or during the 1min.100 % withstand test (b).
- No cracks are indicated after the dye penetration method described in **4.7.4** above.
- The investigation of the halves described in **4.7.4** above shows clearly that the cracks do not reach the core.

#### 4.7.6 Galvanizing test

This test shall be performed according to IS: 2633/IS: 6745 on galvanized parts.

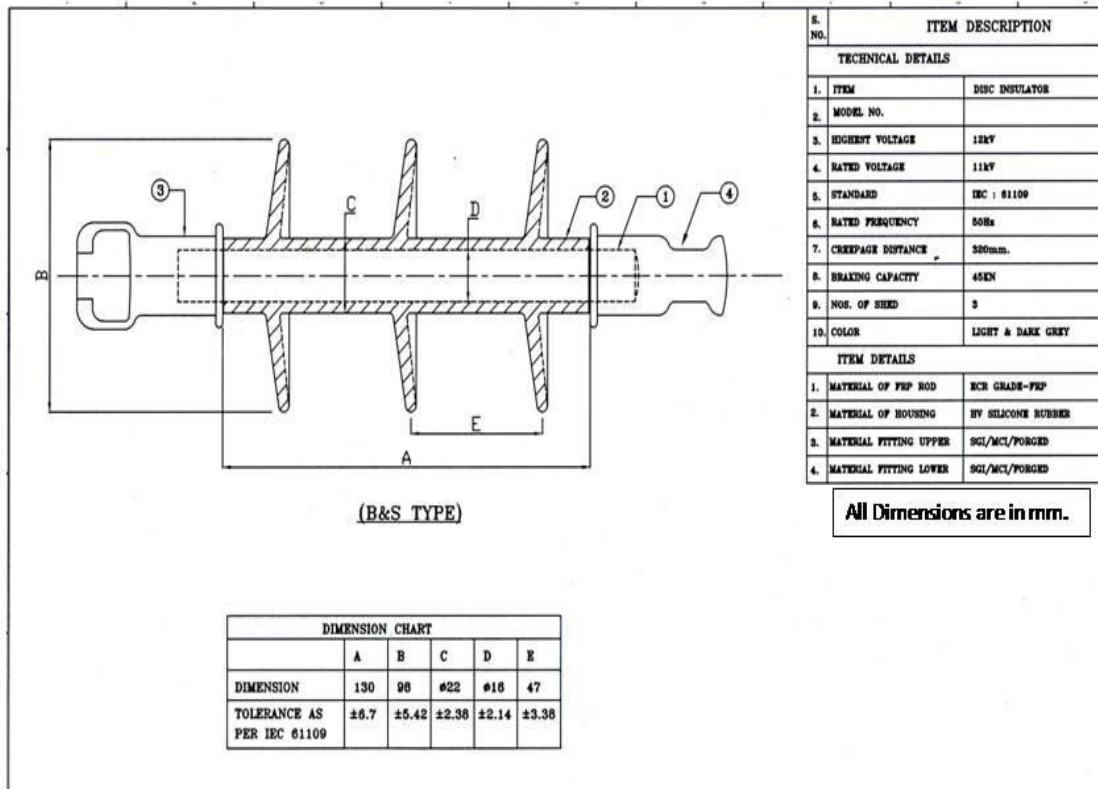

## 5.0 PACKING & MARKING

**5.1 PACKING :-** 11KV composite polymeric Disc Insulator shall be delivered suitably packed. Although the method of packing is left to the discretion of the manufacturer it should be robust enough for rough handling that is occasioned during transportation by road and to avoid damage and breakage of the insulator transshipment in between the road transportation must be avoided i.e. each consignment should be transported from factory to work site.

**5.2 MARKING :-** The following information shall be marked permanently on each Insulator:  
a) Manufacturer's name or Manufacturer's Trade mark  
b) Year of manufacture

**6.0 GUARANTEED TECHNICAL PARTICULARS:-** The guaranteed technical particulars of the 11KV composite polymeric Disc Insulator offered shall be given by the bidder along with the tender

**Guaranteed & other technical particulars for Disc Insulators**



(To be furnished by the Manufacturer)

Sl no.	Description	Unit	Min. requirement for 11 KV 45 KN	To be filled by the bidder
<b>1</b>	Type of Insulator		Polymeric Composite	
<b>2</b>	Standard according to which the insulators manufactured and tested.		IEC 61109:2008	
<b>3</b>	Name of material used in manufacture of the insulator with class / grade)		SILICON Wacker-Germany Dow Corning-USA or equivalent Silicon material as per specification.	
a)	Material of core(FRP rod) (i) E-glass of ECR-glass. (ii) Boom content		ECR or BORRON FREE	
b)	Material of housing & weathersheds (silicon content by weight)		SILICON RUBBER 43 %	
c)	Material of end fittings		SGI	
d)	Sealing compound for end fittings		RTV SILICON	
<b>4</b>	Colour		GREY	
<b>5</b>	Electrical characteristics			
a)	Nominal system voltage		11 KV	
b)	Highest system voltage		12 KV	
c)	Dry Power frequency		70 KV	
d)	Wet Power frequency withstand		45 KV	
e)	Dry flashover voltage		80 KV	
f)	Wet flash over voltage		50 KV	
g)	Dry lighting impulse withstand voltage a) Positive b) Negative		110 KV 110 KV	
h)	Dry lighting impulse flashover voltage a) Positive b) Negative.		120 KV 130 KV	
i)	RIV at 1 MHz when energized at 10 KV /30kV (rms) under dry		<100 micro volts	



j)	Creepage distance ( Min.)		<b>320 MM</b>	
<b>6</b>	Mechanical characteristics : Minimum failing load.		45 KN	
<b>7</b>	Dimensions of insulator			
i)	Weight		1.25 KG(Approx.)	
ii)	Dia of FRP rod		16 MM (Min.)	
iii)	Length of FRP rod		240 MM (Min.)	
iv)	Dia of weathersheds		To be submitted by bidder	
v)	Thickness of housing		3 MM	
vi)	Dry arc distance Dimensioned drawings of insulator (including weight with tolerances in		160+5 MM (+ve tolerance shall be allowed)	
<b>8</b>	Method of fixing of sheds to housing specify). Single mould or Modular construction (injection moulding		Injection moulding	
<b>9</b>	No of weather sheds		3 (min.)	
<b>10</b>	Type of sheds			
i)	Aerodynamic		Aerodynamic	
ii)	With underribs			
<b>11</b>	Packing details			
a)	Type of packing		Strong corrugated box of minimum 7 ply duly paleted/	
b)	No. of insulators in each pack		30 nos.(Maximum)	
c)	Gross weight of package.		50 KG. (Maximum)	
<b>12</b>	Any other particulars which the bidder may			
<b>13</b>	The insulators shall have “W” type phosphors Bronze or “R” type Stainless steel security clips for ball sockets portion of insulators		YES	
<b>14</b>	Length of Crimping dye for crimping at both end of FRP Rod should be minimum		25 MM	





Signature of Authorized  
Signatory of the firm Seal of  
the firm



## 0. EARTHING AND EARTHING G.I PIPE.

**1.0 Scope:-**GI earthing pipe should be made of **40 mm diameter** ISI marked heavy duty A class GI Pipe. **12 mm dia suitable holes** on its circumference shall be made as per approved drawing. The pipe should be in one piece. No joints or welding would be allowed on its length. Clamps made of 50x6mm GI flat duly drilled with 12 mm size holes should be welded at the top end for connection of earth conductor. Pipe used shall be 40mm NB diameter, ISI marked Galvanized Mild Steel Tubes continuously welded Electric Resistance Welded ERW/High Frequency Induction welded (HFIW)/Hot finished welded (HFW) type, conforming to IS-554-1985 with latest amendment of Heavy duty quality (Class B).

**2.0 MANUFACTURE:-** Earthing pipe should be made of 40 mm diameter ISI marked B class GI Pipe. 12 mm dia suitable holes on its circumference shall be made as per approved drawing. The pipe should be in one piece. No joints or welding would be allowed on its length. Clamps made of 50x6mm GI flat duly drilled with 12 mm size holes should be welded at the top end for connection of earth conductor.

GI earth pipe (**40 mm diameter & 2.5 meter long**) shall be made of tubes which shall be made from tested quality steel manufactured by any approved process as follows:

- a) Electric Resistance Welded (ERW).
- b) High Frequency Induction Welded (HFIW) and
- c) Hot finished Welded (HFW).

Tubes made by manual welding are not acceptable.

### 3.0 DIMENSIONS

The dimensions and weights of tubes shall be in accordance with Table-I and Table-II of IS: 1239 (Part-I)/1990 with latest amendments, subject to tolerance permitted therein. Necessary 12 mm diameter holes across the circumference shall be provided as per approved drawing. Drawings shall be approved by the owner before start of the manufacturing work. The tube, earthing pipe shall be provided with **50x6mm GS** clamps on one end, one clamp is to be welded with the pipe and another is removable to enable measurement of earth resistance of the pit. Other end of the earth pipe should be cut half in slop to make it a sharp.

### 4.0 GALVANIZING

Tubes shall be galvanized in accordance with IS-4736-1986 with latest amendment for not (hot) dip zinc coating of Mild Steel Tubes. The minimum mass of zinc coating on the tubes shall be in accordance with clause 5.1 of IS-4736-1986 (specification for hot dip zinc) and when determined on a 100mm long test piece in accordance with IS: 6745:1972 shall be 400 g/m<sup>2</sup>. The zinc coating shall be uniform adherent reasonably smooth and free from such imperfections as flux, ash and dross inclusions, bare patches, black spots, pimples, lumpiness, rust, stains, bulky white deposits and blisters.

### 5.0 HYDRAULIC TEST

(Before applying holes) Each tube shall withstand a test pressure of 5 M Pa maintained for at least 3 seconds without showing defects of any kind. The pressure shall be applied by



approved means and maintained sufficiently long for proof and inspection. The testing apparatus shall be fitted with an accurate pressure indicator.

## 6.0 TEST ON FINISHED TUBES AND SOCKETS

The following tests shall be conducted by the manufacturer of finished tubes and sockets.

- i. The tensile strength of length of strip cut from selected tubes when tested in accordance with IS-1894-1972, (Method for tensile testing of steel tubes), shall be at least 320N/mm<sup>2</sup>.
- ii. The elongation percentage on a gauge length of 5.65/s<sub>0</sub> (where s<sub>0</sub> is the original cross sectional area of test specimen) shall not be less than 20%.
- iii. When tested in accordance with IS-2329-1985 (Method for Bend test on Metallic tubes) the finished tube shall be capable of with standing the bend test without showing any sign of fracture or failure. Welded tubes shall be bent with the weld at 90 degree to the plane of bending. The tubes shall not be filled for this test.
- iv. Galvanized tubes shall be capable of being bent cold without cracking of the steel, through 90 degree round a former having a radius at the bottom of the groove equal to 8 times the outside diameter of tube.
- v. Flattening Test on Tubes above 50 mm Nominal Bore: Rings not less than 40 mm in length cut from the ends of selected tubes shall be flattered between parallel plates with the weld, if any, at 90 degree (point of maximum bending) in accordance with IS-2328- 1983. No opening should occur by fracture in the weld unless the distance between the plates is less than 75 percent of the original outside diameter of the pipe and no cracks or breaks in the metal elsewhere than in the weld shall occur, unless the distance between the plates is less than 60% of the original outside diameter. The test rings may have the inner and outer edges rounded.

## 7.0 GALVANIZING TEST

- i. Weight of zinc Coating: For tubes thickness upto 6 mm the minimum weight of zinc coating, when determined on a 100 mm long test piece in accordance with IS-4736-1986 shall be 400 gm/m<sup>2</sup>.
- ii. The weight of the coating expressed in gram/m<sup>2</sup> shall be calculated by dividing the total weight of the zinc (inside plus outside) by the total area (inside plus outside) of the coated surface.
- iii. Test specimen for this test shall be cut approximately 100 mm in length from opposite ends of the length of tubes selected for testing. Before cutting the test specimen, 50 mm from both ends of the samples shall be discarded.
- iv. Free Bore Test: A rod 230mm long and of appropriate diameter shall be passed through relevant nominal bore of the sample tubes to ensure a free bore.
- v. Uniformity of Galvanized Coating: The galvanized coating when determined on a 100 mm long test piece [see V (a) (iii)] in accordance with IS-2633-1986 (Method for testing uniformity of coating on zinc coated articles) shall with stand 4 one minute dips.

**8.0 WORKMANSHIP:-**The tubes shall be cleanly finished and reasonably free from injurious defects. They shall be reasonably straight, free from cracks, surface flaws, laminations, and other defects, both internally and externally. The screw tubes and sockets shall be clean and well-cut. The ends shall be cut cleanly and square with the axis of tube.



**9.0 MARKING:-**The medium class of tubes shall be distinguished by Blue color bands which shall be applied before the tubes leaves the manufacturers' works. Tubes shall be marked with the standard mark.

### **10.0 EARTHING ARRANGEMENT OF DISTRIBUTION TRANSFORMERS**

**10.1** The earth pits should be located as per REC Construction Standard F-5 (Annexure VI).

**10.2** Pipe earth electrodes should be provided in each earth pit as per REC construction standard J-1 and J-2 (Annexure VII & VIII).

**10.3** 4 mm (8 S.W.G), G.I. wire should be used for earth leads.

**10.4** One of the earth electrodes on either side of D.P. structure should be connected with;

- (a) One direct connection from the L.T. Lightning arresters and cross-arm.
- (b) One direct connection with Lightning arrester on H.T. side (11KV) and cross-arm.

**10.5** To each of the remaining two earth electrodes, the following should be connected:-

- (a) One separate connection from the neutral (on medium voltage side) of the transformer.
- (b) One separate connection from the transformer body and the handle of 11KV A.B. switch.
- (c) One separate connection from the earthing terminal of the poles.



CONSTRUCTION STANDARD

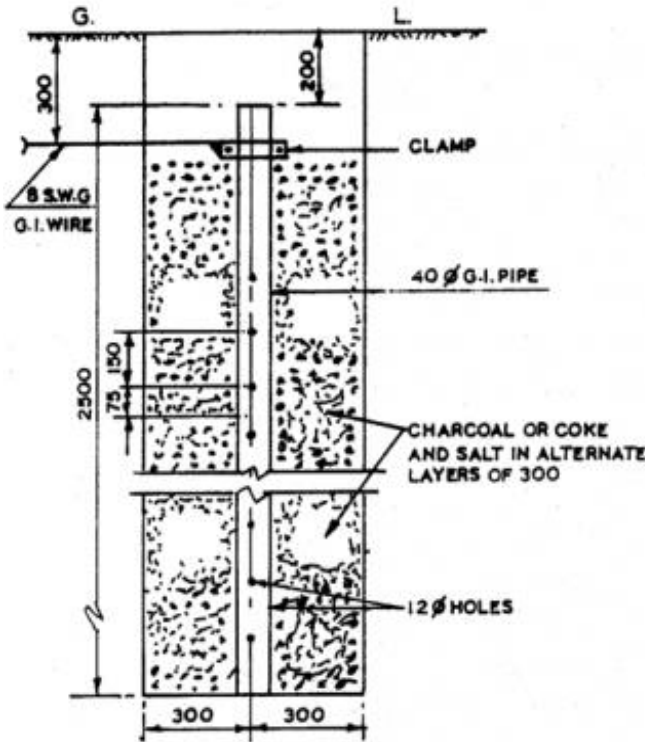

EARTHING FOR HARD, STIFF  
OR MEDIUM CLAY

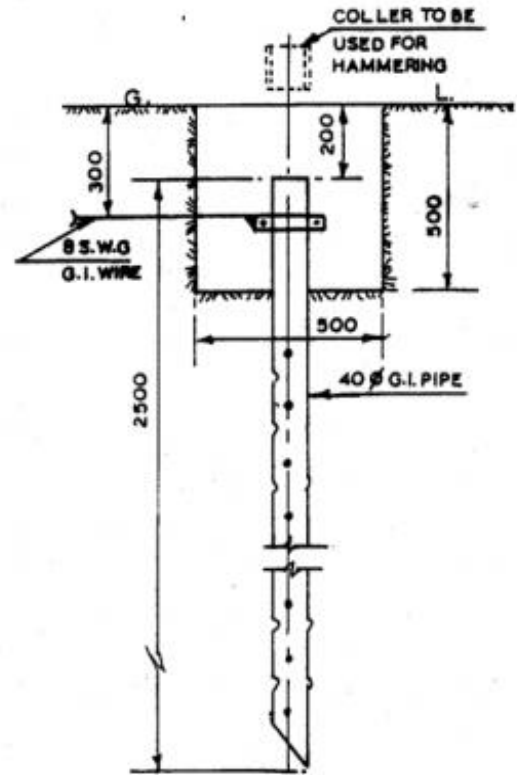

EARTHING FOR ORDINARY SOIL  
WHERE PIPE COULD BE HAMMERED IN

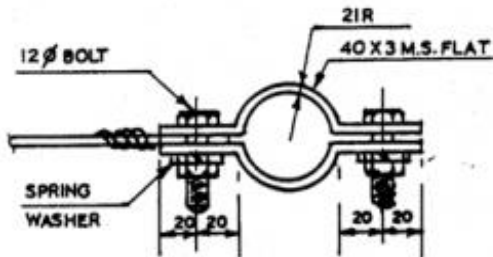

TYPICAL DETAIL OF CLAMP  
FOR PIPE EARTH

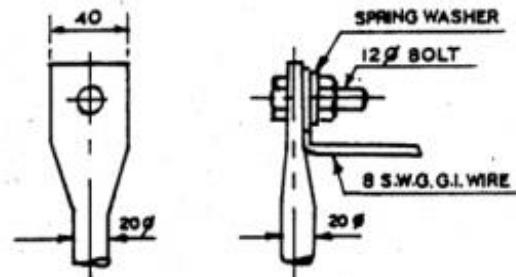

TYPICAL DETAIL OF CONNECTION  
FOR ROD EARTH

NOTES:-

1. ALTERNATIVELY 20 Ø G.I. ROD MAY BE USED INSTEAD OF PIPE.
2. WATER TO BE POURED INTO SUMP TO KEEP THE SOIL SURROUNDING THE EARTH PIPE/ROD MOIST.
3. FOR COIL EARTHING REFER CONSTRUCTION STANDARD. J-1.

ALL DIMENSIONS ARE IN mm.

**PIPE / ROD EARTHING**

SCALE:- N.T.S

SEPT, - 1972



## P. Danger Notice Plate.

**1.0 SCOPE:-**This Specification covers manufacture, supply at site and erection of Danger Notice Plates to be displayed in accordance with rule **No. 35 of Indian Electricity Rules, 1956.**

### 2.0 APPLICABLE STANDARDS

Unless otherwise modified in this specification, the Danger Notice Plates shall comply with **IS: 2551-1982** or the latest version thereof.

### 3.0 DIMENSIONS

(i) Two sizes of Danger Notice Plates as follows are recommended:

a) For display at 415 V installations - **200x150mm**

b) For display at 11 KV (or higher voltages) installations - **250x200mm**

(ii) The corners of the plate shall be rounded off.

(iii) The location of fixing holes as shown in Figs. 1 to 4 is provisional and can be modified to suit the requirements of the owner.

### 4.0 LETTERINGS

All letterings shall be centrally spaced. The dimensions of the letters, figures and their respective position shall be as shown in figs. 1 to 4. The size of letters in the words in each language and spacing between them shall be so chosen that these are uniformly written in the space earmarked for them.

### 5.0 LANGUAGES

**A. Under Rule No. 35 of Indian Electricity Rules, 1956,** the Employer of every medium, high and extra high voltage installation is required to affix permanently in a conspicuous position a danger notice in Hindi or English and, in addition, in the local language, with the sign of skull and bones.

**B.** The type and size of lettering to be done in Hindi is indicated in the specimen danger notice plates shown in Fig. 2 and 4 and those in English are shown in Figs. 1 and 3.

**C.** Adequate space has been provided in the specimen danger notice plates for having the letterings in local language for the equivalent of '**Danger**', '**415**' '**11000**' and '**Volts**'.

### 6.0 MATERIAL AND FINISH

The plate shall be made from mild steel sheet of at least **1.6mm** thick and vitreous enameled white, with letters, figures and the conventional skull and cross-bones in signal red color (refer IS:5-1978) on the front side. The rear side of the plate shall also be enameled.

### 7.0 TESTS

The following tests shall be carried out:

i) Visual examination as per IS: 2551-1982

ii) Dimensional check as per IS: 2551-1982

iii) Test for weatherproofness as per IS:8709-1977 (or its latest version)

### 8.0 MARKING



Maker's name and trade mark and the owner's name shall be marked in such a manner and position on the plates that it does not interfere with the other information.

## **9.0 PACKING**

The plates shall be packed in wooden crates suitable for rough handling and acceptable for rail/road transport.



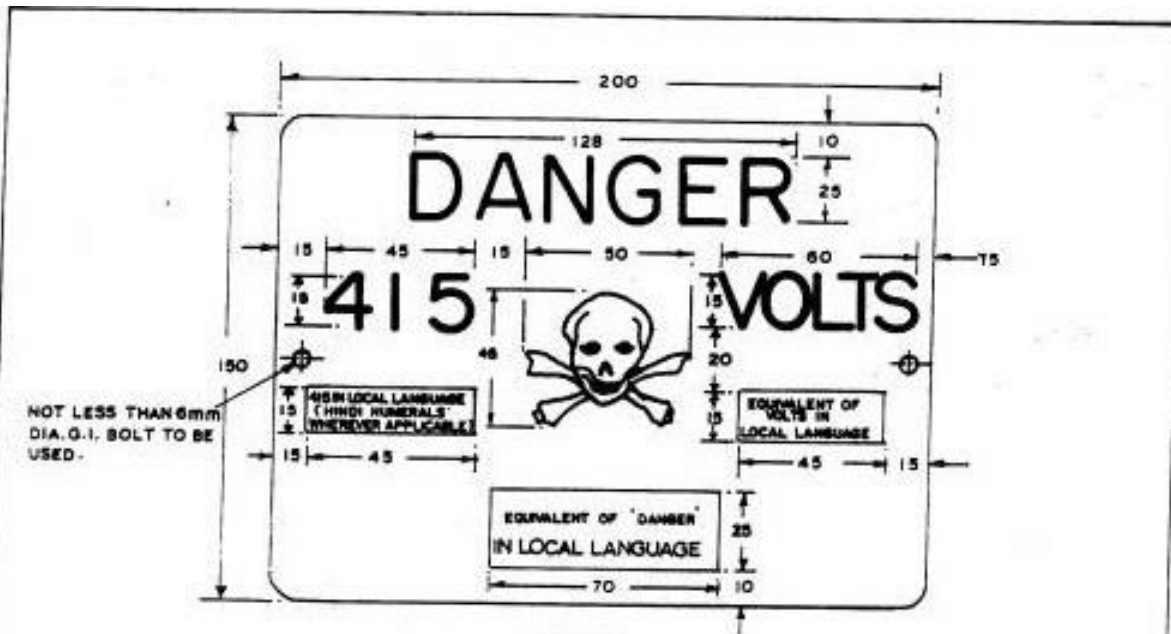

FIG:- 1

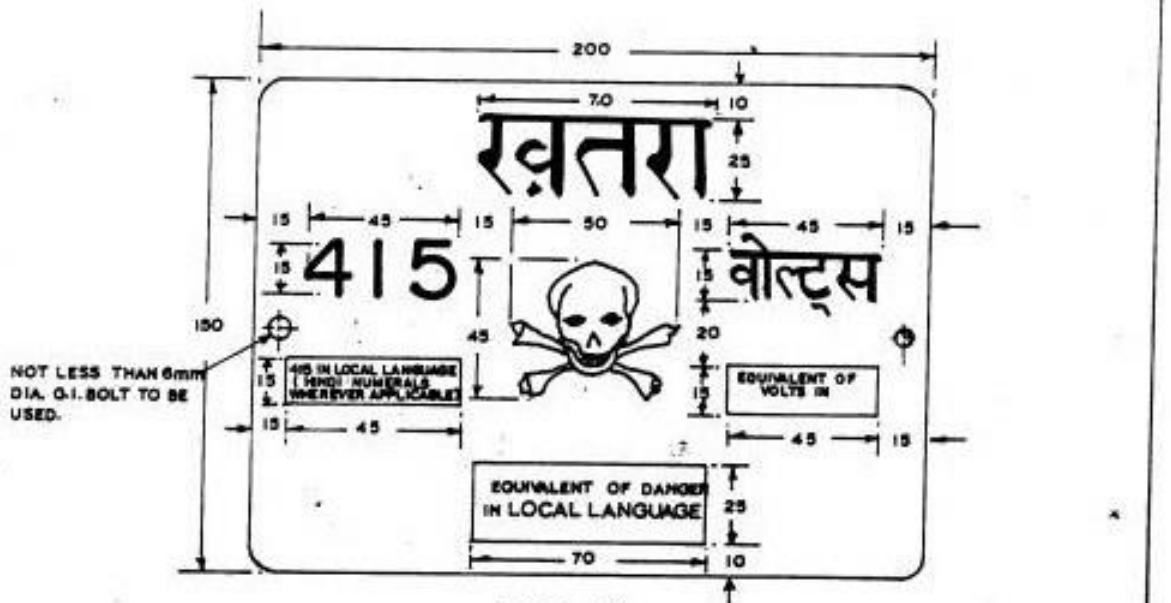

FIG. - 2

ALL DIMENSIONS ARE IN MM.

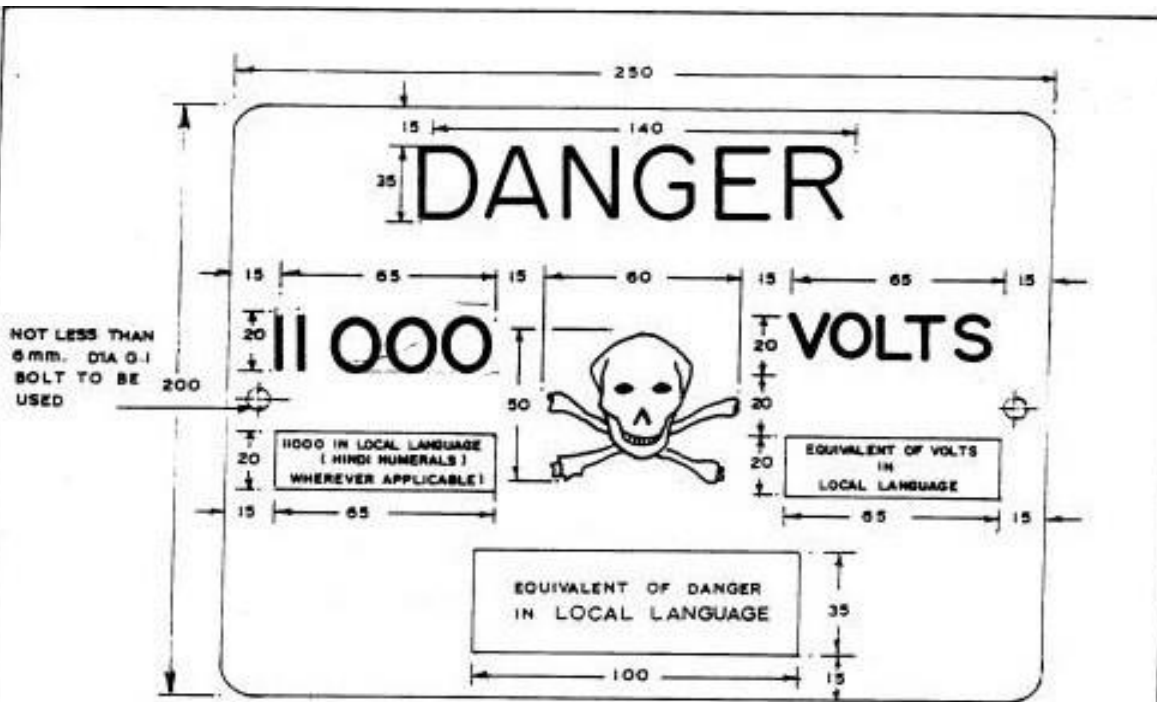

FIG:-3

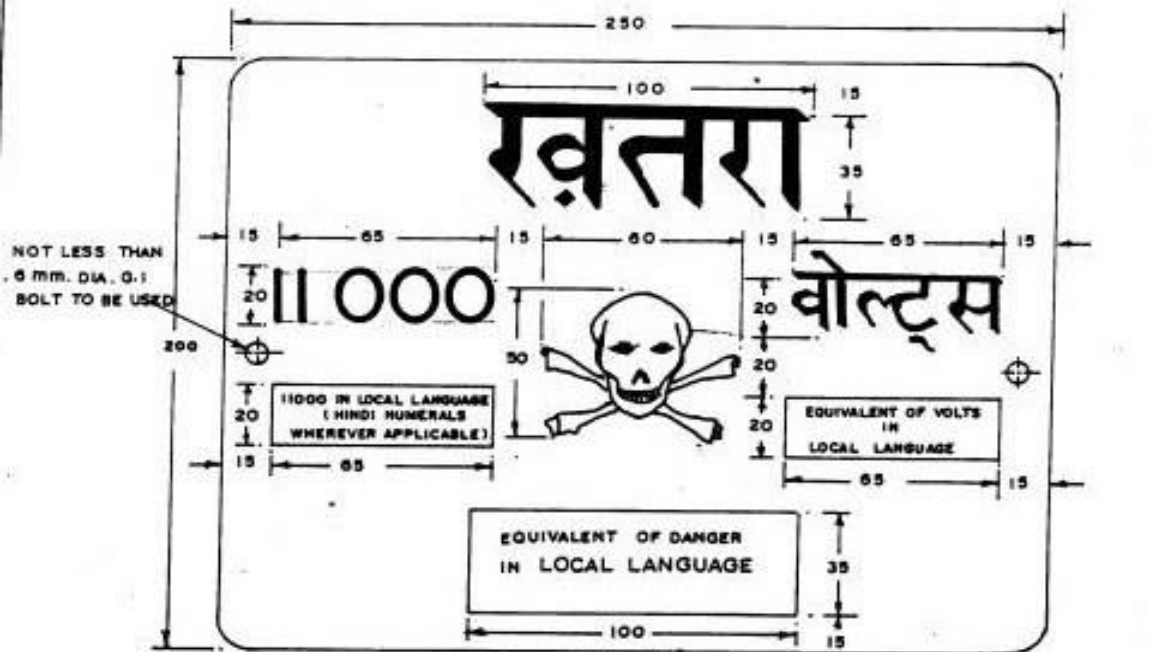

FIG:-4

NOTE: 11000 SHALL BE REPLACED BY 33000, 66000 ETC. AS REQUIRED.

ALL DIMENSIONS ARE IN MM.

Q. TECHNICAL SPECIFICATION FOR L. T. SHACKLE INSULATOR.



1.0 SCOPE:- This specification covers the design, manufacture, testing at works, supply/ delivery & transportation of L.T. shackle insulator conforming to IS: 1445/1977 or as amended latest.

## 2.0 STANDARDS

2.1 The L.T. shackle insulator shall conform in all respect to the relevant Indian/ International Standard Specification, with latest amendments.

### SPECIFICATION FOR L. T. SHACKLE INSULATOR AS PER IS: 1445/1977

- 1) Type of Insulator: - Brown Glazed Porcelain Low Tension Shackle Insulator.
- 2) Standard: -IS:1445/1977
- 3) Leakage distance in mm: - 63mm
- 4) Working voltage: - Up to 1000V
  - 5) Power frequency withstand voltage in Kv: - i) Dry in Kv - 23Kv  
ii) Wet in Kv - 10Kv
  - 6) Power frequency puncture voltage in Kv:- 40 Kv (1.3 x the actual dry flashover voltage)
  - 7) Mechanical Strength in KN:- 11.5 KN
  - 8) Net weight (approx.) in Kg. : - 0.5 Kg.
  - 9) Colour: - Brown Glazed
  - 10) Materials of Insulator: - Porcelain.
  - 11) Content of each package:- 40 pieces.
  - 12) Dimensions as per Drawing(shown below):- H = 75mm, R = 90mm & r = 15mm

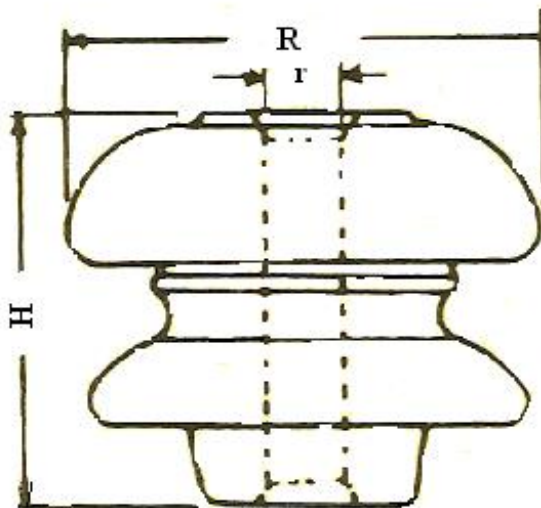

L. T. Shackle Insulator

## 3.0 SERVICE CONDITIONS

The L.T. shackle insulator to be supplied against this Specification shall be suitable for satisfactory continuous operation under the following climatic conditions as per IS: 1445-1977 or latest revision.



i. Location:	At various locations in Tripura.
ii. Max. ambient air temperature (Deg0 C):	500C
iii) Maximum relative humidity Saturation point)	95%(sometime approaches
vi. Max. Altitude above mean sea level(Meters):	1000 M.

#### 4.0 TEST AND INSPECTION

4.1 Following tests shall be carried out at the works of the manufacturer as per relevant ISS before delivery of each lot in presence of the representative of purchaser:

A. Type Tests:

- (a) Visual examination,
- (b) Verification of dimensions,
- (c) Dry power frequency voltage withstand test,
- (d) Wet power frequency voltage withstand test,
- (e) Temperature cycle test,
- (f) Mechanical failing load test,
- (g) Power-frequency puncture withstand test,
- (h) Porosity test.

B. Acceptance Tests:

- (a) Verification of dimensions,
- (b) Temperature cycle test,
- (c) Mechanical failing load test,
- (d) Porosity test,
- (e) Check for weight,

C. Routine Tests:

- (a) Visual examination,
- (b) Verification of dimensions,
- (c) Temperature cycle test,
- (d) Mechanical failing load test.
- (e) Porosity test,
- (f) Check for weight.

Sample at random will be selected from the offered lot for the above testing as per IS.

Note : Purchaser reserves the right to get all or any type test carried out on one sample per 1000 insulator at the cost of supplier from any recognized laboratory / government test house.

4.2 The supplier shall furnish the type test / the routine test certificates as part of the condition for supply of L.T. shackle insulator in bulk quantity at the discretion of the purchaser.

#### 4.3.0 INSPECTION

4.3.1 All tests and inspection shall be made at the place of manufacture unless otherwise especially agreed upon by the manufacturer and purchaser at the time of



purchase. The manufacturer shall afford the inspector representing the purchaser all reasonable facilities without charge to satisfy him that the material is being furnished in accordance with specification.

4.3.2 The purchaser reserves the right to have the tests carried out at the cost of the supplier by an independent agency whenever there is dispute regarding the quality of supply.

## 5.0 PACKING & MARKING

5.1 **PACKING:-** The L.T. Shackle insulator shall be so packed that the L.T. Shackle insulator are adequately protected against breakage and damage in ordinary handling and transit. To avoid damage of the L.T. Shackle insulator transshipment in between the road transportation must be avoided i.e. each consignment should be transported from factory to **work site Storeyard**

5.2 **MARKING :-** The following information shall be marked on each Insulator:

Manufacturers' Trade mark  
The Manufacturers' name  
Visible marking 'TSECL/2009-10'.  
ISI certification mark if any

## 6.0 GUARANTEED TECHNICAL PARTICULARS

The guaranteed technical particulars of the L.T. Shackle insulator offered shall be given by the bidder along with the tender.

## 7.0 **Guaranteed & other technical particulars for L.T. shackle insulator** (To be furnished by the Manufacturer)

SL. No	Description
1)	Name of Manufacturer:-
2)	Place of Manufacture:-
3)	Type of Insulator:-
4)	Working Voltage: -
5)	Standard: -
6)	Leakage distance in mm: -
7)	Power frequency withstand voltage in Kv: - i) Dry in Kv - ii) Wet in Kv -
8)	Power frequency puncture voltage in Kv:-
9)	Mechanical Strength in KN:-
10)	Net weight (approx.) in Kg. : -
11)	Colour: -
12)	Dimension of insulator:-



- 13) Materials of Insulator: -
- 14) Content of each package:-
- 15) Marking as per clause No.5.2 of section-IV
- 16) ISI Certification Mark if any:-

Signature of Authorised  
Signatory of the firm  
Seal of the firm



## R. TECHNICAL SPECIFICATION FOR L.T STRAPS & BOLTS

1.1 SCOPE:-This specification covers the design, manufacture, testing at works, supply/ delivery & transportation of L.T. Straps & Bolts conforming to IS: 7935/1975 or latest amendments inclusive of Hot dip Galvanization/ Electroplating of L.T. Straps, Nuts & Bolts and washers etc. as per relevant IS(S).

1.2 STANDARDS :-The L.T. Straps & Bolts shall conform in all respect to the relevant Indian/ International Standard Specification, with latest amendments.

SPECIFICATION FOR L.T STRAPS & BOLTS AS PER IS: 7935/1975.

- 1) Type of Straps & Bolts: - G.I.Straps & Bolts for flexibly attaching a shackle insulator. (A pair of mild steel straps, two number of mild steel bolts with hexagonal head, two number of mild steel nuts with hexagonal head to suit bolts, two numbers of spring washer).
- 2) Standards: -7935/1975 and 1363/1967 or latest version
- 3) Dimensions: -
  - (i) Straps:-185mm x 30mm x 3mm,
  - (ii) Bolts:-12mm dia,115mm Long, 12mm thick Nut
  - (iii) Washer:- 3mm thick Spring washer
- 4) Materials of Straps and Bolts: - Mild Steel Galvanized
- 5) Dimension of Nuts & Bolts: - As per IS:1363/1967
- 6) Galvanization:- (i) Straps & Bolts and other metal parts to be Hot dip galvanized and (ii) Nuts & washers to be electroplated.
- 7) Gross mass of each package:- Maximum 50Kg
- 8). Other dimensions would be in compliance with the Fig.1.

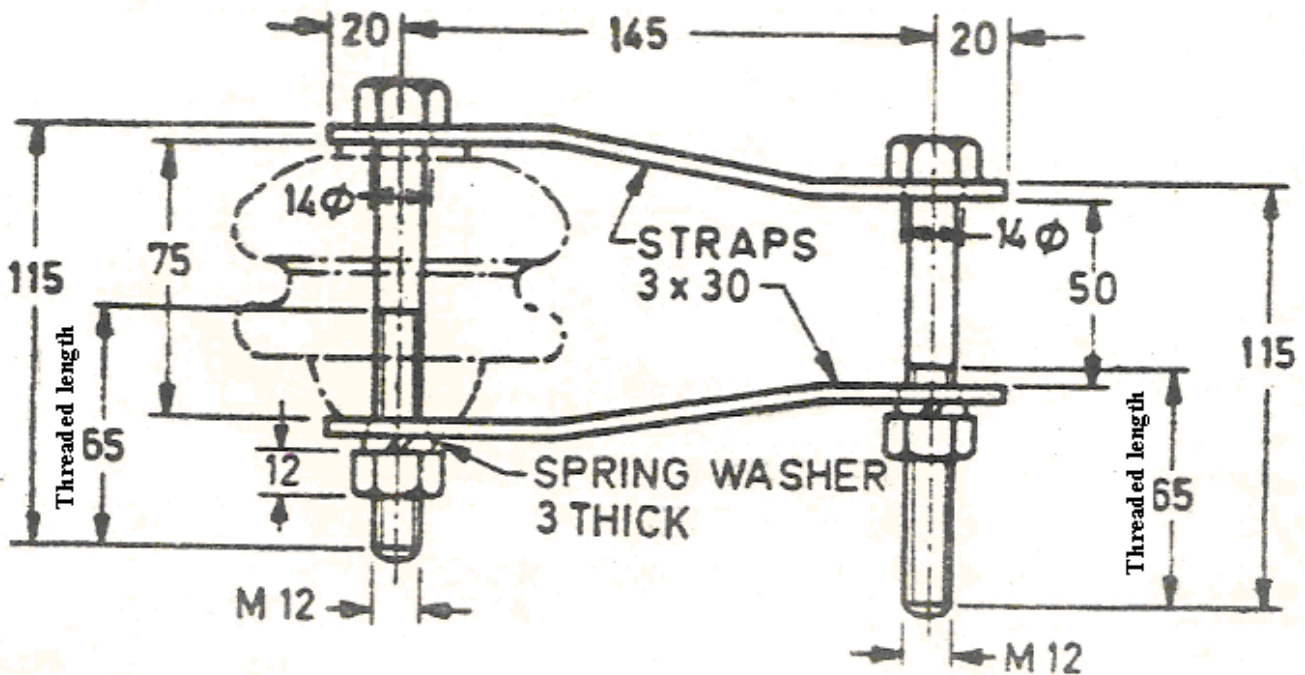

NOTE:- All dimensions are in mm.

Fig-1 L.T.STRAPS & BOLTS





3.0 SERVICE CONDITIONS:-The L.T. Straps & Bolts to be supplied against this Specification shall be suitable for satisfactory continuous operation under the following climatic conditions as per IS:7935/1975 or latest revision.

i. Location:	At various locations in Tripura.
ii. Max. ambient air temperature (Deg0 C):	45
iii. Min. ambient air temperature (Deg0 C):	4
iv. Max yearly daily ambient air temperature (Deg0 C):	40
v. Max average weighed average ambient temperature (Deg0 C ):	32
vi. Max. Altitude above mean sea level(Meters):	1000 M.

#### 4.0 TEST AND INSPECTION

4.1 Following tests shall be carried out at the works of the manufacturer as per relevant ISS before delivery of each lot in presence of the representative of purchaser:

A. Type Tests:

- (a) Visual examination,
- (b) Verification of dimensions,
- (c) Checking of threads on heads,
- (d) Galvanizing / Electroplating test,

B. Acceptance Tests:

- (a) Checking of threads on heads,
- (b) Galvanizing / Electroplating test,
- (c) Verification of dimensions,

C. Routine Tests:

- (a) Visual examination,
- (b) Dimension Test.

Sample at random will be selected from the offered lot for the above testing as per IS.

Note : Purchaser reserves the right to get all or any type test carried out on one sample per 500 Straps & Bolts at the cost of supplier from any recognized laboratory / government test house.

4.2 The supplier shall furnish the type test / the routine test certificates as part of the condition for supply of Straps & Bolts in bulk quantity at the discretion of the purchaser.

#### 4.3.0 INSPECTION



4.3.1 All tests and inspection shall be made at the place of manufacture unless otherwise especially agreed upon by the manufacturer and purchaser at the time of purchase. The manufacturer shall afford the inspector representing the purchaser all reasonable facilities without charge to satisfy him that the material is being furnished in accordance with specification.

4.3.2 The purchaser reserves the right to have the tests carried out at the cost of the supplier by an independent agency whenever there is dispute regarding the quality of supply.

## 5.0 PACKING & MARKING

5.1 **PACKING:-** The L. T. Straps & Bolts shall be so packed in double gunny bags that the Straps & Bolts are adequately protected against breakage and damage in ordinary handling and transit. To avoid damage of the Straps & Bolts transshipment in between the road transportation must be avoided i.e. each consignment should be transported from factory to **work site Storeyard**

5.2 **MARKING :-**The following information shall be marked on each case:

- a) Manufacturers' name
- b) Manufacturers' Trade mark
- c) Visible marking 'TSECL/2008-09'
- d) ISI certification mark if any

6.0 **GUARANTEED TECHNICAL PARTICULARS:-**The guaranteed technical particulars of the L. T. Straps & Bolts offered shall be given by the bidder along with the tender.

## 7.0 **Guaranteed & other technical particulars for L.T. Straps & Bolts.**

(To be furnished by the Manufacturer)

SL. No	Description
1)	Name of Manufacturer:-
2)	Place of Manufacture:-
3)	Type of Straps & Bolts: -
4)	Standards: -
5)	Dimensions: - (i) Straps:- (ii) Bolts:- (iii) Washer:-
6)	Materials of Straps and Bolts: -
7)	Dimension of Nuts & Bolts: -
8)	Galvanization:-
9)	Gross mass of each package:-
10)	ISI Certification Mark if any:-



Signature of Authorised  
Signatory of the firm  
Seal of the firm

**S. TECHNICAL SPECIFICATION FOR ISI MARKED 70mm<sup>2</sup>, 120mm<sup>2</sup>,  
185mm<sup>2</sup> AND 240mm<sup>2</sup> PVC Cable**

**1.0 SCOPE:-**This specification covers the design, manufacture, testing at works, supply/ delivery & transportation of Single core, **16mm<sup>2</sup>, 35mm<sup>2</sup>, 70mm<sup>2</sup>,120mm<sup>2</sup>, 185mm<sup>2</sup> and 240mm<sup>2</sup> PVC insulated, PVC sheathed cable**(heavy duty) with stranded Aluminium conductor, 1100 Volts grade conforming to ISS:1554(P-I)/1988(3rd revision).

**2.0 STANDARDS :-** The 16mm<sup>2</sup>, 35mm<sup>2</sup>, 70mm<sup>2</sup>,120mm<sup>2</sup>, 185mm<sup>2</sup> and 240mm<sup>2</sup> PVC insulated, PVC sheathed cable( shall conform in all respect to the relevant Indian/ International Standard Specification, with with latest amendments as below:

- a) IS: 1554(Part-I)/1983(for cable)
- b) IS: 5831/1984(for PVC Insulation & Sheath)
- c) IS: 8130/1984(for Aluminium Conductor)
- d) IS: 10418/1982(for wooden drum)
- e) IS: 10810/1984(Methods of tests for cable)
- f) IS: 10462(Part-I)/1983(Fictitious Calculation Methods of determination of dimensions of protective coverings of cables)

**3.0 SPECIFICATION FOR 16mm<sup>2</sup>, 35mm<sup>2</sup>& 70mm<sup>2</sup> PVC cable AS PER IS: 1554 (P-I)/1988(3<sup>rd</sup>revision)**

- 1) Type of Cable: - PVC insulated, PVC sheathed cable (heavy duty) with stranded Aluminium conductor
- 2) Voltage Grade: -1100V
- 3) Core: - Single Core
- 4) Nominal cross-sectional area of the conductor:- a) 16mm<sup>2</sup>, b) 35mm<sup>2</sup>, c) 70mm<sup>2</sup>
- 5) Colour of insulation of Core: - Red
- 6) Nominal thickness of

**i) Insulation: -**

- a) 16mm<sup>2</sup> - 1.0mm
- b). 35mm<sup>2</sup> - 1.2mm
- c). 70mm<sup>2</sup> - 1.4mm

**ii) Outer sheath: -**

- a) 16mm<sup>2</sup> - 1.8mm
- b) 35mm<sup>2</sup> - 1.8mm
- c) 70mm<sup>2</sup> -1.8mm

- 7) Tolerance for thickness as per IS:1554(P-I)-1988
- 8) Colour of outer sheath: - Black
- 9) Length of the cable on each drum: -
  - a) 16mm<sup>2</sup> - 500Mtr. (±10%)
  - b) 35mm<sup>2</sup> - 250Mtr. (±10%)
  - c) 70mm<sup>2</sup> - 100Mtr. (±10%)

10) Number of length on each drum: - Single length

11) Cable code: - The following code shall be used for designating the cable:

ConstituentCode Letter



Aluminium conductor	A
PVC Insulation	Y
PVC Outer sheath	

12) Maximum Resistance of Conductor at 20°C:

- a) 16mm<sup>2</sup> - 1.91 Ω / Km
- b) 35mm<sup>2</sup> - 0.868 Ω / Km.
- c) 70mm<sup>2</sup> - 0.443 Ω / Km

13) Number of wire in Conductor :-

- a) 16mm<sup>2</sup> - 7Nos.
- b) 35mm<sup>2</sup> - 7Nos.
- c) 70mm<sup>2</sup> - 19Nos

**14) Insulation and sheath: The type of insulation shall be type A as per IS: 5831 of 1984 with latest amendment/revision if any. The PVC of sheath shall be type ST-1 as per IS-5831 of 1984 (with latest amendment/revision) if any.**

**4.0 SPECIFICATION FOR, 120mm<sup>2</sup>, 185mm<sup>2</sup> AND 240mm<sup>2</sup> PVC cable AS PER IS: 1554 (P-I)/1988(3rd revision).**

1) Type of Cable: - PVC insulated, PVC sheathed cable (heavy duty) with stranded Aluminium conductor

2) Voltage Grade: -1100V.

3) Core: - Single Core.

4) Nominal cross-sectional area of the conductor: - i) 70mm<sup>2</sup> ii) 120mm<sup>2</sup> iii) 185mm<sup>2</sup> iv) 240mm<sup>2</sup>

5) Colour of insulation of Core: - Red

6) Nominal thickness of Insulation: -

- a). 120mm<sup>2</sup> -1.6mm
- b). 185mm<sup>2</sup> -2.0mm
- c). 240mm<sup>2</sup> -2.2mm

ii) Outer sheath: -

- a). 120mm<sup>2</sup> -2.0mm
- b). 185mm<sup>2</sup> -2.0mm
- c). 240mm<sup>2</sup> -2.0mm

7) Tolerance for thickness as per IS:1554(P-I)-1988

8) Colour of outer sheath: - Black

9) Length of the cable on each drum: - 100Mtr. (±10%)

10) Number of length on each drum: - Single length

11) Cable code: - The following code shall be used for designating the cable:

Constituent	Code Letter
Aluminium conductor	A
PVC Insulation	Y
PVC Outer sheath	Y

12) Maximum Resistance of Conductor at 20°C:

- a). 120mm<sup>2</sup> - 0.253Ω / Km
- b). 185mm<sup>2</sup> - 0.164Ω / Km
- c). 240mm<sup>2</sup> - 0.125Ω / Km

13) Number of wire in Conductor :-

- a). 120mm<sup>2</sup> - 37Nos



- b). 185mm<sup>2</sup> - 37Nos
- c). 240mm<sup>2</sup> - 37Nos

**5.0 SERVICE CONDITIONS:-** The 16mm<sup>2</sup>, 35mm<sup>2</sup>, 70mm<sup>2</sup>, 120mm<sup>2</sup>, 185mm<sup>2</sup> and 240mm<sup>2</sup> PVC insulated, PVC sheathed cable (to be supplied and commissioned against this Specification shall be suitable for satisfactory continuous operation under the following climatic conditions as per IS:1554 (PI-I)/1988(3rd revision) or latest revision.

i. Location:	At various locations in Tripura.
ii. Max. ambient air temperature (Deg0 C):	45
iii. Min.ambient air temperature (Deg0 C):	4
iv. . Max yearly daily ambient air temperature (Deg0 C):	40
v. Max average weighed average ambient temperature (Deg0 C):	32
vi. Max. Altitude above mean sea level(Meters):	1000 M.

#### 4.0 TEST AND INSPECTION

1.1 Following tests shall be carried out at the works of the manufacturer as per relevant ISS before delivery of each lot in presence of the representative of purchaser:

A. Type Tests / Acceptance Tests:

- (a) Tensile test,
- (b) Conductor resistance test,
- (c) Wrapping test
- (d) Test for thickness of insulation and sheath,
- (e) Tensile strength and elongation at break of insulation and sheath,
- (f) Insulation resistance test,
- (g) High voltage test (water immersion test) for type test only,
- (h) High voltage test at room temperature.

B. Routine Tests:

- (a) Conductor resistance test,
- (b) High voltage test at room temperature

Sample at random will be selected from the offered lot for the above testing and the lot will be accepted subject to permissible limit of failure as per IS.

Note : Purchaser reserves the right to get all or any type test carried out on one sample per 100 drums of each size of PVC cable at the cost of supplier from any recognized laboratory / government test house.

4.2 The supplier shall furnish the type test / the routine test certificates as part of the condition for supply of PVC cable in bulk quantity at the discretion of the purchaser.

#### 4.3.0 INSPECTION



4.3.1 All tests and inspection shall be made at the place of manufacture unless otherwise especially agreed upon by the manufacturer and purchaser at the time of purchase. The manufacturer shall afford the inspector representing the purchaser all reasonable facilities without charge to satisfy him that the material is being furnished in accordance with specification.

4.3.2 The purchaser reserves the right to have the tests carried out at the cost of the supplier by an independent agency whenever there is dispute regarding the quality of supply.

## 5.0 PACKING & MARKING

5.1 **PACKING:-**The PVC cable shall be supplied in drums conforming to ISS: 10418-1972. The ends of the cable shall be sealed by means of non -hygroscopic sealing materials. The drums shall be suitable for wheel mounting. All wooden components shall be manufactured out of seasoned soft wood free from defects that may materially weaken the component parts of the drums. Preservative treatment shall be applied to the entire drum with preservatives of a quality, which is not harmful to the PVC cable.

The PVC cable drum shall be so packed that the PVC cable are adequately protected against damage in ordinary handling and transit. To avoid damage of the PVC cable transshipment in between the road transportation must be avoided i.e. each consignment should be transported from factory to **work site**.

## 5.2 MARKING

A. The following information shall be marked on each drum:

- a) Manufacturers' name
- b) Manufacturers' Trade mark
- c) Drum or identification number
- d) Size of cable and voltage grade
- e) Length of cable
- f) Gross weight of the package
- g) Net weight of cable
- h) ISI certification mark if any
- i) Running end of cable
- j) Direction of rotation of drum (By means of an arrow)
- k) Year of manufacture

B. The following information shall be marked throughout the length of the cable at an interval of 1(one) metre by embossing on the outer sheath:

- a) Manufacturers' Trade mark
- b) Voltage grade (1100 volt)
- c) Unarmoured

**6.0 GUARANTEED TECHNICAL PARTICULARS:-**The guaranteed technical particulars of The  $16\text{mm}^2$ ,  $35\text{mm}^2$ ,  $70\text{mm}^2$ ,  $120\text{mm}^2$ ,  $185\text{mm}^2$  and  $240\text{mm}^2$  PVC insulated, PVC sheathed cable shall be given by the bidder along with the tender.



Sl. No.	Item	Particulars					
		16mm <sup>2</sup> ,	35mm <sup>2</sup>	70mm <sup>2</sup>	120mm <sup>2</sup>	185mm <sup>2</sup>	240mm <sup>2</sup>
1.	Make & Manufacturer						
2.	Place of Manufacturer						
3.	Type of Cable						
4.	Voltage Grade						
5.	Core						
6.	Nominal cross-sectional area of the conductor						
7.	Colour of Core						
8.	Nominal thickness of i) Insulation						
	ii) Outer sheath						
9.	Tolerance for thickness						
10.	Colour of outer sheath						
11.	Length of the cable in each drum						
12.	Number of length in each drum						
13.	Maximum Resistance of Conductor at 20oC:						
14.	Number of wire in Conductor						
15.	Reference IS code						

Signature of Authorised

Signatory of the firm  
Seal of the firm





## T. TECHNICAL SPECIFICATION FOR 4mm<sup>2</sup> PVC Cable

**1.0 SCOPE:-**This specification covers the design, manufacture, testing at works, supply/ delivery & transportation of Single core, 4mm<sup>2</sup> PVC insulated, PVC sheathed cable(heavy duty) with stranded Aluminium conductor, 1100 Volts grade conforming to ISS:1554(P-I)/1988(3rd revision).

**2.0 STANDARDS :-**The 4mm<sup>2</sup> PVC cable shall conform in all respect to the relevant Indian/ International Standard Specification, with latest amendments.

**SPECIFICATION FOR 4mm<sup>2</sup> PVC CABLE AS PER IS: 1554(P-I)/1988(3rd revision).**

1) Type of Cable: - PVC insulated, PVC sheathed cable (heavy duty) with Stranded Aluminium conductor (Unarmoured)

2) Voltage Grade: -1100V

3) Core: - Single Core

4) Nominal cross-sectional area of the conductor: - 4mm<sup>2</sup>

5) Maximum Resistance of conductor at 20°C:- 7.41 Ω/Km

6) Colour of insulation of Core: - Red

7) Nominal thickness of

i) Insulation: - 1.0mm

ii) Outer sheath: - 1.8mm

8) Grade of Aluminium Conductor: - H2 .

9) Class of Aluminium Conductor: - Class-2

10) Tensile Strength of Aluminium Wire:-Above 100 N/mm<sup>2</sup> to 150 N/mm<sup>2</sup>

11) Elongation at break of Aluminium Wire: - 12%

12) Type of insulation:- 'C'

13) Tensile Strength of Insulation (Minimum):- 12.5 N/mm<sup>2</sup>

14) Elongation at break of Insulation (Minimum):- 125%

15) Type of outer sheath :- ST2

16) Tensile Strength of outer sheath (Minimum):- 12.5 N/mm<sup>2</sup>

17) Elongation at break of outer sheath (Minimum):- 150%

18) Tolerance for thickness as per IS:1554(P-I)-1988

19) Colour of outer sheath: - Black

20) Number of wires in conductor: - 3Nos.

21) Length of the cable on each drum: - 500Mtr. (±10%)

22) Length on each drum: - Single length

23) Cable code: - The following code shall be used for designating the cable:

Constituent	Code Letter
Aluminium conductor	A
PVC Insulation	Y
PVC Outer sheath	Y

Profile of material contents, minimum per Km of 4mm<sup>2</sup> PVC Cable:-

Size of cable	Content in Kg /Km (minimum)			Total weight
	Aluminium	PVC Insulation	PVC outer sheath	
4mm <sup>2</sup>	11	18	55	84



3.0 SERVICE CONDITIONS:- The 4mm<sup>2</sup> PVC cable to be supplied against this Specification shall be suitable for satisfactory continuous operation under the following climatic conditions as per IS: 1554 (PI-I)/1988(3rd revision) or latest revision

- |   |  |
|---|--|
| i. Location:                                    | At various locations in Tripura.           |
| ii. Max. ambient air temperature (Deg0 C):      | 500C                                       |
| iii. Maximum relative humidity                  | 95% (sometime approaches Saturation point) |
| vi. Max. Altitude above mean sea level(Meters): | 1000 M.                                    |

#### 4.0 TEST AND INSPECTION

4.1 Following tests shall be carried out at the works of the manufacturer as per relevant ISS before delivery of each lot in presence of the representative of purchaser:

##### A. Type Tests :-

- (a) Tensile test,
- (b) Conductor resistance test,
- (c) Wrapping test
- (d) Test for thickness of insulation and sheath,
- (e) Tensile strength and elongation at break of insulation and sheath,
- (f) Insulation resistance test,
- (g) High voltage test (water immersion test) for type test only,
- (h) High voltage test at room temperature.
- (i) Flammability Test,
- (j) Thermal Stability Test.

##### B. Routine Tests:

- (a) Conductor resistance test,
- (b) High voltage test at room temperature

##### C. Acceptance Tests:

- (a) Tensile test,
- (b) Conductor resistance test,
- (c) Wrapping test
- (d) Test for thickness of insulation and sheath,
- (e) Tensile strength and elongation at break of insulation and sheath,
- (f) Insulation resistance test,
- (g) High voltage test (water immersion test),
- (h) High voltage test at room temperature
- (i) Flammability Test,
- (j) Thermal Stability Test.

Sample at random will be selected from the offered lot for the above testing and the lot will be accepted subject to permissible limit of failure as per IS.

Note :Purchaser reserves the right to get all or any type test carried out on one sample per 200 drums of PVC cable at the cost of supplier from any recognized laboratory / government test house.



4.2 The supplier shall furnish the type test / the routine test certificates as part of the condition for supply of PVC cable in bulk quantity with the delivery of the material.

#### 4.3.0 INSPECTION

4.3.1 All tests and inspection shall be made at the place of manufacture unless otherwise especially agreed upon by the manufacturer and purchaser at the time of purchase. The manufacturer shall afford the inspector representing the purchaser all reasonable facilities without charge to satisfy him that the material is being furnished in accordance with specification.

4.3.2 The purchaser reserves the right to have the tests carried out at the cost of the supplier by an independent agency whenever there is dispute regarding the quality of supply.

#### PACKING & MARKING

##### 5.1 PACKING

The PVC cable shall be supplied in drums conforming to IS: 10418-1972. The ends of the cable shall be sealed by means of non-hygroscopic sealing materials. The drums shall be suitable for wheel mounting. All wooden components shall be manufactured out of seasoned soft wood free from defects that may materially weaken the component parts of the drums. Preservative treatment shall be applied to the entire drum with preservatives of a quality, which is not harmful to the PVC cable.

The PVC cable drum shall be so packed that the PVC cable are adequately protected against damage in ordinary handling and transit. To avoid damage of the PVC cable transshipment in between the road transportation must be avoided i.e. each consignment should be transported from factory to **work site**.

5.2 MARKING :-The following information shall be marked on each drum:

Manufacturers' name  
Manufacturers' Trade mark  
Drum or identification number  
Size of cable and voltage grade  
Length of cable  
Gross weight of the package  
Net weight of cable  
ISI certification mark if any  
Running end of cable  
Direction of rotation of drum (By means of an arrow)  
Year of manufacture

B. The following information shall be marked permanently throughout the length of the cable at an interval of 1(one) metre either by printing with indelible white ink/colour or by embossing on the outer sheath:

- a) Manufacturer's Trade mark
- b) Voltage grade (1100 volt)
- c) TSECL-2009-10

#### 6.0. Guaranteed & other technical particulars for 4mm<sup>2</sup> PVC cable (To be furnished by the Manufacturer)



Sl.	Description
1.	Make & Manufacturer
2.	Place of Manufacturer
3.	Type of Cable
4.	Voltage Grade
5.	Core
6.	Nominal cross-sectional area of the conductor
7.	Colour of Core
8.	Nominal thickness of
	i) Insulation
	ii) Outer sheath
9.	Grade of Aluminium Conductor
10.	Class of Aluminium Conductor
11.	Tensile Strength of Aluminium Wire
12.	Elongation at break of Aluminium Wire
13.	Type of insulation
14.	Tensile Strength of Insulation (Minimum)
15.	Elongation at break of Insulation (Minimum)
16.	Type of outer sheath
17.	Tensile Strength of outer sheath (Minimum)
18.	Elongation at break of outer sheath (Minimum)
19.	Tolerance for thickness
20.	Colour of outer sheath
21.	Length of the cable in each drum
22.	Number of length in each drum
23.	Maximum Resistance of Conductor at 20oC:
24.	Number of wire in Conductor
25.	Marking as per Clause – 5.2. of section-IV
26.	Reference IS code

27. Profile of material contents, minimum per Km of 4mm<sup>2</sup> PVC Cable:-

Size of cable	Content in Kg /Km (minimum)			Total weight
	Aluminium	PVC Insulation	PVC outer sheath	
4mm <sup>2</sup>				

Signature of Authorised  
Signatory of the firm



Seal of the firm



## U. TECHNICAL SPECIFICATION FOR BI-METALLIC LUGS

1.0 SCOPE :- This specification covers the design, manufacture, testing at works, supply/ delivery & transportation of Bi-metallic lugs conforming to relevant specifications. Bimetallic lug should be made for electrolytic grade aluminum. Each lug should be copper coated by electrolytic process and rich layer of tin should be mounted through out the lug to protect from Galvanic Corrosion. The lugs shall be such that the rich layer of tin should not peel off during operation. Individual lot should be pre filled with conductive inhibition compound and lug should be duly capped to prevent oozing of compound. The ductility of material should be such that flow ability of material be adequate to flow in to the strand of the conductor and withstand on crimping pressure of 8500 PSI. The cut cross section of the joints shall be homogeneous.

2.0 STANDARDS :- The Bi-metallic lugs shall conform in all respect to the relevant Indian/ International Standard Specification, with latest amendments as available.

### SPECIFICATION FOR BI-METALLIC LUGS AS PER RELEVANT IS

- 1) Type of Bi-metallic lug: - Non-Ferrous Bi-metallic lug.
- 2) Standard: -Relevant IS.
- 3) Materials of Bi-metallic lug :-i).Palm:-EC Grade Forged Copper,  
ii). AL Barrel:-EC Grade Aluminium Rod.
- 5) Finish:- Natural and degreased.
- 6) Welding Process:- High Speed Friction Welding.
- 7) Filling of AL Barrel:- Filled with Oxide inhabiting Compound and sealed by plastic Cap.
- 8) Breaking Load on Bi-metallic Joint (Min):

Sl.No.	Lug Size	Minimum Breaking Load of Bi-metallic Lug Joint.
1.	50 mm <sup>2</sup> -10	306 Kgf.
2.	70 mm <sup>2</sup> -10	428 Kgf.
3.	95 mm <sup>2</sup> -10	581 Kgf.
4.	120 mm <sup>2</sup> -12	734 Kgf.
5.	185 mm <sup>2</sup> -12	1132 Kgf.
6.	240 mm <sup>2</sup> -12	1468 Kgf.
7.	300 mm <sup>2</sup> -12	1835 Kgf.

- 9) Dimensions of Bi-Metallic Lugs as per drawing:-

Sl. No.	Lug Size	Dimensions in mm along with Tolerances								
		ØA ±0.25	ØB ±0.2 5	ØE ±0.2 5	ØD ±1	G ±0.5	L1 ±2	L2 ±2	L ±3	T ±0.5
1.	50 mm <sup>2</sup> -10	9	20	10.5	25	12.5	42	49	87	5
2.	70 mm <sup>2</sup> -10	11	20	10.5	25	12.5	42	49	87	5
3.	95 mm <sup>2</sup> -10	12.5	20	10.5	25	12.5	42	49	87	5
4.	120 mm <sup>2</sup> -	15	25	13.0	30	15	58	67	112	7



	12									
5.	185 mm <sup>2</sup> -12	17	32	13.0	30	15	58	67	112	7
6.	240 mm <sup>2</sup> -12	20	32	13.0	30	15	58	67	112	7
7.	300 mm <sup>2</sup> -12	23.3	34	13.0	30	15	68	73	118	7

10)

Weight of Bi-Metallic Lugs:-

Sl. No.	Lug Size	Weight per piece in gms (Approx.)
1.		
2.	50 mm <sup>2</sup> -10	69
3.	70 mm <sup>2</sup> -10	66
4.	95 mm <sup>2</sup> -10	63
5.	120 mm <sup>2</sup> -12	142
6.	185 mm <sup>2</sup> -12	191
7.	240 mm <sup>2</sup> -12	178
	300 mm <sup>2</sup> -12	202

10) Chemical composition:- i).Alumium(Purity):-99.60%  
ii). Copper (Purity):- 99.95%



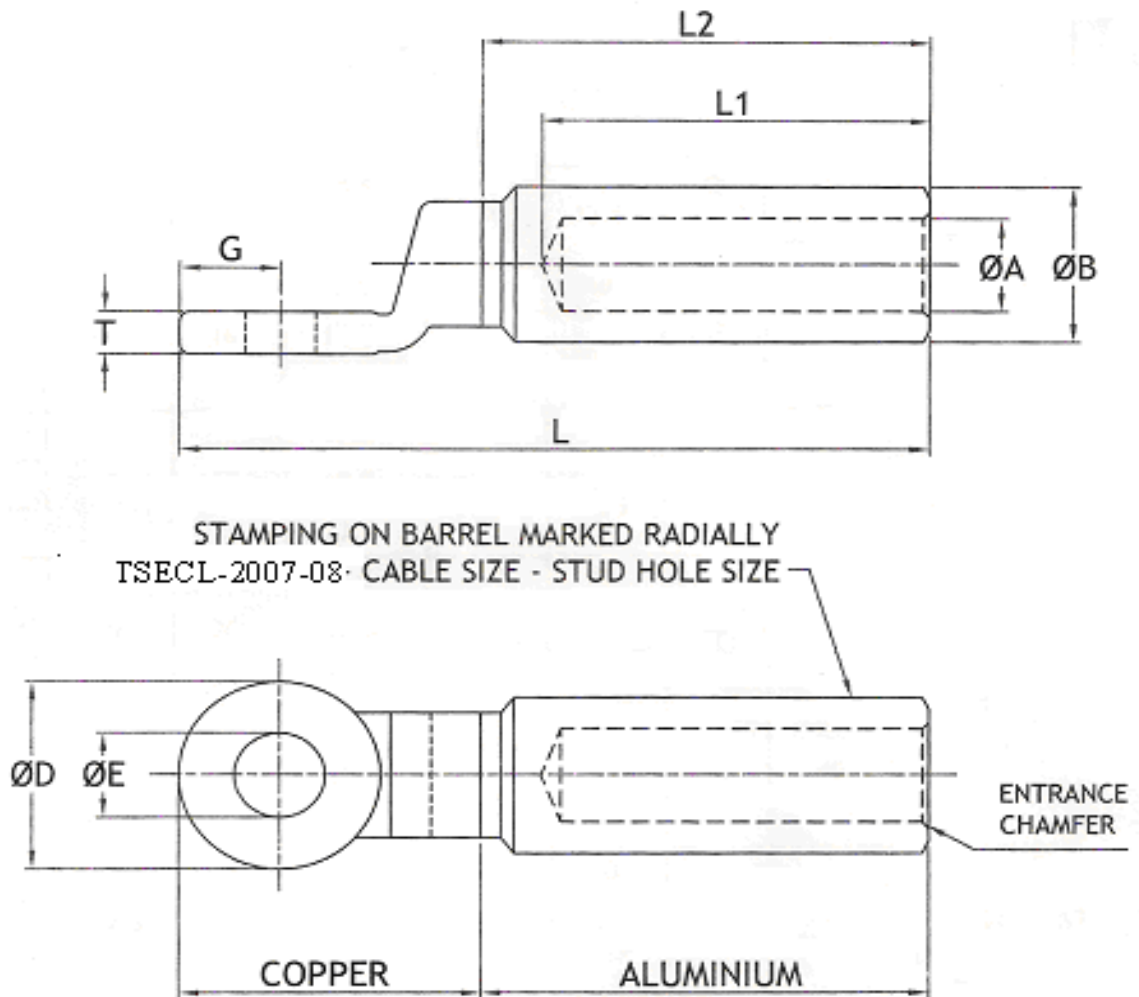

All dimensions are in mm.

### BI-METALLIC LUG

#### 3.0 SERVICE CONDITIONS

The Bi-metallic lugs to be supplied against this Specification shall be suitable for satisfactory continuous operation under the following climatic conditions as per relevant ISS.

i. Location:	At various locations in Tripura.
ii. Max. ambient air temperature (Deg0 C):	45
iii. Min. ambient air temperature (Deg0 C):	4
iv. Max yearly daily ambient air temperature (Deg0 C):	40
v. Max average weighed average ambient temperature (Deg0 C):	32
vi. Max. Altitude above mean sea	



level(Meters): 1000 M.

#### 4.0 TEST AND INSPECTION

4.1 Following tests shall be carried out at the works of the manufacturer as per relevant ISS before delivery of each lot in presence of the representative of purchaser:

A. Type Tests:

- (a) Visual examination test,
- (b) Checking of Dimensions,
- (c) Thermal / Electrical Ageing Test,
- (d) Mechanical Strength Test on Bi-metallic Joint (Breaking Test).

B. Routine Tests:

- (a) Visual examination test,
- (b) Checking of Dimensions,
- (c) Thermal / Electrical Ageing Test,
- (d) Mechanical Strength Test on Bi-metallic Joint (Breaking Test).

C. Acceptance Tests:

- (a) Visual examination test,
- (b) Checking of Dimensions,
- (c) Mechanical Strength Test on Bi-metallic Joint (Breaking Test).

Sample at random will be selected from the offered lot for the above testing as per IS

Note : Purchaser reserves the right to get all or any type test carried out on one sample of Bi-metallic lugs at the cost of supplier from any recognized laboratory / government test house.

4.2 The supplier shall furnish the type test / the routine test certificates as part of the condition for supply of Bi-metallic lugs in bulk quantity at the discretion of the purchaser.

#### 4.3.0 INSPECTION

4.3.1 All tests and inspection shall be made at the place of manufacture unless otherwise especially agreed upon by the manufacturer and purchaser at the time of purchase. The manufacturer shall afford the inspector representing the purchaser all reasonable facilities without charge to satisfy him that the material is being furnished in accordance with specification.

4.3.2 The purchaser reserves the right to have the tests carried out at the cost of the supplier by an independent agency whenever there is dispute regarding the quality of supply.

#### 5.0 PACKING & MARKING

5.1 PACKING :-The Bi-metallic lugs shall be packed in Heat Shrinked Wrapped Corrugated Cartons so that the Bi-metallic lugs are adequately protected against breakage and damage in rough handling during transit and storage at storeyard. The gross weight of the packing shall not normally exceed 25 Kg. To avoid damage of the Bi-metallic lugs transshipment in





3.	95 mm <sup>2</sup> - 10									
4.	120 mm <sup>2</sup> - 12									
5.	185 mm <sup>2</sup> - 12									
6.	240 mm <sup>2</sup> - 12									
7.	300 mm <sup>2</sup> - 12									

10) Weight of Bi-Metallic Lugs:

Sl. No.	Lug Size	Weight per piece in gms (Approx.)
1.		
2.	50 mm <sup>2</sup> -10	
3.	70 mm <sup>2</sup> -10	
4.	95 mm <sup>2</sup> -10	
5.	120 mm <sup>2</sup> -12	
6.	185 mm <sup>2</sup> -12	
7.	240 mm <sup>2</sup> -12	
8.	300 mm <sup>2</sup> -12	

11) Chemical composition:- i).Alumium:-  
ii). Copper:-

Signature of Authorized  
Signatory of the firm

Seal of the firm



## V. TECHNICAL SPECIFICATION OF GUY INSULATOR TO BE USED FOR L.T AND H.T OVERHEAD LINE.

**1.0 SCOPE:-** This specification covers design, engineering, manufacture, assembly, inspection, testing at manufacturer's workshop before dispatch, packing, supply, delivery, & transportation upto destination of porcelain guy strain insulators.

**2.0 CLIMATIC CONDITIONS:-** As mentioned in the General Climatic Conditions in clause 1 of Sec-III.

### 3.0 APPLICABLE STANDARDS

Except when they conflict with the specific requirements of this specification, the insulators shall comply with IS: 5300-1969 or the latest version thereof.

### 4.0 GENERAL REQUIREMENTS

4.1 The porcelain shall be sound, free from defects, thoroughly vitrified and smoothly glazed.

4.2 The design of the insulators shall be such that the stresses due to expansion and contraction in any part of the insulator shall not lead to its deterioration.

4.3 The glaze shall be white in colour for designation A insulators & brown in colour for designation C insulators. The glaze shall cover the entire porcelain surface parts except those areas that serve as supports during firing.

**5.0 TYPE OF INSULATORS:-** The standard guy strain insulators shall be of designation 'A' and 'C' as per IS: 5300/1969 or its latest revision. The recommended type of guy strain insulators for use on guy wires of overhead lines of different voltage levels are as follows:

Power line voltage	Designation of insulators
450 v	A
11000V	C

### 6.0 INSULATED CHARACTERISTICS:

The dimensions of guy strain insulators, basic insulated level, minimum creepage distance & mechanical strength etc. shall be as follows.

Sl No	Parameters	Designation of Insulators	
		A	C
1	Nominal System voltage- V (rms)	415/240V	11000V
2	Length (mm)	90	140
3	Diameter (mm)	65	85
4	Cable hole Dia (mm)	16 ±1.5	25 ±1.5
5	Min. failing load (kN)	44	88
6	Min. creepage distance (mm)	41	57
7	Dry one min. Power Frequency Withstand voltage kV(rms)	18	27
8	Wet one min. Power Frequency Withstand	8	13



	voltage kV(rms)		
--	-----------------	--	--

**7.0 TESTS**

The insulators shall comply with the following routine, type and acceptance tests as per IS: 5300.

**7.1 Type tests**

- a) Visual examination
- b) Verification of dimensions
- c) Temperature cycle test
- d) Dry one minute power frequency withstand test
- e) Wet one minute power frequency withstand test
- f) Mechanical strength test
- g) Porosity test

**7.2 Acceptance test**

(To be conducted in the following order):

7.2.1 The insulators, after having withstood the routine test shall be subjected to the following acceptance tests in the order given below:

- a) Verification of Dimensions.
- b) Temperature cycle test
- c) Mechanical strength test
- d) Porosity test

7.2.2 The number of insulators to be selected at random from the lot shall be in accordance with the table 2 of IS : 5300/1969 which is reproduced bellow:

Lot size	First Sample Size
Up to 500	20
501 to 1000	30
1000 to 2500	50

7.2.3 The insulators selected in accordance with 7.2.2 above shall be divided upto two equal parts and subjected to the tests indicated as below:

Tests	Part of sample
a) & b)	Both parts
c)	First part
d)	Second part



If more than one insulator fails to comply with any of the acceptance tests, the lot shall be rejected.

If one insulator fails to comply with any of the tests, a fresh quantity equal to twice the first quantity shall be subjected to retesting. The retesting shall comprise the test in which the failure occurred preceded by those test which may be considered to have influenced the results of the original tests. If no failure occurs in the re-test, the lot shall be accepted.

### 7.3 Routine tests

- i) Visual examination

### 8.0 TESTING FACILITIES

8.1 The tenderer must clearly indicate what testing facilities are available in the works of the manufacturer and whether the facilities, are adequate to carry out all the routine as well as type tests. These facilities should be made available to T.S.E.C.L.'s Engineers if deputed to carry out or witness the tests. If any tests cannot be carried out at the manufacturer's works, the reasons should be clearly stated in the tender.

8.2 The tenderer shall furnish detailed type test reports of the offered L.T. Stay Insulators as per clause 7.1 of this specification. All the above Type Tests shall be carried out at laboratories, which are accredited, by the National Accreditation Board of Testing and Calibration Laboratories (NABL) of Government of India to prove that the insulators offered meet the requirements of the specification. These Type Tests should have been carried out within five years prior to the date of opening of this tender. However, the tenderers who have supplied the L.T. Stay Insulators to the TSECL against order from Central Purchase Agency of TSECL shall be exempted from submission of Type Test Report against this tender provided.

- i) There offered L.T. Stay Insulators are already fully Type Tested at Laboratories accredited by the National Accreditation Board of Testing and Calibration Laboratories (NABL) within five years prior to the date of opening of the tender.
- ii) There is no change in the design of Type tested L.T. Stay Insulators and those offers against this tender.

The detailed Type Test Reports along with the relevant oscillograms/certified drawings etc. or undertaking seeking exemption from their submission in the format schedule "F" is to be submitted along with the offer.

The successful tenderer shall take approval/waival of Type Test from Owner prior to the commencement of supply.

The Owner reserves the right to demand repetition of some or all the Type test in presence of Owner's representative at Owner's cost. For this purpose, the tenderer shall quote unit rates for carrying out each Type Test. However, such unit rates will not be considered for evaluation of the offer. In case the unit fails in the Type Tests, the complete supply shall be rejected.

8.3 The successful tenderer shall submit a separate test certificate for each batch of insulators manufactured or consignment or part thereof supplied. The test certificate should clearly indicate the results of the routine, and sample tests carried out and the name of laboratory in which the tests were carried out with date of test etc. The certificate issued by recognized testing laboratory, or from their own works will be only accepted.





8.4 If required, the TSECL shall subject the consignment of insulators supplied to the aforementioned test. The testing under this clause will be carried out in any laboratory including T.S.E.C.L.'s own laboratory. Notice of such tests will be given by the TSECL to the contractor by ordinary post. However, the date of testing will not be postponed or altered at the request of the contractor. The contractor is at liberty to be present during this test.

## 9.0 MARKING

9.1 Each insulator shall be legibly and indelibly marked to show the following:

- a) Name or trade mark of the manufacturer
- b) Year of manufacturer
- c) ISI certificate, mark, if any.
- d) 'Marking on porcelain shall be applied before firing.

**10.0PACKING:-**All insulators shall be packed in suitable double gunny bags and shall be transported by road.

## 11.0INSPECTION:

The TSECL may depute an Engineer to witness the routine and sample tests at their manufacturer's works for which advance intimation shall be given the manufacturers whenever a lot is ready for dispatch. All reasonable facilities, should be made available without any charge to the inspector (representing the Owner), to satisfy him that the material, is being supplied in accordance with this specification.

## 12.0GUARANTEED & OTHER TECHNICAL PARTICULARS:

The tenderer shall submit **GUARANTEED & OTHER TECHNICAL PARTICULARS** along with the bid, which is part of the tender specification and offer. If are not submitted duly filled in with the offer, the offer shall be liable for rejection.

### **GUARANTEED TECHNICAL PARTICULARS. L.T. /H.T. GUY STRAIN INSULATORS:**

<b>Sl No</b>	<b>Parameters Name</b>	<b>Parameters Type</b>
1	Type of guy strain insulator L.T.(designation A) / H.T (designation C)	Text
2	Are insulators manufactured as per IS : 5300/1969 or latest revisions thereof.	Boolean
3	Type of material used in manufacture of the insulator	Text
4	Colour of the guy strain insulator shall be white for designation A and Brown for designation C	Text
5	Porcelain used in the manufacture is sound, free from defects, thoroughly vitrified and smoothly glazed.	Text
6	The dimensions of the insulators are as per specified drawings of the specification.	Text
7	Designation of insulator as per IS :5300/1969 (A or C)	Text



8	Minimum failing load of Guy Strain insulator (44 KN / 88 KN)	Text
9	Creepage distance (Min.) for Guy Strain insulator (41mm / 57mm)	Text
10	Cable hole diameter (16mm / 25 mm)	Text
11	Insulator suitable for use with Power line voltage V (rms)	Numeric
12	Dry One Minute Power frequency withstand voltage KV (rms)	Numeric
13	Wet One Minute Power frequency withstand voltage KV (rms)	Numeric
14	Marking on the insulator is as per specification	Text
15	Weight of insulator (Kg)	Numeric
16	Insulators are type tested for the type tests as per specifications & relevant IS and Type Test Reports enclosed.	Boolean
17	Any other particulars <b>which</b> the bidder may like to give	File

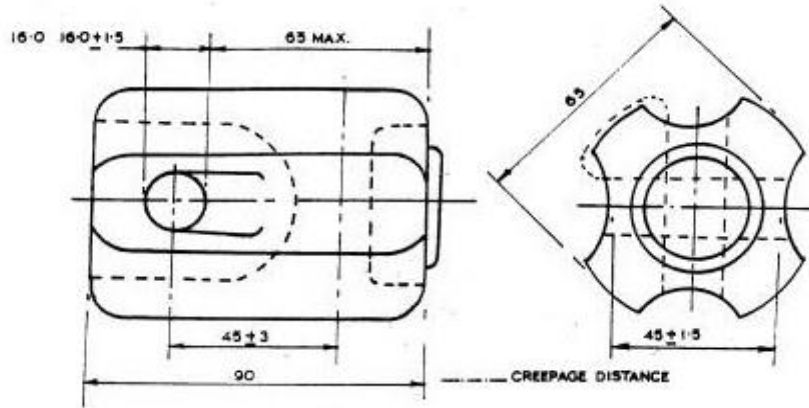

FIG. 1. GUY STRAIN INSULATOR (DESIGNATION - A)

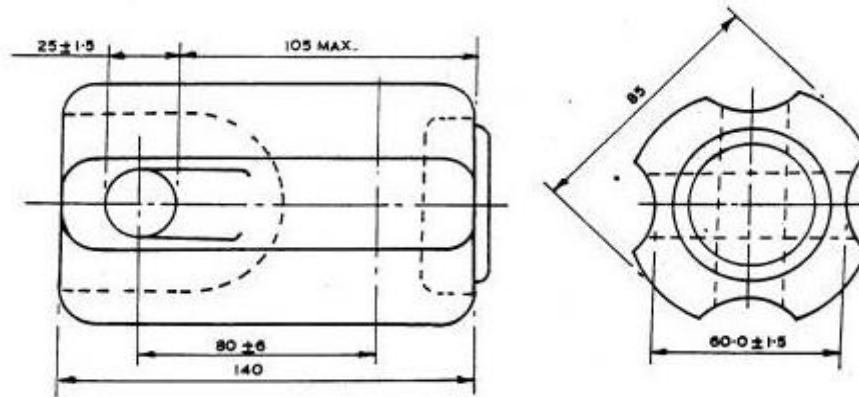

FIG. 2. GUY STRAIN INSULATOR (DESIGNATION - C)



## W. TECHNICAL SPECIFICATION FOR G.I. BARBED WIRE

**1.1 SCOPE:** The specification covers design, manufacture, shop testing, packing and delivery of G.I. Barbed wire by road/ rail.

**1.2 STANDARDS:** Unless otherwise specified elsewhere in this specification, the rating as well as

Performance and testing of the G.I.Barbed wire shall conform to the latest revisions available at the time of placement of order of all the relevant standards but not limited to as listed below.

- 1) IS – 278 / 1978
- 2) IS – 4826 / 1979
- 3) IS – 6594 / 1977

**1.3 GENERAL TECHNICAL REQUIREMENTS:** G.I. Barbed wire shall be of type IOWA with size and dimensions as under:-

Line wire - 2.5 mm

Point wire - 2.0 mm

Distance between two bars shall be 75 mm ( +12 mm ). Wire shall be medium coated by Hot Dip Galvanization as per IS – 4826 / 1979 with upto date amendments.

However, other specific technical particulars shall be as per Annexure- I .

### 1.4 TESTING FACILITIES :

The supplier / tenderer shall clearly state as to what testing facilities are available in the works of manufacturer and whether the facilities are adequate to carry out all the tests specified in the above IS Specifications . The facilities shall be provided by the bidder to employer's representative for witnessing the tests in the manufacturer's works. If any test cannot be carried out at manufacturer's works reason should be clearly stated in the tender.

### 1.5 PACKING :

The wires shall be supplied in 40 to 60 kg per coil. The packing should be done in accordance with IS – 6594 / 1977 or the latest versions thereof . However, the wire shall be supplied in coils ( and not in reels ) . Each coils shall be suitably bound and fastened compactly and shall be protected by suitably wrapping.

### 1.6 SPECIFIC TECHNICAL PARTICULARS FOR 2.5 MM X 2.0 MM G.I.BARBED WIRE

Sl.No	Particulars	Requirement.
1.	Size of wire- mm	Line wire- 2.5 mm $\pm$ 0.08 mm Point wire- 2.0 mm $\pm$ 0.08 mm
2.	Type of Barbed Wire	Iowa Type.
3.	Tensile strength of line wire	390 to 590 N/mm <sup>2</sup>
4.	Minimum breaking load of completed Barbed wire	3.7 kN
5.	Mass of complete Barbed wire	Minimum 115 gms / Mtr.
6.	Distance between two Barbs	(75 +12 ) mm
7.	No. of lays between the Barbs ( minimum )	4
8.	Method of Galvanising	Hot dipped according to IS:4826 /1979 with



		medium coating.
9.	Mass of coating (minimum)	Line wire- 110 gms/Mtr <sup>2</sup> Point wire- 105 gms/Mtr <sup>2</sup> ( testing after barbing )
10.	No. of dips the wire is able to withstand without copper coating A) For Line Wire a) One minute b) Half minute B) For Point Wire a) One minute b) Half minute	( testing after barbing )  2 1  2 Nil



## X. COMMON TECHNICAL SPECIFICATIONS FOR M.S.BOLTS AND NUTS .

- 1. REQUIREMENT:** -M.S. Bolts Black Hexagonal Head Round Neck with Hexagonal Nuts with two washers confirming to IS: 1363/2002 with latest amendments if any. The bolts and nuts shall be ISI marked and Washers shall conform to IS: 2016/1967 with latest amendments if any.
- 2. PACKING:** The bolts and nuts with two washers duly assembled shall be packed in new sound, double jute / woven polythene bags and each pack shall contain maximum 50 Kgs. Net weight.
- 3. BIS LICENSE:** Notarized Xerox copy of valid license for I.S. marking shall be submitted with the tender.
- 4. TYPE TEST CERTIFICATE:** The Bidders have to submit notarized copy of all type test certificate as per IS: 1363/2002 with latest amendments time to time if any, along with Offer.
- 5. GUARANTEED TECHNICAL PARTICULARS FOR SUPPLY OF VARIOUS SIZE M.S. BLACK BOLTS AND NUTS**  
(Bidder has to confirm following important requirement)

Sr. No.	Particulars	Confirmation Please tick YES or NO
1	M.S.Bolts Black hexagonal head round neck with hexagonal nuts with two washers shall be manufactured and supplied conforming to IS: 1363/2002 and Washers shall conform to IS: 2016/1967 with latest amendments if any and DGVCL's specifications	YES / NO
2	M.S.Bolts – Nuts with two washers shall bear ISI mark (Wherever applicable).	YES / NO
3	ISI license shall remain valid till order is completed.	YES / NO
4	Size of M.S. Bolts and Nuts with washers conforming the IS: 2016 - 1967	
5	II. 180mm x 16mm (Length x Diameter) (51 mm thread) (Washers-3.15mm thick, O.D.-30mm, I.D.-18mm)	YES / NO
	III. 65mm x 16mm (Length x Diameter) (38mm thread) (Washers-3.15mm thick, O.D.-30mm, I.D.-18mm)	YES / NO
	IV. 65mm x 12mm (Length x Diameter) (38mm thread) (Washers-3.15mm thick, O.D.-30mm, I.D.-14mm)	YES / NO
6	Packing shall be in new double jute / woven polythene bags and each pack shall contain maximum 50 Kgs. Net weight of Bolts & Nuts with 2 washers duly assembled.	YES / NO



## Y. FENCING OF 11/ 0.433 KV SUB-STATION (with pole mounted DT)

The sub- station area shall be fenced as per Indian Electricity Rules & regulations and shall have provision of lockable gates. Fencing shall be chain link wire mesh on mild steel angle iron posts to a height of not less than 1500 mm. The sub-station area shall be grades and sloped to prevent any water stagnation. Surface shall be covered with ballast of size 15 to 20 mm size.

Galvanized Steel (G.I.) chain link fence fabric conforming to IS:2721:2003, including two line wires of 4.0 mm dia G.I wire ( at top & bottom) having mesh Size - 50 x 50 mm  $\pm$  4 mm ,Nominal dia of Mesh Wire- 2.5 mm Width of Mesh- 1.5 Mtr are to be used for Fencing an area of 2.5 Mtr X 3 Mtr around the 11/0.433 Kv sub-station location,

The fencing will be erected through eye hooks on 10 nos 2.2 mtr long 65 X 65 X 6 mm M.S angle suitably fabricated cleaned and painted with 2 coats of Red Oxide Paint. One two part door, each part of size 1.4 Mtr height and 1.2 mtr width, made off 50 X 50 X 6 mm size MS angle on the periphery and 2 nos 50 X 6 mm MS flat, uniformly spaced & welded ,and holding arrangement of G.I.chain link fence fabric for each part ,with hinges and closing arrangement through door bolt.

The 10 nos 2.2 mtr long 65 X 65 X 6 mm M.S angle posts will be erected on their respective position with digging a pit of 0.4 X 0.4 Mtr and depth of 0.7 Mtr and back filling , ramming and finally grouting with 0.064 cum / post of 1:2:4 CC work with 25 mm jhamma brich aggregate.

## Z. 19/33 KV XLPE insulated, Screened Power cable with Aluminum Conductor.

**1.0 SCOPE:-** The specification covers engineering, design, manufacture, shop testing, packing and delivery at site/store, transportation, insurance, laying and commissioning of 11 & 33 KV , single/multi core , cross linked polyethylene insulated **FRLS PVC Outer sheath** power cables. These cables shall be suitable for the 1/3 phase, AC-50 Hz system with the nominal voltage of 11&33 kV which may reach maximum of 12&36 kV respectively. These cables shall primarily be designed for effectively earthed neutral system.

### 2.0 SERVICE CONDITIONS:

Cables to be supplied against this specification shall be suitable for satisfactory continuous operation under the following tropical conditions.

- a. Maximum ambient temperature (deg C) : 50
- b. Maximum temperature in shade (deg C) : 45
- c. Minimum temperature in air (deg C) in shade : 3.5
- d. Relative Humidity (%) : 10 to 100
- e. Maximum annual Rainfall (mm) : 1450
- f. Maximum Wind Pressure (kg/mm<sup>2</sup>) : 150
- g. Maximum altitude above mean sea level (Meters) : 1000
- h. Isoceraunic level (days/year) : 50
- i. Seismic level (Horizontal acceleration) : 0.3 g.
- j. Moderately hot and humid tropical climate, conducive to rust and fungus growth.

### 3.0 STANDARDS:

3.1 Unless otherwise specified elsewhere in this specification, the rating as well as performance and testing of the HT XLPE power cables shall conform to the latest revisions available at the time of placement of order of all the relevant standards as listed, but not limited to specified.

- 1. **Conductor** : Stranded Class 2 - Annealed Plain / Tinned





2. **Conductor Screen** : Copper / Aluminium – IS:8130 / IEC 60228/ BS 6360.  
: Extruded semi-conducting compound – IS:7098  
Part 2, IEC:60502 Part – 2, BS:6622, BS:7835.
3. **Insulation** : XLPE – IS : 7098 Part 2, IEC:60502 Part – 2,  
BS:6622, BS:7835.
4. **Insulation Non-metallic Screen** : Extruded semi-conducting compound –  
IS:7098  
Part 2, IEC:60502 Part – 2, BS:6622, BS:7835.
5. **Insulation Metallic Screen** : Copper Wire / Tape or Aluminium Wire /  
Strip – IS:7098 Part 2, IEC:60502 Part – 2, BS:6622,  
BS:7835.
6. **Fillers** : Non Hygroscopic PVC \* / Polypropelene Fiber to  
maintain roundness of cable.
7. **Inner sheath/Bedding** : PVC ST 2 as per IS:7098 Part 2, IEC:60502 Part – 2,  
BS:6622, LSOH to BS:7835.
8. **Armour** : IS:7098 Part 2, IS: 3975, IEC:60502 Part – 2,  
BS:6622, BS:7835.
9. **Outer Sheath** : PVC ST 2, FR, FRLS as per IS:7098 Part 2,  
IEC:60502 Part – 2, BS:6622, LSOH to BS:7835.

#### 4.0 GENERAL TECHNICAL REQUIREMENTS:

- 4.1 The High Voltage Aluminium Power cable to be made of Stranded Compact Circutal Aluminium Conductor, Conductor Screened with Extruded Semi conducting compound, XLPE insulated, Insulation Screened with extruded semi conducting compound. Aluminium flat strip armoured and overall sheathed with FRLS quality PVC compound. As per provision of clause 13.1 of IS: 7098 (Part 2) - 1985. The insulation (XLPE) screening shall be provided consisting of extruded semi-conducting cross link material in combination with a metallic layer of copper tapes. Such screened cores shall be laid up together with fillers and/or binder tapes where necessary and provided with extruded inner sheathing of heat resistant PVC conforming to type ST-2 of PVC ST 2 as per IS:7098 Part 2, IEC:60502 Part – 2, BS:6622, LSOH to BS:7835.

Maximum continuous operating temperature shall be 90 deg C under normal operation and 250 deg C under short circuit condition

Armouring shall be provided consisting of single galvanized steel strip (In the case of Single core cable armouring shall be of Non-magnetic material) conforming to IS:7098 Part 2, IS: 3975, IEC:60502 Part – 2, BS:6622, BS:7835. (amended upto date) and over the armouring a tough outer sheath of PVC compound shall be extruded. The PVC compound for the outer sheath shall conform to type ST-2, FRLS as per IS:7098 Part 2, IEC:60502 Part – 2, BS:6622, LSOH to BS:7835. (amended upto date). The colour of the outer sheath shall be black. The cable shall be manufactured strictly conforming to IS:7098 (Part 2) - 1985 amended upto date and shall bear ISI mark.

FRLS Properties - All cable shall be Flame Retardant Low Smoke (FRLS) type. Outer sheath shall have the following properties –

Acid Gas Generation – Max 20% ( as per IEC 754-1)



Smoke density rating: 60% (As per ASTM D 2843)  
 Flammability test - As per Swedish chimney test F3 as per SEN 4241475  
 As per IEC 332 part-3 (Category B)  
 Minimum bending radius shall be 10 D  
 Repaired cables shall not be acceptable.

#### 4.2 SEQUENTIAL MARKING OF LENGTH ON CABLE

Non erasable Sequential Marking of length shall be provided by embossing on outer sheath of the cable for each meter length.

The quality of insulation should be good and insulation should not be deteriorated when exposed to the climatic conditions.

##### 4.2.1 DISCHARGE FREE CONSTRUCTION:

Inner conductor shielding, XLPE insulation and outer core shielding shall be extruded in one operation by special process (viz. Triple Extrusion Process) to ensure that the insulation is free from contamination and voids and perfect bonding of inner and outer shielding with insulation is achieved. The bidders are requested to elaborate the manufacturing technique adopted by their manufacturers to achieve this motive.

**5.0 CONTINUOUS A.C. CURRENT CAPACITY:-** Continuous A.C current capacity shall be as per Table given below.

Conductor sizes in sq. mm.	Continuous A.C. current capacity in Amps. at maximum conductor temp. of 90°C		
	When laid direct in the ground 30°C		When laid in air 40°C
	11 KV	33 KV	11 / 33 KV
70 Sq mm.	160	155	165
95 Sq mm	190	175	200
120 Sq mm	215	195	230
150 Sq mm	240	225	265
185 Sq mm	270	255	310
240 Sq mm	315	290	345
300 Sq mm	355	325	396
400 Sq mm	405	385	460
500 Sq mm	450	450	590

**6.0 SHORT CIRCUIT CURRENT-**Short circuit current of 11 & 33 KV XLPE cable shall be as per Table given below.

Duration of Short Circuit in sec.	Area of Al. Conductor	Short circuit current in kA
T	A	$I=0.094 \times A/\text{sq.rt} (t)$
1	70 Sq mm.	6.58
1	95 Sq mm	8.93
1	120 Sq mm	11.28
1	150 Sq mm	14.10
1	185 Sq mm	17.39
1	240 Sq mm	22.56



1	300 Sq mm	28.20
1	400 Sq mm	37.60
1	500 Sq mm	47.00
1	630 Sq mm	59.20

## 7.0 TESTS AND TESTING FACILITIES:

### 7.1 TYPE TESTS:

All the type tests in accordance with **IS: 7098 Part 2, IEC: 60502, BS: 6622, BS: 7835** and amended upto date, shall be performed on cable samples drawn by purchaser.

Type tests are required to be carried out from the lot of supply on a sample of any one size of cable ordered for each voltage grade. In case facilities of any of the type tests are not available at the works of the supplier, then such type test shall be carried out by the supplier at the independent laboratory at the cost of supplier. Sample for the type test will be drawn by the purchaser's representative and the type test will be witnessed by him.

The following shall constitute type tests:

- a) Tests of Conductor:
  - i) Annealing test (for copper)
  - ii) Tensile test (for aluminium)
  - ii) Wrapping test (for aluminium)
  - iii) Conductor Resistance test
- b) Tests for armouring wires/strips.
- c) Tests for thickness of insulation and sheath.
- d) Physical tests for insulation:
  - i) Tensile strength and elongation at break.
  - ii) Ageing in air oven.
  - iii) Hot test.
  - iv) Shrinkage test.
- v) Water absorption (gravimetric).
- e) Physical test for outer sheath:
  - i) Tensile strength and elongation at break.
  - ii) Ageing in air oven.
  - iii) Shrinkage test.
  - iv) Hot deformation,
- f) Partial discharge test.
- g) Bending test.
- h) Dielectric power factor test:
  - i) As a function of voltage.
  - ii) As a function of temperature.
- i) Insulation resistance (volume resistivity test).
- j) Heating cycle test.
- k) Impulse withstand test.
- l) High voltage test.
- m) Flammability test.

### 7.2 ROUTINE TESTS:

All the Routine tests as per IS:7098 (Part 2) - 1985 and amended upto date shall be carried out on each and every delivery length of cable. The result should be given in test report.



Partial discharge test must be carried out in a fully screened test cell. It is, therefore, absolutely essential that the manufacturer should have the appropriate type of facility to conduct this test which is routine test.

The details of facility available in the manufacturer's works in this connection should be given in the bid.

The following shall constitute routine tests:

- a) Conductor resistance test
- b) Partial discharge test
- c) High voltage test.

### **7.3 ACCEPTANCE TESTS:**

All Acceptance tests as per IS:7098 (Part 2) - 1985 as modified upto date including the optional test and Flammability Test shall be carried out on sample taken from the delivery lot.

### **7.4 SHORT CIRCUIT TEST:**

The contractor shall also undertake to arrange for the short circuit test as a type test on any one size of each voltage grade i.e on one size of 11 kV and one size of 33 kV earthed grade shielded XLPE cables ordered at a recognized testing center such as Central Power Research Institute at Bangalore/ Bhopal at the cost of supplier. If facilities for carrying out short circuit tests are available at the works of the supplier, and provided the certification procedure is approved by the Purchaser, testing at the supplier's works will be acceptable. Short Circuit test shall be witnessed by the purchaser's representative.

7.4.1 The short circuit test shall be preceded and followed by the following tests so as to ensure that the characteristics of the cable remain within the permissible limits even after it is subjected to the required short circuit rating.

- a) Partial Discharge Test.
- b) Conductor Resistance Test.
- c) High Voltage Test.

7.4.2 The manufactured cable will be acceptable only after such a sample test is successfully carried out at CPRI or at suppliers works and approved by the Purchaser.

### **7.5 TESTING FACILITIES**

The supplier / tenderer shall clearly state as to what testing facilities are available in the works of manufacturer and whether the facilities are adequate to carry out type, routine and acceptance tests mentioned in specified IS. The facilities shall be provided by the bidder to purchaser's representative for witnessing the tests in the manufacturer's works. If any test cannot be carried out at manufacturer's works reason should be clearly stated in the tender.

### **8.0 PACKING AND MARKING:**

#### **8.1 IDENTIFICATION MARKS ON CABLE:**

The following particulars shall be properly legible embossed on the cable sheath at the intervals of not exceeding one meter through out the length of the cable. The cables with poor and illegible embossing shall be liable for rejection.

- a) Manufactures name and/or Trade name.
- b) Voltage grade.



- c) Year of manufacture.
- d) Successive Length.
- e) Size of cable
- f) ISI mark

8.2 The cable shall be supplied in continuous standard length of 250 running meters for 3core and 500 running meters with plus minus 5% tolerance wound on non returnable wooden drum of good quality and non-standard lengths not less than 100 meters upto 5% of the ordered quantity shall be accepted. Alternately cable can be supplied wound on non-returnable steel drum without any extra cost to the purchaser. Packing and marking shall be as per clause No. 21 of IS:7098 (Part 2) - 1985 amended up to date.

8.3 Supplier should provide statistical data regarding cables of all sizes viz.-

- 1) Weight of one meter of finished product of cable of various sizes and ratings.
- 2) Weight of one meter of bare conductor used for cables of various sizes and ratings.

### 9.0 QUALITY ASSURANCE PLAN:

A detailed list of bought out items which got into the manufacture of cables should be furnished indicating the name of the firms from whom these items are procured. The bidder shall enclose the quality assurance plan invariably along with offer followed by him in respect of the bought out items, items manufactured by him & raw materials in process as well as final inspection, packing & marking. The Company may at its option order the verification of these plans at manufacturer's works as a pre qualification for technically accepting the bid. During verification if it is found that the firm is not meeting with the quality assurance plan submitted by the firm, the offer shall be liable for rejection.

### 10.0 INSPECTION (TEST BEFORE DISPATCH):

10.1 The inspection may be carried out by the Owner at any stage of manufacturer. The Inspection & Testing shall be governed by **Section-II** (General Conditions OfContract). Acceptance of any equipment / material under this specification by the Owner shall not relieve the supplier of his obligation of furnishing equipment in accordance with the specification and shall not prevent subsequent rejection if the equipment/material is found to be defective. The following **Acceptance tests** as per Clause No.18.2 of IS:7098(Part-II)/1985 shall be conducted in presence of the Owner's authorized representative / agency on each lot of offered cables:

- i) Tensile Test.
- ii) Wrapping Test.
- iii) Conductor Resistance Test.
- iv) Test for thickness of insulation & sheath.
- v) Hot Set Test for insulation.
- vi) Tensile strength& elongation at break test for insulation and sheath.
- vii) Partial Discharge Test (for screened cables only).
- viii) High voltage test and
- ix) Insulation resistance (Volume resistivity) Test.
- x) Test for Armour:
  - a) Verification of Dimension of Strip.
  - b) Tensile Strength & elongation at break.
  - c) Uniformity of Zinc Coating.
  - d) Weight of Zinc Coating.
  - e) Winding Test on Armour.



f) Resistivity Test on Armour.

Cold impact test for outer sheath (IS:5831/1984) shall constitute the optional test and shall be conducted on lot of the offered cables of each size as per Clause No.18.4 of IS:7098(Part-II)/1985.

**11.0 TEST CERTIFICATE:**

- 11.1 Certified copies of all routine tests carried out at Works shall be furnished in Six (6) copies for approval of the purchaser.
- 11.2 The cables shall be dispatched from Works only after receipt of Purchaser's written approval of shop test reports.
- 11.3 Type Test Certificates of the Cable offered shall be furnished. Otherwise the cable shall have to be type tested on similar rating as per Clause – 10 free of any charges to prove the design.

**12.0 DRAWINGS & DOCUMENTATIONS:**

The bidder is required to furnish the detailed constructional drawing of cable clearly showing shape of core, type, size of fillers/ interstices along with Center Filler etc. **The calculations of weights of different components of the cable along with weight of armouring and calculation of number of armour strips indicating Lay Ratio & Lay Factor shall also be furnished. In absence of this, the bids are likely to be ignored. The drawing of drums shall also be furnished as per relevant applicable ISS.**

**13.0 GUARANTEED TECHNICAL PARTICULARS:**

The bidder shall furnish guaranteed technical particulars along with the bid .

**GUARANTEED TECHNICAL PARTICULARS**

**( To be filled in by the Bidder )**

1. Manufacturer's Name & Address ::
2. Voltage Grade. :: 19/33 KV 6.35/11 KV  
(For 33 KV Sys.) ( For 11 KV Sys.)
3. Core & Cross Section ::
4. Type & Designation (as per ISS) ::
5. List of Standards applicable ::
6. Suitable for system with
- (a) Service Voltage ::
- (b) Neutral Earthing ::
7. Maximum Conductor temperature ::
- (a) Continuous (in Deg. C) ::
- (b) Short time (in Deg. C ) ::
8. Conductor:
- (a) Material to IS-8130(Class/Grade) ::
- (b) Size (Sq.mm.) ::
- (c ) No./Nominal diameter of wires in each Conductor (no./mm.) ::
- (d) Form of Conductor (Circular/shaped) ::
9. Shielding/screening on Conductor :
- (a) Material. ::
- (b) Type. ::



- (c) Whether thermosetting ? :: (Yes/No.)
10. Insulation :
- (a) Material. ::
  - (b) Type ::
  - (c) Minimum Thickness (mm) ::
  - (d) Whether tripple co-extrusion :: (Yes/No)  
With radiant curing process ?
11. Shielding / screening on insulation :
- (a) Material ::
  - (b) Type ::
  - (c) Thickness (mm) ::
    - i) Non-metallic ::
    - ii) Metallic ::
12. Inner – sheath ::
- (a) Material ::
  - (b) Type ::
  - (c) Thickness (mm.) ::
  - (d) Extruded/Wrapped. ::
  - (e) Approx. outside diameter ::  
over sheath (mm.)
13. Armouring ::
- (a) Material. ::
  - (b) Size ::
  - (c) D.C. resistance at 20 deg.C ::  
(Ohm/Km.)
  - (d) A.C. resistance at 20 deg.C ::
14. Overall Sheath ::
- (a) Material ::
  - (b) Type ::
  - (c) Thickness (mm.) ::
15. Approx. overall diameter of the :: Cable (mm.)
16. Standard Drum length with tolerance (Mtr.)
17. Net Weight of Cable(approx.)Kg/Km ::
18. Continuous current rating for standard condition, laid direct
- (a) In ground at temp. 30 deg.C ::
  - (b) In duct at temp. 30 deg.C ::
  - (c) In air at temp. 40 deg.C ::
19. Charging current at rated system voltage ::
20. Short Circuit Current (Maxm.) ::
- (a) for 1 sec. ::
  - (b) for 0.5 sec. ::
21. Electrical Parameters ::
- (a) Maxm. D.C. resistance/km of conductor at 20 deg.C ::
  - (b) AC resistance/kilometer of conductor at 90 deg.C(approx.) ::
  - (c) Reactance/kilometer(approx.) ::
  - (d) Capacitance/Kilometer(approx.) ::
  - (e) Di-electric losses at rated  
(Uo/U) system KV, 50 cycles/sec.  
in Watts/KV/Phase) ::
  - (f) i) tan-delta at 0.5 Uo ::





- ii) tan-Delta at  $U_0$  ::
- iii) tan-Delta at  $1.5 U_0$  ::
- iv) tan-Delta at  $2 U_0$  ::
- 22. Vol. Resistivity at 27 deg.C(ohm/Cm) ::
- 23. Recommended minimum bending radius ::
- 24. Derating factor for following ambient temperature in Air/Ground.:
  - (a) at 30 deg. C ::
  - (b) at 35 deg. C ::
  - (c) at 45 deg. C ::
  - (d) at 50 deg. C ::
- 25. Type test results of the similar Cable to be furnished with Tender (as specified under Clause-10 of the Spec.):
  - (a) Tests on Conductor :
    - (i) Tensile test (for aluminium) ::
    - (ii) Wrapping test (for aluminium) ::
    - (iii) Resistance test ::
  - (b) Test for armouring wires/strips ::
  - (c) Test for thickness of insulation & sheath :
    - (i) Tensile strength & elongation at break ::
    - (ii) Ageing in air oven ::
    - (iii) Hot test ::
    - (iv) Shrinkage test ::
    - (v) Water absorption (Gravimetric) ::
  - (d) Physical :
    - (i) Tensile strength and elongation at break::
    - (ii) Ageing in air oven ::
    - (iii) Shrinkage test ::
    - (iv) Hot deformation ::
    - (v) Loss of mass in air oven ::
    - (vi) Heat shock ::
    - (vii) Thermal stability ::
  - (e) Partial discharge test ::
  - (f) Banding test ::
  - (g) Di-electric power factor test :
    - (i) As a function of Voltage ::
    - (ii) As a function of temperature ::
  - (h) Insulation Resistance  
(Volume resistivity)\*Test:
    - (i) Heating Cycle test ::
  - (j) Impulse with stand test ::
  - (k) High Voltage test ::
  - (l) Flammability test ::
- 26. Cable Drums :
  - (a) Length/Drum (Kg) :
  - (b) Dimension of Drum ::
  - (c) Shipping weight (Kg) ::
- 27. Safe pulling force (Kg.) ::
- 28. Partial discharge value ::
- 29. Details of the protective measures against attack by white ants, vermins etc. to be XLPE's outer sheath during manufacture. ::



- 30. Type of curing of XLPE insulations ::
- 31. Cut ends of the Cable shall be sealed with ..... ::
- 32. Cable identification shall be made as per per class 8.10 (Yes/No). ::
- 33. Cable Drums shall be marked with the with the information's of conspicuously (Yes/No)::

## AA. HEAT SHRINKABLE TYPE END TERMINATIONS:

**1.0 SCOPE:** This section covers the standard technical requirements of design, manufacturing, testing at works, and transportation to site, insurance, storage, erection and commissioning of heat shrinkable type terminations suitable for 33 KV single core XLPE insulated, screened, armored, with aluminum conductor cables suitable for earthed system and conforming to IS:7098 (Part-II)-1985 with latest amendment or the equivalent International Standards.

**2.0 STANDARD:-** The performance as well as type test requirements of all type of kits referred under scope shall conform to stipulations of IS:13573/1992 or the equivalent International Standards with latest amendments. All the electrical & physical parameters of terminations should also conform to the corresponding parameters of XLPE cables referred under 'SCOPE' of this specification, as per IS: 7098 (Part-II)-1985 (with latest amendments, if any) or equivalent international standards

### 3.0 CLIMATIC CONDITIONS :

- a. Maximum ambient temperature in open ai(°C) : 50
- b. Maximum ambient temperature in shade (°C) : 45
- c. Minimum temperature in shade(°C) : 3
- d. Relative humidity (%) : 10 to 100
- e. Maximum annual rainfall (mm) : 1450
- f. Maximum wind pressure (Kg/ Sqmtr.) : 150
- g. Maximum altitude above mean sea level (Mtrs) : 1000
- h. Isoceraunic level (days/year) : 50
- i. Seismic level (Horizontal acceleration) : 0.3 g.
- j. General nature of climate : Moderately hot and humid  
tropical climate, conducive to  
rust and fungus growth.

**4.0 REQUIREMENT:** The heat shrinkable / push on type terminations offered shall be of proven design and make, which have already been extensively used and fully type tested.

**5.0 GENERAL REQUIREMENT:** The purpose of this specification is to specify the performance requirements of termination kits for the use on 50 c/s 3 phase system with earthed neutral for working voltage of 11 kV up to 33kV. Earthing arrangement shall be as per relevant standard and details of earthing arrangement offered shall be submitted along with the inspection offer. The material to be used should be inert and capable of resisting degradation during the service of cable system. The kit shall be provided with protection against rodents and termite attack.

### 5.1 Heat Shrinkable Type (Terminations) :

The term heat shrinkable refers to extruded or moulded polymeric materials which are cross-linked to develop elastic memory and supplied in expanded or otherwise deformed size / shape, subsequently heated in an un-constrained state to a temperature above the shrink temperature resulting in the material recovering or shrinking to its original shape.



- 5.1.1 Since the sealant or adhesives (to be used for environment sealing) between the heat shrinkable materials and XLPE cables shall be exposed to high electrical stresses, they must be track resistant.
- 5.1.2 The heat shrinkable polymer materials being used for external leakage insulation between the high voltage of conductors and grounds should be weather resistant.
- 5.1.3 All cuts/nicks inadvertently occurred to XLPE insulation must be rendered discharge free by using suitable discharge suppression compound.
- 5.1.4 The heat shrinkable tubing may be either extruded or moulded type.
- 5.1.5 Higher thickness of heat shrinkable sleeves shall be preferable to counter erosion due to pollution.

**5.2 Other Requirements :**

- 5.2.1 Proper stress control, stress grading and non tracking arrangement in the terminations shall be offered by means of proven methods, details of which shall be elaborated in the bid. Detailed sectional view of assemblies shall be submitted along with the bid.
- 5.2.2 The kits offered shall provide the total environment sealing, the details of which shall be offered along with the bid.
- 5.2.3 Provision for effective screening over each core be made and contractors shall categorically conform this aspect in their bid.
- 5.2.4 The material and components not specifically stated in the specification, but which are essential for satisfactory operation of the equipments shall be included without any extra cost.
- 5.2.5 The terminations shall be of good tracking resistant properties and fully reliable earthing system to maintain continuous contact with screening / armouring as the case may be.
- 5.2.6 The armourearthing arrangement shall form part of the termination.
- 5.2.7 Terminations shall have provision for shield connections and earthing.
- 5.2.8 The kits shall be suitable for storage without deterioration at a temperature up to 50oC for more than 5 years.
- 5.2.9 The fault level (as well as duration) withstand capability of terminations should be strictly matching with these parameters of cables for which the kits are intended to be used.
- 5.2.10 The words 'TSECL' along with trade name of manufacturer, month/year of manufacturer, size etc. shall be embossed/engraved or suitably marked with indelible ink/paint for the purpose of identification.
- 5.2.11 Suitable creepage extension/rain protection sheds for outdoor termination shall be provided.
- 5.2.12 The adequate provisions for eliminating the chances of entrapment of air at the steps formed by semicon screen shall be made.
- 5.2.13 The gripping tubing (termination boot) for the cable where trifurcation takes place, shall also be part of kit and covered under scope of supply of this specification.
- 5.2.14 Name of sub-supplier for the raw material and standard according to which their raw material are tested, must be furnished along with the bid.
- 5.2.15 Detailed kit contents, whether manufactured by the contractor or bought from outside (with name of sub Contractor) for each component must be indicated in the bid.



- 5.2.16 The terminations shall be supplied in kit forms. All insulating and sealing materials, consumable items, conductor fittings, earthing arrangements and lugs etc. shall be included in the individual kit.
- 5.2.17 An instruction manual in English indicating the complete method/procedure to be adopted for installation of kits, preferably with more and more diagrams/pictorial presentation shall be supplied with each kit. Various items/ quantity thereof against each kit must be indicated in the instruction manual.

## 6.0 GUARANTEED TECHNICAL PARTICULARS:

The terminations shall have same electrical and thermal characteristics as those of cables with which these are intended to be used. The bidders must furnish the guaranteed technical particulars for each type/size of kit in Annexure-‘C’.

7. **DRAWINGS:** Complete detailed dimensional drawings showing all details of kit contents/bill of material for each size type.

## 8.0 TESTS :-

- 8.1 **Type tests:** The termination kits offered shall be fully type tested as per the standards certified by an accredited laboratory

### 8.2 Acceptance Tests:

Initially the following tests shall constitute as acceptance tests :-

- i) Dimensional checking as per approved drawings.
- ii) Volume resistivity test for various components.
- iii) AC High voltage test after installation of terminations (as per IS : 13573/1992 or VDE-0278) on appropriate cable.
- iv) Dielectric strength of major components.
- v) D.C. High voltage test.
- vi) Tracking resistance.
- vii) Ultimate elongation.

The scope to include more type tests as acceptance tests shall be decided after processing the offers of various contractors/after knowing the details of testing facilities for type tests available with various bids

### 8.3 ROUTINE TESTS :-The following tests shall constitute routine test :

- i) Dielectric strength.
- ii) Density.
- iii) Heat shock.
- iv) Shrinkage ratio.



The contractor must specify the details of routine tests (being conducted at their works ) along with the standard applicable, in their offer. The routine test certificates shall be furnished along with the inspection call for each offered lot.

#### **9.0 INSPECTION:**

- 9.1 All test and inspection shall be made at the place of manufacture unless otherwise especially agreed upon by the manufacturer and purchaser at the time of purchase. The manufacturer shall afford the inspector representing the purchaser all reasonable facilities without charge to satisfy him that the material is being furnished in accordance with specification.
- 9.2 The purchaser reserves the right to have the test carried at the cost of the supplier by an independent agency whenever there is dispute regarding the quality of supply.

**10.0 PACKING AND TRANSPORT:** The supplier shall be responsible for suitable packing of all the kits of material and marking on the consignment, so as to avoid any damage during transport and storage and to ensure correct dispatch to the destination.

#### **11.0 GUARANTEED TECHNICAL PARTICULARS:**

##### **Guaranteed technical particulars for OUTDOOR / INDOOR**

1. Manufacturer's name & Address.
2. Sr. No. & name and country of origin.
3. Voltage grade.
4. Type of kit offered.
5. Applicable standards.
6. Size.
7. Material of tubing/moulded part/self amalgamating tape etc.
8. Insulation time.
9. Curing time.
10. Time required for energization after completion of termination.
11. Special devices required, if any.
12. Kit storage temperature (Degree centigrade).
13. (a) Shelf life of kit.  
(b) Design life of kit.
14. List of contents of kit (to be furnished separately)
15. Material used for stress control.
16. Dielectric strength of insulation material (kV/mm).
17. Materials used in encapsulating compound and environmental sealing.
18. Class of kit.
19. Whether test reports, drawings and instruction leaf lets are enclosed.
20. Volume resistivity.
  - i) Stress control tubing.



- ii) Non tracking tubing.
- 21. Relative permittivity.
  - i) Stress control tubing.
  - ii) Non tracking tubing.
- 22. Water absorption.
  - i) Stress control tubing.
  - ii) Non tracking tube.
- 23. Tracking resistance.
  - i) Stress control tube.
  - ii) Non tracking tube.
- 24. Tensile strength.
  - i) Stress control tube.
  - ii) Non tracking tube.
- 25. Ultimate elongation
  - (a) Stress control tube.
  - (b) Non tracking tube.

**Note :**While giving details of technical parameters under Sr. No. 20 to 25 above, the reference of applicable relevant ISS/international standard must be indicated

## **BB. TECHNICAL SPECIFICATIONS OF XLPE CABLE LAYING & TERMINATION WORK.**

- 1. SCOPE-** This chapter covers the requirements for the selection, installation, jointing & Commissioning of power cables as per present scope of work .For details not covered in these Specifications, IS : 1255 - 1983 CODE OF PRACTICE FOR INSTALLATION AND MAINTENANCE OF POWER CABLES. All references to BIS-Specifications and codes are for codes with amendments issued upto date i.e. till the date of call of tender.
- 2. STORAGE AND HANDLING**
  - I. The cable drums shall be stored on a well drained, hard surface, so that the drums do not sink in the ground causing rot and damage to the cable drums. Paved surface is preferred, particularly for long term storage.
  - II. The drums shall always be stored on their flanges, and not on their flat sides.
  - III. Both ends of the cables should be properly sealed to prevent ingress/ absorption of moisture by the insulation during storage.
  - IV. Protection from rain and sun is preferable for long term storage for all types of cables. There should also ventilation between cable drums.
  - V. During storage, periodical rolling of drums once in, say, 3 months through 90 degrees shall be done,
  - VI. Damaged battens of drums etc. should be replaced as may be necessary.
  - VII. When the cable drums have to be moved over short distances, they should be rolled in the direction of the arrow marked on the drum.



- VIII. For manual transportation over long distances, the drum should be mounted on cable drum wheels, strong enough to carry the weight of the drum and pulled by means of ropes. Alternatively, they may be mounted on a trailer or on a suitable mechanical transport.
- IX. For loading into and unloading from vehicles, a crane or a suitable lifting tackle should be used. Small sized cable drums can also be rolled down carefully on a suitable ramp or rails, for unloading, provided no damage is likely to be caused to the cable or to the drum.

### 3. INSTALLATION

- I. Cables with kinks, straightened kinks or any other apparent defects like defective armouring etc. shall not be installed
- II. Cables shall not be bent sharp to a small radius either while handling or in installation. The minimum safe bending radius for PVC/XLPE (MV) cables shall be 12 times the overall diameter of the cable. The minimum safe bending radius for PILCA/XLPE (HV) cables shall be as permissible in IS:1255-1983 . At joints and terminations, the bending radius of individual cores of a multi core cable of any type shall not be less than 15 times its overall diameter.
- III. The ends of cables, suitable sealing compound/tape shall be used for this purpose, if likely exposed to rain in transit storage. Suitable heat shrinkable caps may also be used for the purpose
- While the shortest practicable route should be preferred, the cable route shall generally follow fixed developments such as roads, foot paths etc. with proper offsets so that future maintenance, identification etc. are rendered easy
- IV. Cable route shall be planned away from drains and near the property, As far as possible; the alignment of the cable route shall be decided after taking into consideration the present and likely future requirements of other services including cables route, possibility of widening of roads/lanes etc
- V. Corrosive soils, ground surrounding sewage effluent etc. shall be avoided As far as possible, the alignment of the cable route shall be decided after taking into consideration the present and likely future requirements of other services including cables route, possibility of widening of roads/lanes etc for the routes.
- VI. Power and communication cables shall as far as possible cross each other at right angles. The horizontal and vertical clearances between them shall not be less than 60cm.
- VII. Way leave for the cable route shall be obtained as necessary, from the appropriate authorities
- VIII. *Route indicators* - Power cable route Indicators should be provided at an interval not exceeding 200 M and also at turning points of the power cable route wherever practicable.
- IX.

### 4. Methods of laying:-

#### (a) Trenching

- I. XLPE cables under the present scope of work will be laid through digging a trench of 500 mm width and 1200 mm depth excluding locations where it is likely to vary on higher side. The trenches shall be excavated in reasonably straight lines. Wherever there is a change in the direction, a suitable curvature shall be adopted complying with the requirements of IS:1255-1983
- II. Where gradients and changes in depth are unavoidable, these shall be gradual.
- III. The bottom of the trench shall be level and free from stones, brick bats etc.
- IV. The excavation should be done by suitable means-manual or mechanical. The excavated soil shall be stacked firmly by the side of the trench such that it may not fall back into the trench.





V. Adequate precautions should be taken not to damage any existing cable(s), pipes or any other such installations in the route during excavation.

**(b) Sand cushioning**

I. Sand cushioning of 600 mm thick to be placed at the bottom of the trench to form a bed for the cables. **When the cables have been laid they shall be inspected and accepted by the Engineer in Charge.** They shall then be covered with second Sand layer which shall be punned around and over the cables to a level of 100mm above the top of the cables. Where more than one horizontal layer of cables is to be laid similar sand bedding shall be provided for each layer.

**( c ) Flat Brick soling**

I. Two layers of First class brick of nominal size 22cmX11.4cmX7 cm **over the second sand layer to be placed centrally over the cables, throughout the length of the cable.** The bricks to be placed breadth-wise for the full length of the cable. No final filling in of trenches shall be commenced until the Engineer in charge has accepted the placing of Plain Flat Brick soling.

II. Where more than one cable is to be laid in the same trench, this protective covering shall cover all the cables and project at least 5cm over the sides of the end cables.

**(d) Back filling with excavated earth :-** The trenches to be then back-filled with excavated earth, free from stones or other sharp ended debris and shall be rammed and watered, in successive layers not exceeding 30cm depth. A crown of earth not less than 50mm and not exceeding 100mm in the centre and tapering towards the sides of the trench shall be left to allow for subsidence. The crown of the earth however, should not exceed 10 Cms so as not to be a hazard to vehicular traffic. The temporary re-statements of roadways should be inspected at regular intervals, particularly during wet weather and settlements should be made good by further filling as may be required.

- **Extra loop cable:-** Approximately 3m of surplus cable shall be left on each terminal end of the cable and on each side of the underground joints. The surplus cable shall be left in the form of a loop. Where there are long runs of cables such loose cable may be left at suitable intervals as specified by the Engineer-in-Charge.
- **Trenching, laying & sand cushioning work related to coiling of excess Cable and Cable Joints to be provided with same technical specification as detailed above.**

**(e) Testing before laying**

- I. All the time of issue of cables for laying, the cables shall be tested for continuity and insulation resistance \
- II. The cable drum shall be properly mounted on jacks, or on a cable wheel at a suitable location, making sure that the spindle, jack etc. are strong enough to carry the weight of the drum without failure, and that the spindle is horizontal in the bearings so as to prevent the drum creeping to one side while rotating.
- III. The cable shall be pulled over on rollers in the trench steadily and uniformly without any jerks and strain. The entire cable length shall as far as possible be laid off in one stretch. PVC/XLPE cables less than 120sq.mm. size may be removed by “Flaking” i.e. by making one long loop in the reverse direction.
- IV. After the cable has been so uncoiled, it shall be lifted slightly over the rollers beginning



from one and by helpers standing about 10m apart and drawn straight. The cable shall then be lifted off the rollers and laid in a reasonably straight line.

**(f) Testing before covering**

The cables shall be tested for continuity of cores and insulation resistance and the cable length shall be measured, before closing the trench. The cable end shall be sealed /covered.

**(g) Laying of single core cables**

- I. Three single core cables forming one three phase circuit shall normally be laid in close trefoil formation and shall be bound together at intervals of approximately 1m.
- II. The relative position of the three cables shall be changed at each joint at the time of original installation, complete transposition being effected in every three consecutive cable lengths.
- III. Route *indicators* - Power cable route Indicators should be provided at an interval not exceeding 200 M and also at turning points of the power cable route wherever practicable.

**(h) Earthing and Bonding**

- I. The metal sheath, metal screen (if any) and armour of any cable should be efficiently earthed at both ends.
- II. In case of single-core cables of larger sizes, the armour, lead sheath and metal screen, if any, is bonded at times only at one point.
- III. Attention is drawn in this case to the presence of standing voltages along armour or lead sheath and to the considerable increase in such voltages when cables carry fault currents, These voltages must be taken into account when considering safety and outer sheath insulation requirement,
- IV. All metal pipes or conduits in which the cables have been installed, should be efficiently bonded and earthed.

Where cables not having metallic sheath are used, embedding additional earth electrodes and connecting the same with steel armour of cable becomes necessary, Earthing and bonding should be done In accordance with IS : 3043-1966

**(i) High Voltage Test:-** Cables after jointing and terminating are subjected to DC high voltage test as detailed below. The leakage current shall also be measured and recorded for future reference.

DC Test Voltages after Installation (Before Commissioning)			
Rated Voltage of Cables(KV)	Test Voltage between		Duration (in Minutes)
	Any Conductor and Mettalic Sheath / Screen / Armour (in KV)	Conductor to Conductor (for Un Screened Cables(in KV)	
<b>0.65 / 1.1</b>	<b>3</b>	<b>3</b>	<b>5</b>

During the high voltage test, all other electrical equipment related to the cable installation, such as switches, instrument transformers, bus bars, etc, must be earthed and adequate clearance should be maintained from the other equipment and framework to prevent flashovers. In each test, the metallic sheath/screen/armour should be connected, to earth.

**(j) CABLE INSTALLATION PLAN:-** On completion of laying, terminating and jointing of the cables, a plan should be prepared, which should contain the following details of the installation.

- I. Type of cables, cross-section area, rated voltage. Details of construction, cable number and



- drum number;
- II. Year and month of laying;
- III. Actual length between joint-to-joint or ends;
- IV. Location of cables and joints in relation to certain fixed reference points, for example, buildings, hydrant, boundary stones, etc;
- V. Date of making joint; and
- VI. Results of original electrical measurements and testing on cable installation.
- VII. Cables shall be properly arranged in the trenches such that criss crossing is avoided and final take off to feeder pillars / poles or as required as specified or as per approved drawing is facilitated. Contractors are responsible for arrangement of cables in cable trench. Adequate sizes of GI pipe sleeves shall be utilized for end termination of cable. Pipe sleeves shall be laid at an angle of maximum 45° to the trench wall. In case of larger dia cables i.e. 50 mm and above adequately sized pipe with larger bend radius shall be provided for ease of drawing of cable or for replacement. In place where it is not possible, a smaller trench may be provided as approved by Engineer in charge.
- VIII. Cable markers shall be provided as directed at every 30 m and at cable joint locations.**
- IX. Temporary ends if any shall be protected against dirt and moisture and prevents damage to the insulation. Proper PVC or rubber insulating tape shall be used. Use of friction type or fabric tape is not permitted
- X. Cables laid underground in excavated cable trenches shall be as per the approved drawings. Trenches shall be of sufficient depth and width for laying of all cables. Cables shall be spaced properly so that heat dissipation is attained..
- XI. Cables shall be laid in trenches as shown in the drawing. Before laying the cable the bottom of trench shall be filled with sand 150 mm of depth duly leveled. The cables laid on this sand shall be covered with further 150 mm depth sand on top of largest diameter of the cable. Sand shall be lightly pressed. Protective covering of suitable bricks / HT tiles/ half round slab as specified and as per approved drawings shall be provided before back filling the trench with soil, rammed and leveled.
- XII. Insulation resistance test of all the cables shall be taken in presence of Engineer in charge. Defective cables shall be immediately replaced before laying of cables of other groups.
- XIII. Suitable GI / HDPE/ RCC hume pipes for protection as directed shall be provided as required. Cable ends shall be drawing carefully through such pipes to prevent damage to the cable. Radius at bending shall not be less than the recommended bending radius of the cables specified by the manufacturer. Standard gauge of pipe filling shall be used for sizing the pipe.
- XIV. Prior approvals for cutting holes for laying cable in existing structures and foundations shall be obtained from the Engineer in charge.
- XV. GI pipes laid for cable laying shall be bend with hydraulically operated bending machine.(which is to be arranged by the contractor).Bends of pipes shall be placed in such a way that they are concealed in wall, soil or structures. The open end of the pipes shall be suitably plugged with plugs supplied by the contractor at no extra cost.
- XVI. Supporting angles for cables shall be suitably clamped / tied by means of nylon cords and the angles shall be painted before laying the cables. The paint shall be done with one coat of red lead paint and two coats of approved bituminous aluminum paint unless



otherwise specified.

## **Z1. TECHNICAL SPECIFICATION FOR THE L.T AERIAL BUNCHED CABLES.**

### **1.0 SCOPE:**

- 1.1 This specification covers the design, manufacture, testing, inspection, packing, transportation and delivery of Cross linked polyethylene (XLPE) insulated Aluminium Cables twisted over a central aluminium alloy insulated messenger wire (along with associated accessories) for use on LT overhead distribution feeders, supply of required accessories and installations. The cable should be suitable for use on three-phase AC (Earthed) system for rated voltage up to and including 1100 Volts and UV protected. 1.2 The cables should be suitable for use where the combination of ambient temperature and temperature rise due to load, including temperature exposure to direct sunlight results in conductor temperature not exceeding the following:

**Table: 1**

<b>Type of Insulation</b>	<b>Normal continuous Operation</b>	<b>Short circuit Operation</b>
Cross linked polyethylene	90° C	250° C

### **2.0 APPLICABLE STANDARDS:**

The following standards with latest updates shall be applicable unless otherwise specified:

- a. IS:14255-1995 Aerial Bunched cable for working voltage up to and including 1100 Volts.
- b. IS:10810 (Series) – Methods of testing cables.
- c. IS : 8130 – 1984 for Aluminium conductors for insulated electric cables.
- d. IS : 398 (Part-IV) 1994 : For all Aluminium Alloy Conductors (AAC) for overhead transmission purposes.-PART 4 Aluminium alloy stranded Conductors (aluminium–magnesium-silicon type).
- e. IS:1885 (Part32) – Electro technical vocabulary:Part32 Electric Cables. f. IS: 6474 for insulation.

### **2.1 LT Aerial Bunched Cables:**

#### **Electrical Data:**

- a. The rated voltage of the cables shall be 1.1kV.
- b. Highest system voltage: 1.2 kV.
- c. Test Voltage: i) 2.5 kV / 50 Hz/ 5 min for routine tests. ii) 4 kV / 50 Hz/ 4 Hrs. for type tests.
- d. Max. short circuit current 1.0 kA for 1 Sec..
- e. Current carrying capacity at different ambient air temperatures of different sizes of phase conductors are tabulated at Table - 2.

**THE CURRENT RATING AND SHORT CIRCUIT CAPACITY SHALL BE AS GIVEN BELOW:**



Table – 2

Nominal sectional area (mm <sup>2</sup> )	Current rating at 40°C (approx) Amps XLPE	Short Circuit capacity KA/1Sec.
16	74	1.50
25	100	2.35
35	125	3.29
50	150	4.70
70	186	6.58
95	230	8.93

### 3.0 GENERAL :

The insulated phase conductors shall be twisted around the insulated aluminium alloy messenger wire, which shall take all the mechanical stress. The messenger wire shall also serve as the earth-cum-neutral wire and shall be insulated.

#### 3.1. CONDUCTORS :

- 3.1.1 The phase conductor shall be of Aluminium round, stranded and compacted aluminium wires conforming to H2 or H4 grade aluminium complying with requirements of IS:8130, the nominal cross sections and corresponding conductor diameter and number of wires etc., shall be as per clause 3.1.8 of this specification.
- 3.1.2 The phase and neutral conductors shall be insulated with black weather resistant Cross linked polyethylene insulation by extrusion process and suitable for 1100V insulation. The insulated conductors shall generally conform to the relevant IS standards as noted in clause 2.0 above. The thickness of insulation shall not exceed the limits specified in clause No.7.2, Table 4 and tolerance shall be as per clause No. 7.3 of IS:14255.
- 3.1.3 The power / outer –insulated neutral / street lighting conductors shall conform to flexibility class 2 of IS 8130. The messenger cum neutral conductor or otherwise shall either be stranded circular or compacted circular type and shall have minimum of 7 strands. The surface of the conductor shall be smooth.
- 3.1.4 The messenger cum neutral conductor shall be heat treated aluminium magnesium – silicon alloy wires containing approx 0.5% magnesium and 0.5% silicon conforming to IS 398 Part-4 with latest revision thereof.
- 3.1.5 A protective barrier shall be applied between conductor and insulation. The barrier shall be compatible with insulating material and suitable for operating temperature of the cable.
- 3.1.6 The size of the street lighting conductor shall be 16sqmm.

#### 3.1.7 DIMENSIONAL AND ELECTRICAL DATA.

- 3.1.8 The dimensional and electrical data for the cable and street lighting conductor shall be as given in Table 3, below. The resistance values are the maximum permissible.

Table 3:

Nominal sectional area (mm <sup>2</sup> )	No of strands	Dia. Of compacted conductor (mm)	Approx. mass (Kg/km)	Max. DC resistance at 20C/KM	Insulation Thickness (mm)
(1)	(2)	(3)	(4)	(5)	(6)



16	6	4.4	42	1.91	1.2
25	6	5.5	65	1.20	1.2
35	6	6.8	95	0.868	1.2
50	6	7.9	127	0.641	1.5
70	12	9.6	184	0.443	1.5
95	15	11.3	254	0.320	1.5
120	15	12.9	315	0.253	1.5

**Note: a). The Resistance value given in col. 5 are max. permissible.**  
**b). Tolerance of + 5% is allowable on diameter shown in col.3**

**3.1.9 Phase Identification :**

Durable and clearly visible longitudinal ridges shall be provided as follows on each insulated conductors as indicated below for identification of phases.

For phase conductors (3 Core Cable) = R, Y, B

For Street Light Conductor = SL

For Neutral/Messenger Conductor = N

Approx. ridge dimensions are:

- Width = 1.00 mm
  - Height = 0.4 mm
  - Distance between = 2.7 mm.
- consecutive ridges

**4.0 INSULATED MESSENGER (NEUTRAL CONDUCTOR) :**

**4.1.1** The messenger shall be an All Aluminium Alloy conductor composed of 7 Wires each of nominal dia 3.55 mm Dia drawn from rod, which is manufactured in a continuous casting and rolling procedure. The properties for the individual wires before stranding shall be.

- Tensile strength not less than 294 N/mm<sup>2</sup>
- Elongation on 200 mm not less than 4%.
- Resistivity at 20 Deg. C not exceeding 0.0328 ohm Sq.mm/m
- Density at 20 Deg. C 2.7 Kg/cubic – dm

**4.1.2** No joints are allowed in the messenger except those made on the base rod or wire before final drawing. The messenger shall be round, stranded and compacted to have smooth round surface.

**4.1.3** The messenger takes all the mechanical stress and also serves as neutral conductor. The size and requirement of messenger conductor for minimum DC resistance and minimum breaking load shall be as per clause No.6.5 and Table 4 of IS: 14255.

**Table-4**

Sl. No.	Nominal Cross Sectional Area of	Messenger Conductor		
		Nominal Cross	Maximum DC	Minimum



	<b>Phase Conductor mm<sup>2</sup></b>	<b>Sectional Area mm</b>	<b>Resistance at 20° C ohm/km</b>	<b>Breaking Load kN</b>
1	16	25	1.38	7.0
2	25	25	1.38	7.0
3	35	25	1.38	7.0
4	50	35	0.986	9.8
5	70	50	0.689	14.0
6	95	70	0.492	19.7





**Note:** While the limiting values in Col. 4 & 5 are to be guaranteed, a tolerance of +5% will be permissible on values in Col.2.

### 5.0 DESIGN:

- 5.1.1 The cable consists of three phase aluminium conductors and one street light aluminium conductor with black weather resistant special high density Cross linked polyethylene insulation, shall be twisted around a insulated all aluminium alloy messenger which is also the neutral conductor without fillers with lay not exceeding 35 times the diameter of the insulated phase conductor.
- 5.1.2 The thickness at any place may be less than the specified average value, provided that the difference does not exceed 0.1 mm + 0.1(ti) of the specified average value in clause No.7.2, Table 5 and tolerance shall be as per clause No. 7.3 of IS:14255.
- 5.1.3. The insulation shall be applied that fits closely on the conductor (or barrier, if any) and it shall be possible to remove it without damaging the conductor. Further, for the thickness of insulation, six measurements are made radially on a piece of insulation, as far as possible equally spaced around the circumference but not on the ridges.
- 5.1.4. The insulation shall be black weather resistant suitable for 1100V and confirming to IS:6474.
- 5.1.5. The properties of XLPE insulation shall confirm to clause No. 5.1, Table 1 and 2 of IS: 14255.
- 5.1.6. The insulation shall be XLPE of nominal thickness and its properties shall confirm to IS: 7098 & IS: 6474. The black carbon content in XLPE shall be 2% only

### 6.0. Designation and parameters of the Finished Cables:

The designation and parameters of the finished cables shall be as given in the Table 5 below. The first part of the designation refers to the Number & size (cross sectional area in sq.mm) of the Phase Conductor, the second part refers to the (cross sectional area in sq.mm) of the Messenger.

**Table: 5: Sizes**

Description of Sizes	Complete Cable	Bunched
	Approx. Overall dia. (mm)	Approx. Cable mass (Kg/Km)
3x16+1x16+1x25	19	310
3x25+1x16+1x25	22	390
3x35+1x16+1x25	24	490
3x50+1x16+1x35	32	640
3x70+1x16+1x50	34	890
3x95+1x16+1x70	39	1180
3x95+1x25+1x70	41	1260
3x95+1x35+1x70	43	1360
3x120+1x16+1x95	42	1430

### 8.0 TYPE TESTS ON LT AB CABLE:

Unless otherwise stated in this specification, the type tests and routine/acceptance tests shall be carried out in accordance with the appropriate clauses of IS:14255 and IS:10810.



**9.0 TYPE TESTS AS PER CL.10.1 AND 11.4 OF IS:14255/1995 :**

- a) Tests on phase/street light conductor
  - i) Tensile Test
  - ii) Wrapping Test
  - iii) Resistance Test
- b) Tests on messenger conductor
  - i) Breaking Load
  - ii) Elongation Test
  - iii) Resistance Test
- c) Physical test for XLPE Insulation:
  - i) Tensile strength and elongation at break
  - ii) Ageing in Air oven
  - iii) Hot set test
  - iv) Shrinkage test
  - v) Water absorption (Gravimetric)
  - vi) Carbon black:
    - content
    - dispersion
- d) Test for thickness of insulation
- e) Insulation resistance (volume resistivity)
- f) High voltage test
- g) Bending test on complete cable
- h) Ultra violet test on cable to withstand ultra violet radiation.

**1.1 ACCEPTABLE as per Cl.10.2 of IS: 14255/1995 :**

- a. Tensile tests for phase/street light conductor.
- b. Wrapping Test for phase/street light conductor.
- c. Breaking load test for messenger conductor.
- d. Elongation test for messenger conductor.
- e. Conductor resistance test.
- f. Test for thickness of insulation.
- g. Tensile strength and elongation at break
- h. Hot set Test for XLPE Insulation.
- i. Insulation resistance test.
- j. High voltage test k. High Voltage Test on DRUM, immersed in water & apply test voltage 3.5kV AC for 5 min.
- l. Weather ability test for withstanding weather conditions.
- m. Adherence test on insulated messenger wire

**1.2 ROUTINE TESTS as per Cl.10.3 of IS: 14255/1995:**

- a. Conductor Resistance Test.
- b. High Voltage Test

**1.3 OPTIONAL TEST:** This test to be insisted as part of Acceptance tests during inspection.

**Bending Test on the Complete Cable :**

The test shall be performed on a sample of complete cable. The sample shall be bent around a test mandrel at room temperature for at least one complete turn. It shall then be unwound and the process shall be repeated after turning the sample around its axis 180 Deg. The



cycle of these operations shall then be repeated more. The diameter of the mandrel shall be  $10(D + d)$ .

Where  $D$  = actual diameter of the cable (i.e., minimum circumscribing circle diameter in mm)  $d$  = actual diameter of the conductor in mm. No cracks visible to the naked eye are allowed.

**Type Test Report:**

The bidder shall submit type test reports for the particular sizes asked in the tender for the type tests carried out from NABL accredited Laboratory and the reports should not be older than 5 years as on the date of opening of tender. The bid not carrying valid type test reports will not be considered for evaluation.

**1.4 SAMPLING OF CABLES:**

In any consignment the cables of the same size manufactured under essentially similar conditions of production shall be grouped together to constitute a lot. Samples shall be taken and tested from each lot for ascertaining the conformity of the lot to the requirement of the specification. The number of drums( $n$ ) to be selected from the lot of drums( $N$ ) of consignment of cables shall be in accordance with column 2 and 1 of following table:

**Table 6:** Number of Drums to be selected Sampling and permissible Number of Defectives.

Number of Drums in the Lot (1) $N$	Number of Drums to be Taken as Sample (2) $n$	Permissible Number of Defectives (3) $a$
Upto 50	2	0
51 to 100	5	0
101 to 300	13	0
301 to 500	20	1
501 and above	32	2

The sample shall be taken at random. In order to ensure randomness of selection, random number table shall be used as per IS 4905.

Number of tests and criteria for conformity: Suitable length of test sample shall be taken from each of the drums selected. The test sample shall be subjected each of the acceptance test. A test sample is defective if it fails in any of the acceptance test. If the number of defectives is less than or equal to the corresponding permissible defective( $a$ ) given in the table 9 the lot shall be declared as conforming to the requirements of acceptance test, or otherwise not.

**9.0. PACKING AND MARKING :**

The Cable shall be wound on non-returnable wooden drums conforming to IS: 10418 /1982 with latest amendment thereof. The ends of the cable shall be sealed by means of nonhygroscopic sealing materials. The drum shall be marked with the following.

- a. Manufacturer's Name or Trade Mark.
- b. Type of cable and voltage grade.
- c. Drum number or identification number.



- d. Number of cores and size of cable.
- e. Number and length of pieces of cable in each drum.
- f. Gross / Net mass of the cable.
- g. Direction of rotation of drum. (By means of an arrow).

**9.1** The drums shall be of such construction as to assure delivery of conductor in the field free from displacement and damaged and should be able to withstand all stresses due to handling and the stringing operation so that cable surface is not dented, scratched or damaged in any way during transport and erection. The cable shall be properly lagged on the drums. The cable drum shall be suitable for wheel mounting.

**9.2** The min. drum length of cable shall be 500 mtrs, the tolerance  $\pm 5\%$ .

### **9.3 MARKING OF CABLE:**

All the cables shall have the following marking embossed on the insulated phase conductors for identification: letters BESCOM; Ref P.O & Date in addition to manufacturer's name or trade mark year of manufacture at regular intervals of not more than one meter. The cables with cross linked polyethylene insulation shall be identified throughout the length of the cable by the legend 'XLPE 90'.

### **10.0 QUALITY ASSURANCE PLAN**

10.1 The successful bidder shall submit following information to the owner.

10.2 Test certificates of the raw materials and bought out accessories.

10.3 Statement giving list of important raw materials, their grades along with names of sub-suppliers for raw materials, list of standards according to which the raw materials are tested. List of tests normally carried out on raw materials in presence of bidder's representative.

10.4 List of manufacturing facilities available

10.5 Level of automation achieved and lists of areas where manual processing exists.

10.6 List of areas in manufacturing process, where stage inspections are normally carried out for quality control and details of such tests and inspection.

10.7 List of testing equipments available with the bidder for final testing of equipment along with valid calibration reports.

10.8 The manufacture shall submit manufacturing quality plan (MPQ) for approval & the same shall be followed during manufacture and testing.

10.9 The successful bidder shall submit the routine test certificates of bought out raw material/accessories and central excise passes for raw material at the time of inspection.

### **11.0 GUARANTEE:**

The supplier of AB Cable shall guarantee overall satisfactory performance for minimum period of 5 years.

11.1 At least three copies of latest type test reports shall be furnished. One copy shall be returned duly certified by the owner, only after which the commercial production of the concerned material shall start.

11.2 Copies of acceptance test reports shall be furnished in at least five sets (each set for GM, TA&QC/Procurement/P&M). One copy shall be returned duly certified by the owner, only after which the materials shall be dispatched.

11.3 Record of routine/internal test reports shall be maintained by the supplier at his works for periodic inspection by the owner's representative.



11.4 Test certificates of test during manufacture shall be maintained by the supplier. These shall be produced for verification as and when desired by the owner.

## 12.0 INSPECTION:

- 12.1 The owner's representative shall at all times be entitled to have access to the works and all places of manufacture, where AB Cables and its component parts shall be manufactured and the representatives shall have full facilities for unrestricted inspection of the supplier's and sub-supplier's works, raw materials, manufacture of the material and for conducting necessary test as detailed herein.
- 12.2 The material for final inspection shall be offered by the supplier only under packed condition. The owner shall select samples at random from the packed lot for carrying out acceptance tests. The lot offered for inspection shall be homogenous and shall contain AB Cables manufactured in 3-4 consecutive weeks.
- 12.3 The supplier shall keep the owner informed in advance of the time of starting and the progress of manufacture of material in their various stages so that arrangements could be made for inspection.
- 12.4 No material shall be dispatched from its point of manufacture before it has been satisfactory inspected and tested unless the inspection is waived off by the owner in writing. In the later case also the material shall be dispatched only after satisfactory testing specified here in has been completed.
- 12.5 The acceptance of any quantity of material shall in no way relieve the supplier of his responsibility for meeting all the requirements of the specifications and shall not prevent subsequent rejection, if such materials are later found to be defective.
- 12.6 The prospective bidders should furnish the GTP of AB Cables as per Annexure-1.

## 13.0 GUARANTEED TECHNICAL PARTICULARS FOR LT. AERIAL BUNCHED CABLE

### Annexure - 1

Sl. No.	Particulars	Cable Size xxxxx
1	<b>Name of manufacturer.</b>	
2	<b>Applicable standard/specification.</b>	
<b>3</b>	<b>Type of Cable</b> (construction to be described)	
<b>4</b>	<b>Size of Cable.</b>	
<b>5</b>	<b>Phase Conductor - A1u Portion.</b>	
	i) Material of conductor.	
	ii) Applicable standard.	
	iii) No. of strands.	
	iv) Nominal diameter of strand (mm).	
	v) Max. diameter of bare conductor (mm)	
	vi) Nominal area of cross-section of bare conductor (Sq.mm)	
	vii) Lay ratio.	
	ix) Elongation at break (%)	
	x) Tensile strength (min)/breaking load (KN)	
<b>5A</b>	<b>Phase conductor – Insulation portion.</b>	
	i) Material of insulation.	



	ii) Insulation thickness (mm)	
	iii) Diameter of insulated conductor (mm)	
	iv) Whether the insulation conforms to the standards specified in the technical specification	
<b>6</b>	<b>Street Light Conductor-Alum. Portion</b>	
	i) Material of Conductor	
	ii) Applicable Standard	
	iii) No. of Strands	
	iv) No. Diameter of the strand in mm.	
	v) Max. diameter of bare conductor	
<b>6A</b>	<b>Street Light Conductor-Insulation Portion</b>	
	i) Material of Insulation	
	ii) Insulation Thickness (mm)	
	iii) Diameter of insulated conductor (mm)	
	iv) Whether the insulation conforms to the standards specified in the technical specification	
<b>7</b>	<b>Messenger/neutral conductor - AAA portion.</b>	
	i) Material of conductor.	
	ii) Applicable standard	
	iii) Number of strands	
	iv) Nominal diameter of strand (mm).	
	v) Max. diameter of bare conductor (mm)	
	vi) Nominal area of cross-section of bare conductor (Sq.mm)	
	vii) Lay ratio	
	ix) Elongation (%)	
	x) Tensile strength (min)/ breaking load (KN)	
<b>7A</b>	<b>Insulation portion.</b>	
	i) Material of insulation.	
	ii) Insulation thickness (mm)	
	iii) Diameter of insulated conductor (mm)	
	iv) Whether the insulation conforms to the standards specified in the technical specification.	
<b>8</b>	<b>Complete AB Cable</b>	
	i) Overall diameter (mm)	
	ii) Total weight (kg/km)	
	iii) Standard drum length offered (mtrs)and tolerance	
	iv) Gross weight of the cable drum	
	v) Code or method of cable identification.	
<b>9</b>	<b>Electrical Data :</b>	
	i) Max. DC resistance of the phase conductor at 20C	
	ii) Max.DC resistance of the neutral conductor at 20 Deg.C	
	iii) AC resistance at – 90 Deg. C phase conductor (ohms/km)	
	iv) AC resistance at – 90 Deg C messenger/ neutral conductor (ohms/km)	
	v) Max. DC Resistance of the street light conductor at	



	20 Deg. C	
	vi) AC Resistance at 90Deg. C Street light	
	vii) Approx. inductive reactance at 50 Hz. Phase conductor/Street light (ohms/km)	
	viii) Approx. inductive reactance at 50 Hz. Messenger/neutral conductor (ohms/km)	
	ix) Approx. zero sequence reactance at 50 Hz. Per phase (ohms/km):	
	x) Short circuit current for 1 Sec. Max. (KA)	
	xi) current carrying capacity (amps) at various ambient temp.deg. Of 10°C,20 °C ,30 °C ,40 °C & 50 °C	
<b>10</b>	<b>Specification climatic conditions to which AB Cable are manufactured.</b> a) Max. Solar radiation (w/sq.mm) b) Min. wind velocity (m/sec.)	
<b>11</b>	Tests. i) Details of type tests and factory tests conducted on each size of AB Cable . ii) Whether one complete set of type test certificates there of are enclosed to the bid.	
<b>12</b>	<b>BENDING RADIUS OF CABLE :</b>	
<b>13</b>	<b>Any other relevant technical information the bidder may desire to furnish in respect of</b> i) AB Cable.	





## SECTION – VI

### SPECIAL INSTRUCTIONS TO BIDDER(S)

- i) The Bidder(s), before submitting of Bid(s), are advised to invariably visit the site of the work and satisfy himself about physical volume of works to be carried out, acquaint him with the environment, take into consideration details of all **minor & major Technical requirements so as to** ensure successful completion of the work with ease & comfort on award.
- ii) The work is a **Turnkey assignment** in Nature. The Contractor shall be fully responsible for total commissioning of all **Equipment & associated controls** as per standard & requirement of TSECL. Therefore the Contractor shall give due importance to each & every details of the work. He shall be liable to take care of and arrange for even any petty but integral component (**not considered in the scope of the work**) for total completion of the work.
- iii) The Bidder(s) shall have to furnish "**Guaranteed Technical Particulars**" of **each item** of **Equipments / Switchgears / Spares / others** as per "**Technical Particulars**" sought in **FORMAT(s)** appended in the Bidding Document. Furnishing of "**Technical Particulars**" of such item(s), which have not been sought through formal **FORMAT** in the Document, shall be the responsibility of the Bidder(s) as per guaranteed particulars of the related Manufacturer(s).
- iv) The Bidder(s) shall have to furnish Manufacturer's "**Literature on product Specification**" of all **Major equipment** with Bidding Document.
- v) The Bidder(s) shall also furnish "**Technical Particulars**" of all sub-item(s) of Main Item, **for example, "Tri-vector" Energy meter of Control & relay Panel.**
- vi) **List of MAKE for Equipments / Switchgears and all other items** have been furnished in the **Bidding Document**. The Bidder(s) shall have to supply item of such **MAKE acceptable** as **Standard Product** and to be authenticated by supporting Document as to utilization by any State Electricity board / Power utility / Power corporation of the Country.
- vii) The Successful Bidder shall have to submit "Design, drawing and dimensional details" of all equipments, Switchgears, Structures, Construction Standards and **Bill of materials** etc. within 15 days from the date of issue of Letter of Award (LOA) for approval of the Owner. The work shall be based strictly on such approved drawing.
- viii) The Spares and Tools & Plants as specified in the Schedule shall be of the particular MAKE. All such spares and T & P shall be supplied along with related Literature / Manual / Catalogue of concerned Manufacturer.
- ix) Specification of All Civil Works shall be guided by the Standards of TRIPURA PWD (Public Works Department). The Successful Bidder shall have to submit "Design and drawing of Sub-station layout, Foundation of Equipments and Structures, Cable Trench Details, Repair to Boundary Wall and Internal wiring of Control Room Building etc." within 15 days from the date of issue of LOA for approval of the Owner. The work shall be based strictly on such approved drawing.



### **TECHNICAL SPECIFICATIONS**

1. This document shall be read in conjunction with the other tendering Documents.
2. The work shall be carried according to the description of the Item(s) in the Bill of quantities attached in Part – I. The building work shall generally conform to specifications for works in “The Tripura PWD Specification 1972 Building Work” where Tripura PWD specifications for building work is silent, CPWD specifications or provisions contained in “National Building Code” (Latest Edition) shall be followed.
3. “Specification for Road & Bridge Works (Latest Revision)” published by the Ministry of shipping, Road Transport & Highways (MoRTH, Specification for Rural Roads, MoRD) shall be followed, and where the said specification is silent or items which are not covered, the Tripura PWD Specification, 1972/the specification of CPWD/CPHEEO/CWC/BIS or relevant IRC Standard Specifications as amended till date as determined by the Deputy General Manager, in that order should be followed.

4.

### **SPECIAL CONDITION**

#### **1. Specification of Cement**

- a) OPC CEMENT OF ISI Marked 43 grade containing 50 Kg each bag, conforming to IS: 8112 only to be used of current manufacturing date not before 90 days to reach in at work site.
  - b) Cement will be of in machine stitched polythene bag of preferable manufacturer (i) Valley Strong (ii) Star (iii) Crown etc.
  - c) Cement is to be purchased from the authorized dealer having Tripura sale tax registration. Prior to procurement approval from authority to be obtained. Cement shall be brought at site in bulk supply as desires by the Engineer-in-charge.
  - d) Before use of cement in the work, the original cash memo /voucher is to be produced before the Sr.Manager / Manager. The Sr.Manager should maintained a cement register separately in respect of procuring cement by the contractor.
2. Specification of steel reinforcement arranged by the agency shall confirm to relevant IS codes / BIS codes procured from TATA ISCON (TMTSD) / SAILTMT (EQR) / SRMB TMT / ELEGANT TMT.
  3. Necessary test certificate from Government recognized lab from cement ,steel, concrete, sand, bricks etc. shall have to be produced by the contractor as an when asked by the TSECL at agency's cost . Test certificate shall be confirm to the relevant IS as well as BIS codes.
  4. Stone aggregate (Assam Stone) must be of well graded machine crushed matching with the relevant specification and IS code of the work. Necessary T.P of carriage up to works side to be submitted to TSECL. Documentary proof (T.P) issued by the concerned authority (forest Department) to be furnished prior to execution.
  5. Before submitting the tender , the tenderer's are to satisfied themselves by actual visit to site, regarding availability of the labour and materials and site condition and any claim of the tenderer submitting tenders shall not be entertained afterword in respect of non-availability of labour, materials and site conditions . Any roads and paths, if required for the work will have to be made by the contractor at his own cost and nothing extra will be paid.
  6. During the period, prior to the handing over of the work complete in all respects to the Deputy General Manager, damarages to the work, if any, is to be made good by the contractor at his own cost and noting extra will be paid.



7. Concrete mixture machine, Vibrator to be used for any kind of C.C and R.C.C work (Full bag 10/7 capacity Mixture machine with hopper).
8. Weight machine to be kept at work site to verify the weight / mass of the material contained.
9. Sand shall be of relevant IS code preferably from Chechrimile quarry.
10. Traffic on the road should be maintained if required during working period and the contractor will have to take precaution for his workers. If necessary, he will have to provide diversion at his own cost.
11. The contractor shall be responsible for the true and perfect setting out of the work and correctness of the position, level, and dimensions of all parts of the work. If at any time during the progress of the work shall any error arise in the position, level, or dimensions of any part of the work, fitting or fixing etc. the contractor shall be liable to rectify or change as directed by the Deputy General Manager at his own cost and risk.
12. The work, which does not conform to specification, must be struck down and rejected materials removed from the site of works as directed by the Deputy General Manager.
13. Contractor must take arrangement to dump disposable / excavated earth outside the project periphery at his own cost and risk. No charge / payment in this regard will be entertained. No plea about dumping of earth will be tenable.
14. The Department / Corporation will not take any responsibility regarding any permit. Contractor shall arrange permit if required at his risk and cost for collecting any materials from outside Tripura state. They are requested to get themselves apprised of GST rules.
15. Only ply shuttering to be used (Mix 12mm thick) in this work for all R.C.C. Unserviceable / defective ply / form box will not be allowed in, any case.
16. Green ply / kitply to be used as flash door shutter.
17. All PVC pipes, fittings must be made of prince / oriplast.
18. Vitrified tiles, or other glazed tiles must be made of Kazaria, Johnson, Vermora, make.
19. C.P bibcock, stopcock, pillar tape, basin tape must be made of Royal / Pushp / Mare Jaquan make. Heavy GI fittings to be used for internal water supply net work including conceel line if any. All sanitary fitting like European commode, Indian OT pan, Urinal pan etc. must be made of Hind ware / Pary ware make.
20. Door locks, latches, handles, door closures etc. must be made at Gadrej / link.



**Annexure – I**

**PRICE BREAK-UP FOR SUPPLY: -**

- |  |     |            |
|--|-----|------------|
| a) Basic price   | : - | Rs.        |
| b) Road Transport charges, including Loading at dispatch point, unloading inclusive of comprehensive insurance and other charges | : - | Rs.        |
| c) <b>Total</b>  | : - | <b>Rs.</b> |
| d) GST rate  | : - |            |
| e) GST amount  | : - | Rs.        |
| f) Discount if any on Rs.....  | : - | Rs.        |
| g) Bidder should declare any other Taxes / duties not covered above and Amount, if applicable                                    | : - | Rs.        |
| h) <b>Grand total</b>  | : - | <b>Rs.</b> |

**PRICE BREAK-UP FOR CIVIL & ERECTION WORK: -**

- |   |     |     |
|---|-----|-----|
| a) Basic price  | : - | Rs. |
| b) GST rate   | : - |     |
| c) GST amount   | : - | Rs. |
| d) Discount if any on Rs.....   | : - | Rs. |
| e) Bidder should declare any other Taxes / duties not covered above and Amount, if applicable | : - | Rs. |
| f) <b>Grand total</b>   | : - |     |

**Signature of the Tenderer / Bidder**



**Annexure – VI**

**MAKERS LIST OF MATERIALS**

Sl. No.	Items	Manufacturer
1.	Power Transformer	BHEL / ALSTOM / CGL / Siemens / Bharat Bijlee / ABB / Transformers & Rectifiers (India) Ltd./ Volt Amp / Prolec GE.
2.	132 KV SF <sub>6</sub> Breaker	Alstom / CGL / Siemens / ABB / BHEL
3.	33 KV SF <sub>6</sub> Breaker	CGL / ABB / Schneider
4.	132 KV Isolator	Siemens / ABB / CGL / Alstom / Hivelm / M/s Raychem RPG Pvt. Ltd., / GR Power / Project Electricals (PEI)
5.	33 KV Isolator	Switchgear & Control Pvt. Ltd. / JK Electricals / Bharat Electrical Industries / Hivelm / Project Electricals (PEI) / Siemens / GR Power / Electrolities (Power) Pvt. Ltd.
6.	132 KV CT	Alstom / CGL / Siemens / ABB / Vidyut Control System Pvt. Ltd.
7.	33 KV CT	Vidyut Control System Pvt. Ltd. / Switchgear & Control Pvt. Ltd. / Schneider / CGL / ABB
8.	132 KV PT	Alstom / CGL / Siemens / ABB
9.	33 KV PT	Vidyut Control System Pvt. Ltd. / Switchgear & Control Pvt. Ltd. / Schneider / CGL / ABB
10.	LA	Alstom / CGL / Oblum / Raychem RPG / Lamco Ltd.
11.	CVT	Alstom / CGL / BHEL / ABB / Siemens
12.	Hardware Fittings / Clamps, Connectors etc	EMI / Rashtraudyog Ltd. / Electromech&Transtech / EMC LTD / IAC / Klemmen / Megha / IPS / TLP / TM POWER.
13.	Power cable	Havells / Polycab / KEI / Gloster / Torrent / GEMSCAB / CCI
14.	Control Cable	Havells / Polycab / KEI / Gloster / Torrent / GEMSCAB / CCI
15.	Relay & Control Panel	Siemens / ABB / ALSTOM / L & T / Schneider Electric / PASCAL SWITCHGEAR / AMARARAJA
16.	Nuts & Bolts and other hardwares	Reputed manufacturer having credentials of supplying to different Central / State power utilities.
17.	Relays	SIEMENS / ABB / GE ALSTOM
18.	11 KV VCB	Crompton Greaves / Siemens / ABB / L & T / PASCAL
19.	Energy Meter	L & T (ER 300P)
20.	Battery & Battery Charger	Exide / Amara Raja / Chabbi Electricals Pvt. Ltd. / Caldyne
21.	Oil Filter Plant	John Fowler (NIRMAL BRAND) / CEE DEE Vacuum / AR ENGINEERING.
23.	Sub-Station Lighting Equipments	Philips / Havells / CGL / Bajaj.
24.	Marshaling Kiosk / box, Junction box.	Electro Allied Products / VikasEngg. Associates / Bose Corporation / Control & Switchgear / Maktel.



<b>Sl. No.</b>	<b>Items</b>	<b>Manufacturer</b>
25.	Structural Steel	Re-rollers shall purchase Billets from SAIL / TISCO / RINL / ISCO / VIZAG / Other reputed manufacturer having credentials of supplying to different Central / State power utilities.
26.	Nuts & bolts and other hardwares	Reputed manufacturer having credentials of supplying to different Central / State power utilities.
27.	ACSR PANTHER conductor of size 30/7/3.0 mm	APAR Industries / Saravathi Conductor / Sterlite Industries / Smita Conductor / Cabcon India Pvt. Ltd./ Lumino Industries Ltd / Reputed manufacturer having credentials of supplying to different Central / State power utilities.
28.	7/3.15 mm galvanized Steel Stranded Wire of Gr. – III conforming to ISS: 2141 of 1979 of as amended latest	Reputed manufacturer having credentials of supplying to different Central / State power utilities.
29.	Hardware fittings	EMI / Rashtraudyog Ltd. / Electromech&Transtech / EMC LTD / IAC / Klemmen / Megha / IPS / TLP
30.	Disc Insulator (11 KV Disc Insulator of size 255 mm X 145 mm Ball & Socket type EMS 120 KN)	Aditya Birla Insulators Ltd. / BHEL / IEC / WSI / Reputed manufacturer having credentials of supplying to different Central / State power utilities.
31.	40 mm dia G.I. Pipe	TATA / BANSAL / BMW / JINDAL.

All materials should be embossed/engraved with **TSECL-IPDS** for identification.



ANNEXURE-I

**PROFORMA OF BANK GUARANTEE FOR  
CONTRACT PERFORMANCE  
(To be stamped in accordance with stamp Act)**

Ref. .... Bank Guarantee No. ....

Date .....

To  
Tripura State Electricity Corporation Limited  
BidyutBhavan, North Banamalipur,  
Agartala – 799001,  
West Tripura.

Dear Sir,

In consideration of **Tripura State Electricity Corporation Limited** (hereinafter referred to as the 'Owner', which expression shall unless repugnant to the context or meaning thereof include its successors, administrators and assigns) having awarded to M/s ..... with its registered / Head office at .....(hereinafter referred to as 'Contractor' which expression shall unless repugnant to the context or meaning thereof, include its successors, administrators, executors and assigns), a Contract by issued of Owner's Letter of Award No.....dated.....and the same having been acknowledged by the Contractor, resulting in a Contract bearing No. ....dated .....valued at .....for .....(scope of contract) and the Contractor having agreed to provide a Contract Performance Guarantee for the faithful performance of the entire Contract equivalent to .....being .(%) per cent) of the said value of the Contract to the Owner.

We, ..... (Name & Address) having its Head Office at.....(hereinafter referred to as the 'Bank', which expression shall, unless repugnant to the context or meaning thereof, include its successors, administrators , executors and assigns) do hereby guarantee and undertake to pay the Owner, on demand any or all monies payable by the Contractor to the extent of .....as aforesaid at any time up to ..... \*\* (see in note below) ..... (days/month/year) without any demur, reservation, contest, recourse or protest and/or without any reference to the Contractor.

Any such demand made by the Owner on the bank shall be conclusive and binding notwithstanding any difference between the Owner and the Contractor or any dispute pending before any Court, Tribunal, Arbitrator or any other authority. The Bank undertakes not to revoke this guarantee during its currency without previous consent of the Owner and further agrees that the guarantee herein contained shall continue to be enforceable till the Owner discharges this guarantee.

The Owner shall have the fullest liberty without affecting in any way the liability of the Bank under the guarantee, from time to time to extend the time for performance or the Contract by the Contractor. The Owner shall have the fullest liberty, without affecting this guarantee, to postpone from time to time the exercise of any powers vested in them or of any right which they might have against the Contractor, and to exercise the same at any time in any manner, and either to enforce or to for bear to enforce any covenants, contained or implied, in the Contact between the Owner and the Contractor or any other course or remedy or security available to the Owner. The Bank shall not be released to its obligations under these presents by any exercise by the Owner of its liberty with reference to the matters aforesaid or any of them or by reason of any other act of omission or commission on the part of the Owner or any other indulgences shown by the Owner or by any





other matter or thing what so ever which under law would, but for this provision have the effect of relieving the Bank.

The bank also agrees that the Owner at its option shall be entitled to enforce this guarantee against the Bank as a principal debtor, in the first instance without proceeding against the Contractor and not withstanding any security or other guarantee the Owner may have in relation to the Contactor's liabilities.

Notwithstanding anything contained herein above our liability under this guarantee is restricted to .....and it shall remain in force upto and including .....and shall be extended from time to time for such period (not exceeding one year), as may be desired M/s .....on whose behalf this guarantee has been given.

Dated this ..... day of .....200..... At .....

**WITNESS**

.....

(Signature)

(Signature)

.....

(Name)

.....

(Name)

.....

(Official Address)

.....

(Official Address)

Attorney as per Power  
Of Attorney No. ....

Date .....

**NOTES:**

- This sum shall be 'ten per cent (10 %)' of the Contact Price.

**\*\*The date will be ninety (90) days after the end of date of 'Warranty Period' as specified in the Contract.**

**1.The Stamp Papers of appropriate value shall be purchased in the name of issuing Bank.**

\*\*\*\*\*



**ANNEXURE-II**

**APPLICATION FOR EXTENSION OF TIME**

(Part – I)

1. Name of Contractor \_\_\_\_\_
2. Name of work (as given in the contract) \_\_\_\_\_  
\_\_\_\_\_
3. Agreement no. \_\_\_\_\_
4. Contract amount \_\_\_\_\_
5. Date of Commencement of work as per agreement \_\_\_\_\_
6. Period allowed for completion of work (as per agreement) \_\_\_\_\_
7. Date of completion stipulated in the agreement \_\_\_\_\_
8. Actual date of completion \_\_\_\_\_
9. Period for which extension of time has been given previously if any \_\_\_\_\_
- a) 1<sup>st</sup> extension vide No. \_\_\_\_\_
- b) 2<sup>nd</sup> extension vide No. \_\_\_\_\_
- c) 3<sup>rd</sup> extension vide No. \_\_\_\_\_
- d) 4<sup>th</sup> extension vide No. \_\_\_\_\_
10. Period for which extension have been previously given (Copies of the previous application should be attached).
11. Hindrances on account of which extension is applied for with date on which hindrances occurred.

Sl. No.	Nature of hindrances	Date of occurrence	Period of which hindrances is likely to last	Extension of time applied for by the contractor	Overlapping period, if any, giving reference to items which overlap	Period for which extension is applied for.	Remarks as to why the hindrances occurred and justification for extension of time

12. Total period for which extension is now applied for on account of hindrances mentioned above.
13. Extension of time required for extra work: - \_\_\_\_\_ Months. \_\_\_\_\_ days.
14. Detailed for extra work and the amount involved: -
15.
  - a) Total value of extra work: -
  - b) Proportionate period of extension of time based on estimated amount put to tender on account of extra work: -
16. Total extension of time required for 11 & 12: -

**Signature of Contractor**



**APPLICATION FOR EXTENSION OF TIME**

(Part – II)

(To be filled in by TSECL)

1. Date of receipt of application from \_\_\_\_\_ contractor for  
the work of \_\_\_\_\_  
\_\_\_\_\_ in the Sub-  
Divisional \_\_\_\_\_.
  
2. Acknowledgement issued by the Sr. Manager, vide his No. \_\_\_\_\_  
\_\_\_\_\_ Dated \_\_\_\_\_.
  
3. Recommendation of Sr. Manager, in – charge of the Sub-Division is to whether the reasons given by the Contractor are correct and what extension, if any, recommended by him, if he does not recommended the extension, reasons for rejection should be given

Dated .....	Signature of the Sr. Manager in-charge of Sub-Division.
-------------	---



**APPLICATION FOR EXTENSION OF TIME**

(Part – III)

(To be filled in by TSECL)

1. Date of receipt in the Divisional office: \_\_\_\_\_
2. Report of DGM, in-charge of the Division regarding hindrances mentioned by the contractor  
\_\_\_\_\_

Sl. No.	Nature of hindrances	Date of occurrence	Period for which hindrances is likely to last	Extension of time applied for by the contractor	Overlapping period, if any, giving reference to items which overlap	Net extension applied for	Remarks as to why the hindrances occurred and justification for extension recommended

3. Recommendation / Approval of the DGM, in-charge of the Division: -  
(The present progress of work should be stated and whether the work is likely to be completed by the date upto which extension is applied for, if extension of time is not recommended, what compensation is proposed to be levied under clause 13 of section - III.

**Signature of DGM**

4. Recommendation / Approval of the AGM, in-charge of the Circle: -

**Signature of AGM**

5. Recommendation / Approval of the GM (Technical): -

**Signature of GM (Technical)**

6. Recommendation / Approval of the CMD: -

**Signature of CMD**



**ANNEXURE – III**

**DECLARATION BY BIDDER**

I/We hereby declare that I/we have personally gone through the Bid-Document of Contract, Technical Specifications, other instructions/ Special instructions etc. incorporated in the Bidding Document for the works/ Supply and I/We do agree to abide by all the rules and regulations of TSECL, Agartala, Tripura.

Date:-

Place:-

Authorized signatory  
of Firm/Agency

SEAL





**Annexure-V**

ACCEPTANCE LETTER AFTER DUE ATTESTION BY NOTARY  
(TO BE SUBMITTED IN TECHNICAL BID)

Refer NIT No. \_\_\_\_\_ Date \_\_\_\_\_

To  
The Deputy General Manager Project  
Tripura State Electricity Corporation Limited  
Bidyut Bhavan  
Banamalipur,  
Agartala, West Tripura

Sir,

Acceptance of TSECL'S NIT Clause No. 7.7(v) of Section –I

1. I/We hereby declare that I/We have gone through the NIT Clause No. 7.7(V) of Section –I of this NIT.
2. I/We hereby declare the acceptance of the aforesaid mentioned clause.
3. I/We hereby on behalf of (the name of the Vendor/Firm.....) declare that we are not "De-barred/Black listed" by any Central (GOI)/State Govt owned Power Utility, for supply of similar materials during last 3 years for whatever reasons.

Date:.....

(Signature of the Tenderer)

Yours faithfully,

With rubber Stamp

Attestation Signature of Notary  
With Rubber Stamp

Date:





**Annexure-VI**

**Bidder's Financial Capabilities**

<b>The Details may be submitted in the following format</b>	
Bidder's Legal Name	: _____
Date	: _____

<b>Information from Balance Sheet</b>					
Sr. No.	Particulars	FY 2018-19 (Amount in INR)	FY 2019-20 (Amount in INR)	FY2020-21 (Amount in INR)	Enclose Documents
1	Total Assets				
2	Total Liabilities				
3	Net Worth (1-2)				
<b>Information from Profit &amp; Loss Statement</b>					
7	Total Turnover (in INR)				
8	Average Turnover for 3 years				
<p>Note:</p> <p>Attached are copies of financial statement (Balance Sheet including all related notes, and income statements) for the years required above, complying with the following conditions:</p> <ul style="list-style-type: none"> <li>All such documents reflect the financial information of the bidder and not sister or parent companies</li> <li>Historic financial statement must be audited by the Statutory Auditor</li> <li>Historic financial statement must be complete, including notes to the financial statement.</li> <li>Historic financial statement must correspond to accounting periods already completed and audited (no statement for partial period shall be requested or accepted)</li> </ul>					
Seal & Sign of Statutory Auditor or Chartered Accountant					
Name of the Audit Firm:					
Firm Reg. Number.					
Date:					
(Signature, name and designation of the authorised signatory)					



## Section-VII

### Price Schedule/BoQ

Price shall be submitted/uploaded as per Price Schedule/BoQ given/uploaded in the **e-procurement portal** <http://tripuratenders.gov.in>